

# Installation Guide

## Ancon Masonry Support System

Ancon Masonry Support Systems are designed to support external masonry façades above openings and at horizontal movement joints. They are generally fixed to concrete or steel frames and adjustment is provided in every direction to allow for tolerance in the structural frame.

### Important Notes

Masonry support systems form an important part of the final structure of a framed building and it is essential that the correct installation procedures are followed. This not only applies to the installation of the support system itself, but also to the building of the masonry supported by the system and the installation of the wall ties.

Care should be taken to avoid damaging the masonry support system prior to and during installation. All components should be stored under cover and away from direct sources of heat.



Ancon stainless steel products are produced from laser-cut plate. As with all industrial fabrications these may present sharp edges. Suitable personal protective equipment should be worn at all times during handling and installation.

### Installation of Ancon Masonry Support Systems

Ancon Masonry Support Systems must be installed in accordance with this guidance. If in doubt contact us.

The masonry support system must be positioned at the correct level; there must be no gaps between the back of the bracket / angle and the structure at both the fixing point and the lowest point of contact between the system and the structure. Where shims are used between the bracket / angle and the structure they should be flat and the thickness limited to the outside diameter of the fixing, unless otherwise agreed with us. The fixing bolts must be tightened to the correct torque using a calibrated torque wrench.

### Setting the Support System at the Correct Level

It is usual for the support system to be set at least 2mm high; this is to allow for bedding in, deflection of the support system and movements associated with the fixing and shimming.

The mortar bed above the angle should be limited to a maximum thickness of 5mm. Where pistol (recessed) bricks are used which have a deep cut-out, the angle will need to be set higher to limit the mortar bed to a maximum of 5mm.

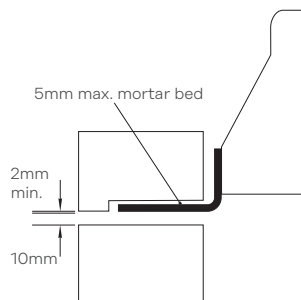

In some cases it may be necessary to make an additional allowance for movement of the structure, especially when the structure is a steel frame.

### Cavity Variation

- 1 An increase in cavity width is accommodated by inserting full height stainless steel shims between the structural face and the back of the masonry support system. The maximum allowable shim thickness for a given project is stated on our layout drawings. Shims can be included between the bracket and the frame up to a maximum thickness of 12mm. In exceptional circumstances, increased shimming can be accommodated, only after consultation with our technical staff.

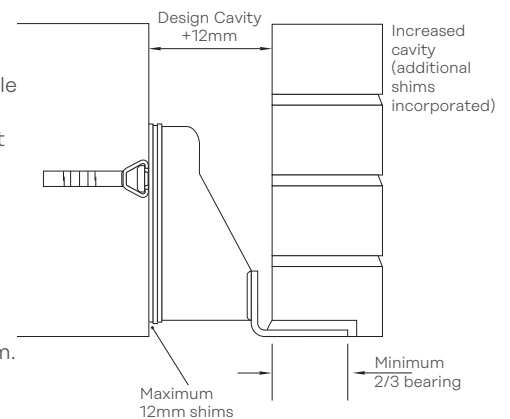

#### Increased cavity



When utilising shims, they must be of sufficient length to extend to the lowest point of contact between the bracket / angle and the structure.

- 2 A decrease in cavity width is overcome by re-positioning the brick on the support angle; this increases the amount of actual support under the brick. This operation may necessitate cutting the brick to clear the angle radius. Design criteria govern the extent of allowable movement.

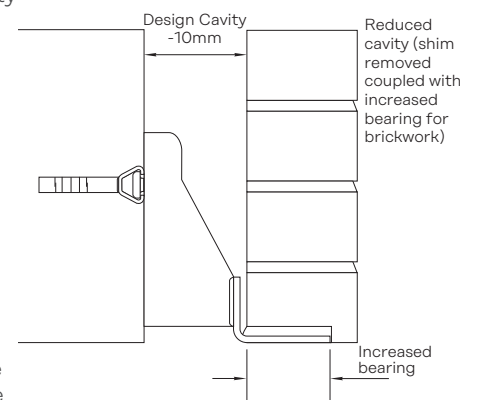

#### Reduced cavity

# Installation Guide

## Ancon Masonry Support Systems

### Vertical Adjustment

Vertical adjustment is achieved with vertical serrated slots in the support system. Ancon Support Systems are designed to accommodate adjustment of  $\pm 20\text{mm}$ . The slot depth accommodates the vertical adjustment of Ancon Steelgrip bolts with an outside diameter of 19mm. Fixings with a smaller diameter should not be installed to the top or bottom of the slot. It is important to utilise the fixings supplied as these are an integral component of the design. Serrated washers must be installed in the correct orientation i.e. serrations horizontal to match those on the bracket. Ensure nuts are tightened to the tightening torque specified on the drawings (see our Bolt Fixings Installation Guide for further information).

### T-Head Bolts Inserted into Channel and Turned Through 90°

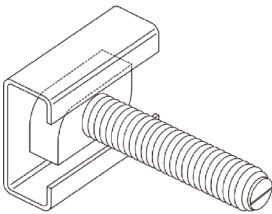

Insert T-Bolt with line horizontal

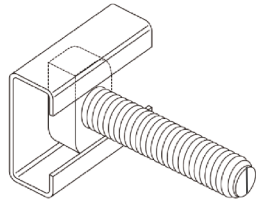

Twist 90 degrees and ensure T-bolt is locked in place with line vertical

### Horizontal Adjustment

Continuous support systems are designed with a 10mm nominal gap between individual units. This provides a degree of tolerance to accommodate variation in the structure and thermal expansion of the masonry support angles. Where required, these gaps can be reduced to a minimum of 5mm or increased to a maximum of 20mm - note that any gap increases should be approved by your Leviat design team. Cast-in channel will provide virtually unlimited horizontal adjustment; slotted holes in a steel edge member will offer more limited adjustment.

### Brickwork Bearing

Angles should be set so that a minimum of 2/3 bearing is achieved for the brickwork. There is the potential for brickwork 'bellying' to be induced where 2/3 bearing is not maintained. Refer to project specific drawings supplied by Leviat.

### Bi-Metallic Corrosion

Ancon Support Systems are manufactured from stainless steel. Bi-metallic corrosion may occur in a damp environment where the stainless steel support system is bolted to the structural steel frame. This will not affect the stainless steel, but could slightly increase the corrosion rate of the carbon steel.

When Ancon Masonry Support Systems are fixed back to steel structures, the structural component may be isolated from the stainless steel support system to prevent the possibility of bi-metallic corrosion.

This can be achieved in one of two ways:

- 1 Painting the areas that will be in contact with the support system
- 2 Inserting an isolation shim (as shown below)

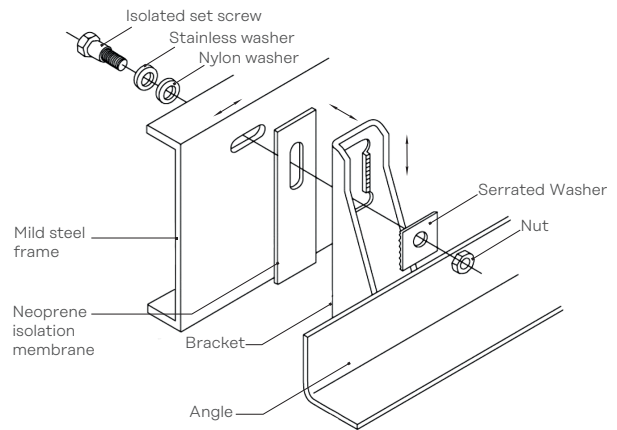

### Thermal Breaks

Ancon Masonry Support Systems can be supplied with Thermal Breaks to minimise cold bridging and improve the energy efficiency of your building project. Shaped like a standard Ancon key-hole shim, these Thermal Breaks have been independently tested and verified as 'A2-s1, d0 reaction-to-fire classification' and have a thermal conductivity of just 0.3W/mK.



Ancon thermal breaks should be treated as a loose shim and therefore must be included when calculating the maximum shim thickness that can be used with a system.

### Building on Masonry Supports

When installing an Ancon Masonry Support System it is important to follow the stages below.

#### 1 Building on First Course of Masonry

The first course of masonry, usually a pistol brick, should be built on a thin bed of mortar on the angle of no more than 5mm thickness. Thick mortar joints under pistol bricks, particularly the three-hole type can allow the brick to rotate especially if the mortar has not had sufficient time to cure. The bottom of the brick should be positioned to allow for the expected deflections. Before any further courses are built, the mortar should be allowed sufficient time to cure. The time period will vary, but should be at least one to two days, and will be more if the mortar has additives to extend its workability and/or in particularly cold weather.



Exercise caution when using bricks with large open volumes. The reduced footprint on the mortar bed may require the first course to be left longer to cure before continuing with the build.

# Installation Guide

## Ancon Masonry Support Systems

### 2 Building of Next Five Courses

Another five courses should be built which will include a DPC course and a line of wall ties above the support level. These ties should be built within 225-350mm above the support angle and at 300-600mm horizontal spacing.

These ties are essential and it is important that they are securely fixed back to a solid structure. It is difficult to assess the precise load in these ties because this will vary depending on the thickness of the support angle, the density of masonry and the height of masonry at any particular time; however it should be no more than 300N per tie. Ancon strip ties with a standard 3-hole "S" end will provide a high factor of safety against failure after two days.



Ensure that the first ties are properly positioned and are securely fixed back to a rigid structure.

### Damp-Proof Course

DPC/cavity tray should be installed according to the manufacturer's recommendations. As soon as possible after laying the DPC, lay at least one further course of masonry, including a full bed of mortar. This will help develop good adhesion between masonry units, mortar and DPC.

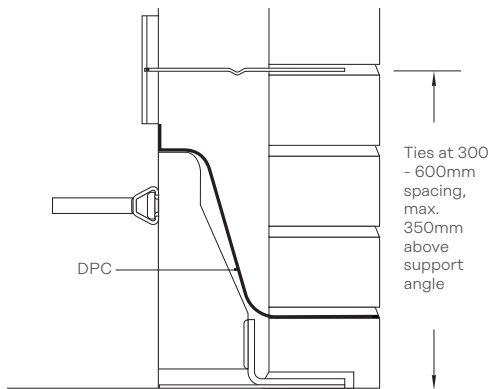

### Summary

- 1 Position masonry support system allowing for minimum 2mm deflection.
- 2 Limit shims to the diameter of fixing or 16mm, whichever is less.
- 3 Tighten fixing to specified torque using a calibrated torque wrench.
- 4 Ensure proper contact between back of bracket and structure.
- 5 Build first line of bricks with 5mm maximum mortar bed.
- 6 Leave at least 1-2 days for mortar to cure.
- 7 Build next 5 courses including DPC and ties at max. 350mm above support level and at 300 - 600mm horizontal spacing.
- 8 Leave another 1-2 days for mortar to cure.
- 9 Continue building up to 1500mm height a day incorporating ties at maximum 600mm horizontal spacing and 600mm vertical spacing (unless closer spacings are specified). The ties should be evenly distributed over the wall area, except around openings, and should preferably be staggered.

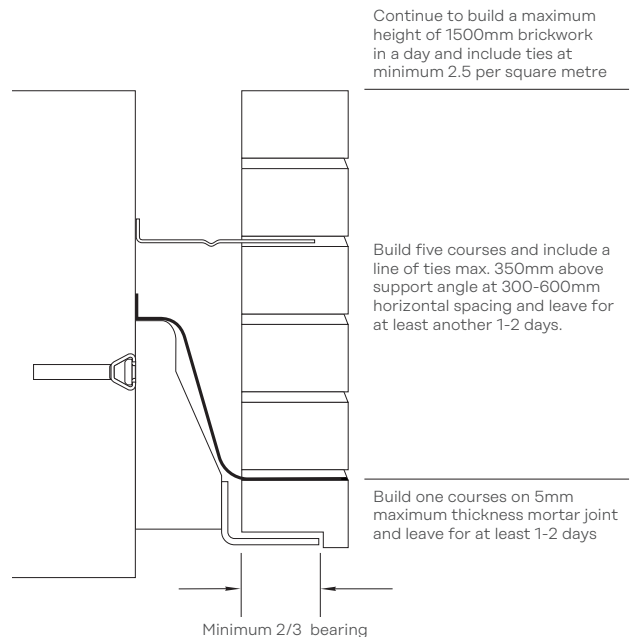

Before any further courses are built, the mortar should be allowed sufficient time to cure for the ties to take the restraining load as the brickwork proceeds. The time period will vary, but should be at least two days, and will be more if the mortar has additives to extend its workability and/or in particularly cold weather.