

Leviat®

Australian Edition

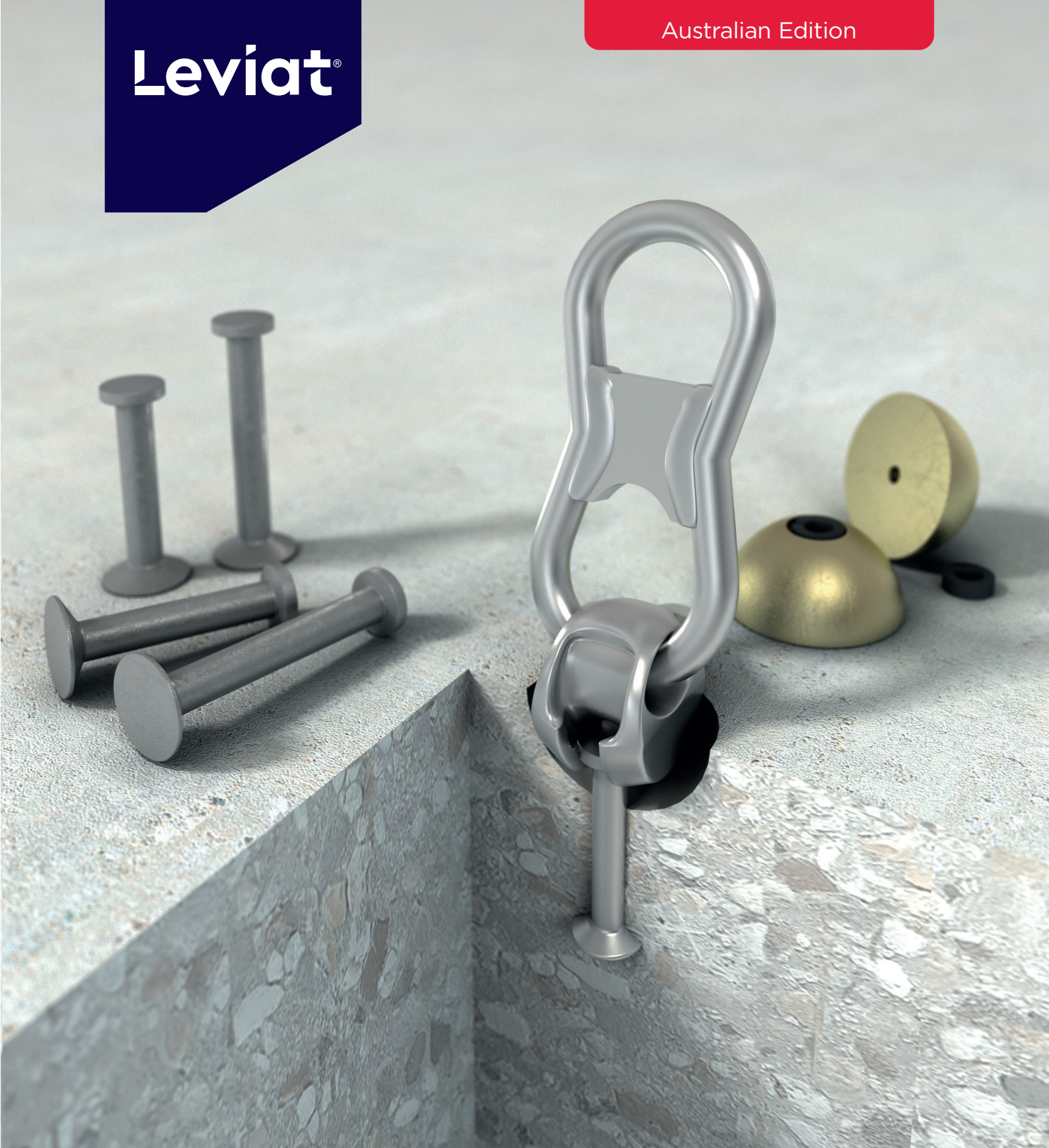

COMPLIANT
AS 3850.1:2015



April 2023

Ancon®

**Ancon Unilift and
Ancon EdjPro Clutch
Discard Criteria**

Leviat

We imagine, model and make engineered products and innovative construction solutions that help turn architectural visions into reality and enable our construction partners to build better, safer, stronger and faster.

Leviat is a world leader in connecting, fixing, lifting and anchoring technology.

From the build of new schools, hospitals, homes and infrastructure, to the repair and maintenance of heritage structures, our engineering skills are making a difference around the world.

We provide technical design assistance at every stage of a project, from initial planning to installation and beyond.

Our technical support services range from simple product selection through to the development of a fully customised project-specific design solution.

Every promise we make locally, has the commitment and dedication of our global team behind it. We employ almost 3,000 people at 60 locations across North America, Europe and Asia-Pacific, providing an agile and responsive service worldwide.





>3,000
People

60+
Locations

~20
Countries

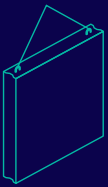

Lifting & Bracing

Systems for the safe and efficient transportation, lifting and temporary bracing of cast concrete elements and tilt-up panels before permanent structural connections are made.

- Precast Lifting
- Tiltup Lifting
- Bracing & Anchorage

Other areas of expertise:

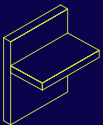

Structural Connections

Systems to form robust, efficient connections, and continuity of concrete reinforcement as necessary, between walls, slabs, columns, beams and balconies, providing structural integrity as well as enhanced thermal and acoustic performance.



Façade Support & Restraint

Systems for the safe and thermally-efficient fixing of the external building envelope, including brick and natural stone, insulated sandwich panels, curtain walling and suspended concrete façades, and also the repair and strengthening of existing masonry installations.

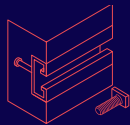

Anchoring & Fixing

Systems for fixing secondary fixtures to concrete, including anchor channels, bolts and inserts; also tension rod systems for roofs and canopies.



Formwork & Site Accessories

Non-structural accessories that complement our engineered solutions and help keep your construction environment operating safely and efficiently, including moulds for casting standard and special concrete elements and construction essentials such as reinforcing bar spacers.

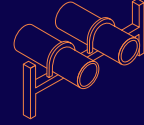

Industrial Technology

Mounting channels, pipe clamps and other versatile framing systems that provide safe fixing in a wide range of industrial applications.

Leviat product ranges:

Ancon | Aschwanden | Connolly | Halfen | Helifix | Isedio | Meadow Burke | Modersohn | Moment | Plaka | Scaldex | Thermomass

Ancon Unilift Locking Klaw Discard Criteria

Discard Criteria for Spherical Headed (SH) Anchor Systems

The following diagrams show the causes for immediate discard/replacement.

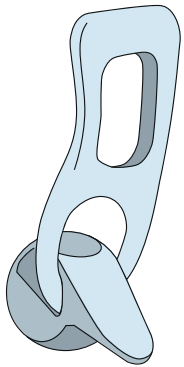

Bent or distorted handle

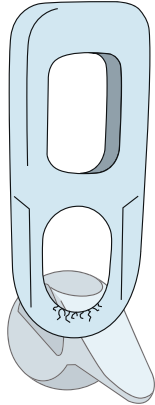

Excessive loop wear and deformation

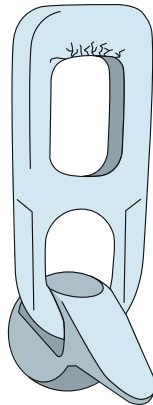

Excessive deformation with cracking in the handle

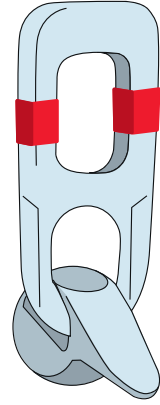

Unauthorised repair or modification e.g. welding

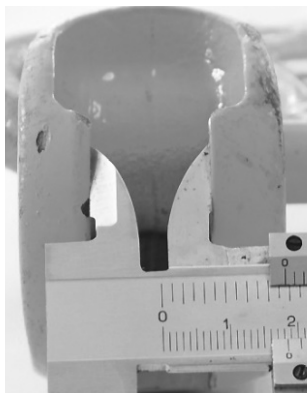

Out of tolerance slot

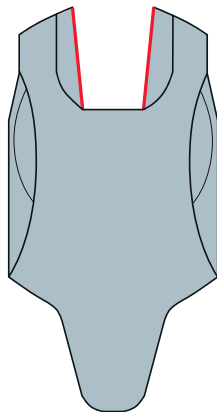

Bent lips, slot too wide

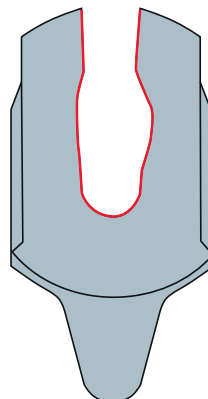

Bending, distortion of the loaded slot lips



Bent, worn slot

Immediate Discard Criteria for Ancon Unilift Locking Klaws

According to AS 3850.1: 2015, each clutch should be load tested to 1.2 x WLL at least annually.

Clutches should be immediately withdrawn from service and scrapped if:

- The Ancon Unilift Locking Klaw visibly deforms or fails during a proof load test.
- There is a defect or wear which could reduce the safe working capacity of the clutch.

Cracking

If there are any visible cracks in any part of the Locking Klaw, it should be discarded immediately.

Deformation

During the annual inspection the width of the slot and the width of the lip thickness should be measured.

The following table shows the threshold values.

Working Load Limit	Max slot width (mm)	Min lip thickness (mm)
1.3	13	5.5
2.5	18	6
5	25	8
10	32	12
20	46	18
32	58	24

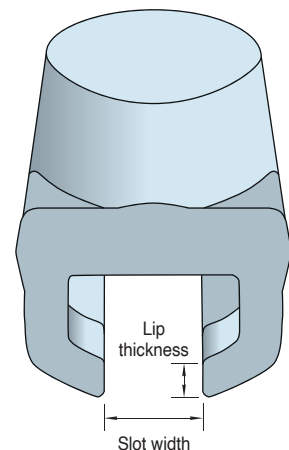

Discard Criteria for Ring Clutch (RC) Anchor Systems

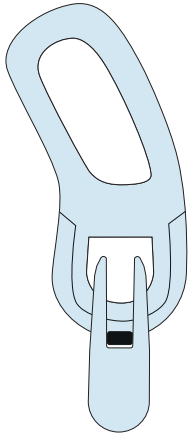

Distorted handle

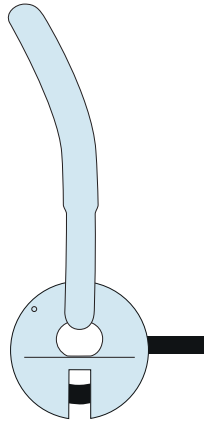

Bent handle

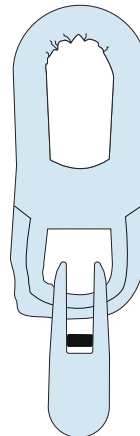

Distortion or excessive wear and/or cracking of upper or lower loops

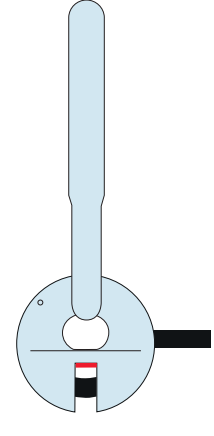

Wear, distortion in the "bridge" of the slot



Broken locking rings



Bent, distorted locking rings

Ancon EdjPro Clutch Discard Criteria

Ancon EdjPro Clutch Discard Criteria

This discard criteria applies to Ancon EdjPro clutch models manufactured from 2020, shown below.



Note: Discard criteria for superseded clutch models are available from Leviat upon request.

General criteria for immediate discard and replacement: damage, distortion or fracture

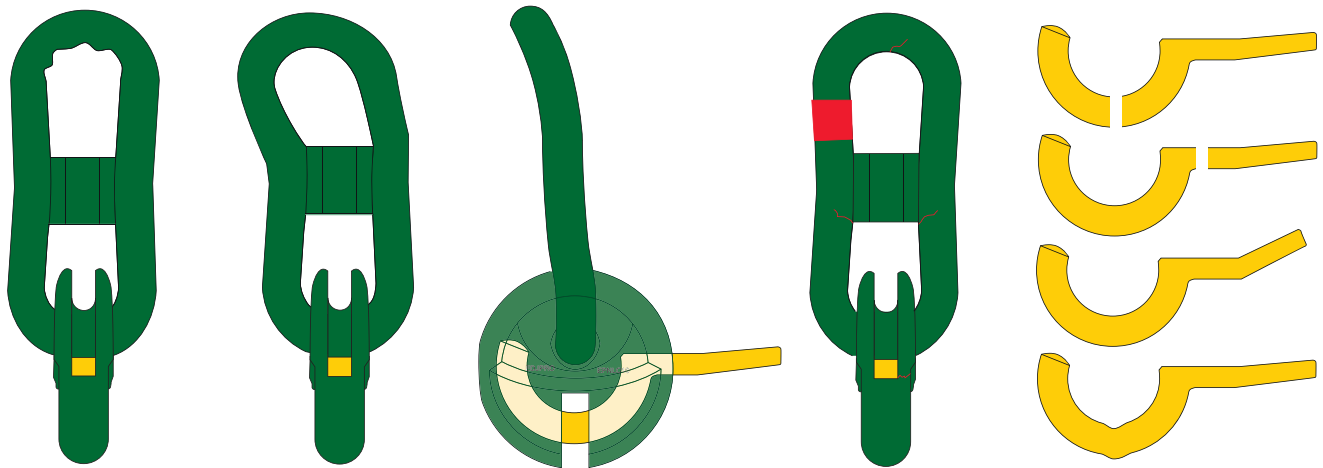

Severe wear, excessive bruising

Distortion

Bending

Evidence of weld repairs or cracking

Locking ring fracture, bending, distortion, wear

Any clutch which shows evidence of cracking, overloading or distortion more than 5 degrees out of plane from the original shape or dimension should be immediately withdrawn from service, destroyed and replaced with a genuine Ancon EdjPro clutch.

Ancon EdjPro clutches are not compatible with, and may not be substituted by, clutches made by others.

Discard Dimensions and Proof Test Load Requirements

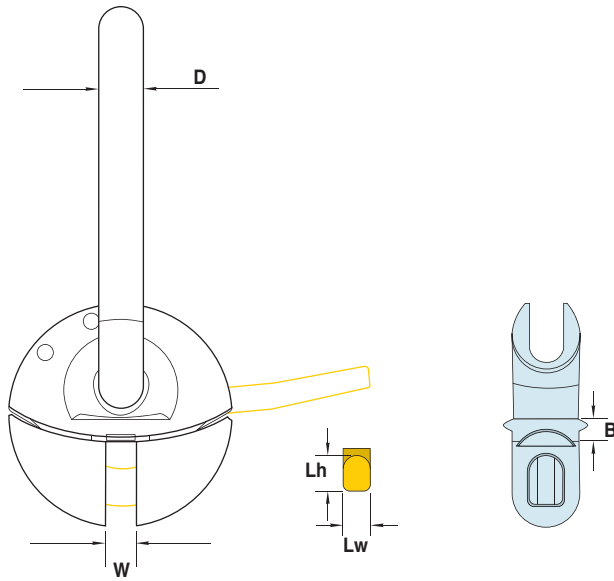

Ancon EdjPro Clutch	Loop and Handle Diameter	Slot Width	Bridge Depth	Locking Ring Width	Locking Ring Height	WLL	Annual Proof Test Load
Dimension after wear	Average (minimum diameter)	Maximum	Minimum	Minimum	Minimum		
	D mm	W mm	B mm	Lw mm	Lh mm	tonnes	kN
EPLCMax	25	23	14	14.5	21	15	177
EPLCMini	17	20	6.5	12	15.5	8.5	100
EPLC04	14	19	8	12	12	4	47

Notes: Each clutch is tested to twice the WLL prior to first sale. This initial test always leaves a small “dent” inside the top loop and some wear and bruising caused by the attached lifting tackle is normal. The average diameter shown above should be made by taking at least 5 measurements around the circumference.

At least annually, each clutch must be visually inspected for wear, damage and distortion and proof tested to the load shown in the table above, by a third party accredited test authority in accordance with the requirements of AS 3850.1:2015.

A compatible Ancon EdjPro anchor or a test piece approved by Leviat shall be used for the proof test.

The clutch must attain the proof load without signs of distortion or failure. Failure to meet the proof load shall be a reason for immediate clutch destruction and replacement.

Contact Leviat worldwide

Australia

Unit A, 1 Heinrich Close,
Eastern Creek, Sydney, NSW 2766
Tel: +61 - 2 8808 3100
Email: info.au@leviat.com

Austria

Leonard-Bernstein-Str. 10 Saturn
Tower, 1220 Wien
Tel: +43 - 1 - 259 6770
Email: info.at@leviat.com

Belgium

Industrielaan 2
1740 Ternat
Tel: +32 - 2 - 582 29 45
Email: info.be@leviat.com

China

Room 601 Tower D,
Vantone Centre
No. A6 Chao Yang Men Wai Street
Chaoyang District
Beijing P.R. China 100020
Tel: +86 - 10 5907 3200
Email: info.cn@leviat.com

Czech Republic

Business Center Šafránková
Šafránková 1238/1
155 00 Praha 5
Tel: +420 - 311 - 690 060
Email: info.cz@leviat.com

Finland

Vädursgatan 5
412 50 Göteborg / Sweden
Tel: +358 (0)10 6338781
Email: info.fi@leviat.com

France

6, Rue de Cabanis
FR 31240 L'Union
Toulouse
Tel: +33 - 5 - 34 25 54 82
Email: info.fr@leviat.com

Germany

Liebigstrasse 14
40764 Langenfeld
Tel: +49 - 2173 - 970 - 0
Email: info.de@leviat.com

India

309, 3rd Floor
Orion Business Park
Ghodbunder Road
Kapurbawdi, Thane West,
Thane, Maharashtra 400607
Tel: +91 - 22 2589 2032
Email: info.in@leviat.com

Italy

Via F.lli Bronzetti 28
24124 Bergamo
Tel: +39 - 035 - 0760711
Email: info.it@leviat.com

Malaysia

28 Jalan Anggerik Mokara 31/59
Kota Kemuning,
40460 Shah Alam Selangor
Tel: +603 - 5122 4182
Email: info.my@leviat.com

Netherlands

Oostermaat 3
7623 CS Borne
Tel: +31 - 74 - 267 14 49
Email: info.nl@leviat.com

New Zealand

PO Box 33232
Barrington
Christchurch 8244
Tel: +64 - 3 376 5205
Email: info.nz@leviat.com

Norway

Vestre Svanholmen 5
4313 Sandnes
Tel: +47 - 51 82 34 00
Email: info.no@leviat.com

Philippines

2933 Regus, Joy Nostalg,
ADB Avenue, Ortigas Center
Pasig City
Tel: +63 - 2 7957 6381
Email: info.ph@leviat.com

Poland

Ul. Obornicka 287
60-691 Poznań
Tel: +48 - 61 - 622 14 14
Email: info.pl@leviat.com

Singapore

14 Benoi Crescent
Singapore 629977
Tel: +65 - 6266 6802
Email: info.sg@leviat.com

Spain

Polígono Industrial Santa Ana
c/ Ignacio Zuloaga, 20
28522 Rivas-Vaciamadrid
Tel: +34 - 91 632 18 40
Email: info.es@leviat.com

Sweden

Vädursgatan 5
412 50 Göteborg
Tel: +46 - 31 - 98 58 00
Email: info.se@leviat.com

Switzerland

Grenzstrasse 24
3250 Lyss
Tel: +41 (0)800 22 66 00
Email: info.ch@leviat.com

United Arab Emirates

RA08 TB02, PO Box 17225
JAFZA, Jebel Ali, Dubai
Tel: +971 (0)4 883 4346
Email: info.ae@leviat.com

United Kingdom

President Way,
President Park,
Sheffield S4 7UR
Tel: +44 - 114 275 5224
Email: info.uk@leviat.com

USA / Canada

6467 S Falkenburg Road
Riverview, FL 33578
Tel: (800) 423-9140
Email: info.us@leviat.us

For countries not listed
Email: info@leviat.com

Notes regarding this document

© Protected by copyright. The information in this publication is based on state-of-the-art technology at the time of publication. In every case, project working details should be entrusted to appropriately qualified and experienced persons. Leviat shall not accept liability for the accuracy of the information in this document or for any printing errors. We reserve the right to make technical and design changes at any time. With a policy of continuous product development, Leviat reserves the right to modify product design and specification at any time.

Contact Leviat locally

For more information on the products featured here, please contact Leviat:

For more information on the following products, please contact:

Masonry, Structural and Precast Concrete products:

1300 304 320
info.ancon.au@leviat.com
Ancon.com.au

Concrete Floor Jointing products:

1800 335 215
info.connolly.au@leviat.com
Connollykeyjoint.com
info.isedio.au@leviat.com
Isedio.com.au

Remedial Masonry products:

1300 667 071
info.helifix.au@leviat.com
Helifix.com.au

General Enquiries

T: 1300 304 320
Leviat.com

Sales Offices and Production

New South Wales, Sydney

Unit A, 1 Heinrich Close,
Eastern Creek | Sydney
NSW 2766

Queensland

17 Goodman Place
Murarrie | Brisbane
QLD 4172

New South Wales, Casino

10 Irving Drive
Casino
NSW 2470

South Australia

Unit 2/35-37 Maxwell Road
Laverton North | Adelaide
SA 5095

Victoria

9/63-69 Pipe Road
Laverton North | Melbourne
VIC 3026

Western Australia

18 Tennant Street
Welshpool | Perth
WA 6106

Leviat®

Imagine. Model. Make.

Leviat.com