

Leviat®

Ancon®

Ancon EdjPro Lifting Systems

For the Precast Concrete Industry



Faster, safer,
higher quality
precast concrete
construction

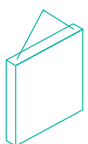

Lifting & Bracing
Precast Lifting

Imagine. Model. Make.

Leviat

We imagine, model and make engineered products and innovative construction solutions that help turn architectural visions into reality and enable our construction partners to build better, safer, stronger and faster.

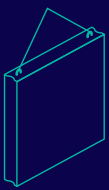

Lifting & Bracing

Systems for the safe and efficient transportation, lifting and temporary bracing of cast concrete elements and tilt-up panels before permanent structural connections are made.

- Precast Lifting
- Tiltup Lifting
- Bracing & Anchorage

Other areas of expertise:

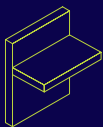

Structural Connections

Systems to form robust, efficient connections, and continuity of concrete reinforcement as necessary, between walls, slabs, columns, beams and balconies, providing structural integrity as well as enhanced thermal and acoustic performance.

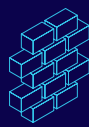

Façade Support & Restraint

Systems for the safe and thermally-efficient fixing of the external building envelope, including brick and natural stone, insulated sandwich panels, curtain walling and suspended concrete façades, and also the repair and strengthening of existing masonry installations.

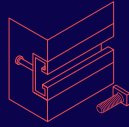

Anchoring & Fixing

Systems for fixing secondary fixtures to concrete, including anchor channels, bolts and inserts; also tension rod systems for roofs and canopies.



Formwork & Site Accessories

Non-structural accessories that complement our engineered solutions and help keep your construction environment operating safely and efficiently, including moulds for casting standard and special concrete elements and construction essentials such as reinforcing bar spacers.

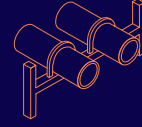

Industrial Technology

Mounting channels, pipe clamps and other versatile framing systems that provide safe fixing in a wide range of industrial applications.

Leviat product ranges:

Ancon | Aschwanden | Connolly | Halfen | Helifix | Isedio | Meadow Burke | Modersohn | Moment | Plaka | Scaldex | Thermomass

Ancon EdjPro Lifting Systems

Why Choose Ancon EdjPro?

- ✓ EdjPro anchors have a removable plug to prevent concrete entering the lifting hole
- ✓ Recess formers fit like a glove, providing a gap between the anchor and concrete
- ✓ The clutch is clear of the concrete edge and has a safer locking ring design
- ✓ Clutches are compatible with previous anchor versions
- ✓ EdjPro systems are compliant with AS 3850.1:2024

Conventional Lifting Systems

Worn or poorly fitted conventional recess formers frequently cause lifting holes to become blocked. The use of Ancon EdjPro lifting systems prevents this and avoids difficult and time consuming on-site hole cleaning, reducing installation costs.



Examples of blocked lifting holes

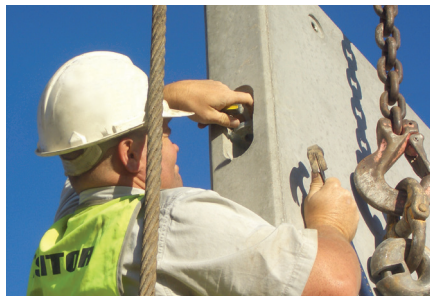

On-site maintenance work required to clean lifting holes

Ancon EdjPro Lifting Systems

An integrated plug prevents concrete ingress into the lifting hole. The plug is simply removed on-site.



Clean, maintenance-free lifting holes

Our aim:

**No cracking, no spalling, no patching.
Faster, safer manufacture,
handling and installation**

The Ancon EdjPro Range

Anchor code	System colour	Compatible clutch code	Compatible recess code	Head style	Maximum WLL (tonnes)	Anchor length (mm)	Anchor width (mm)	Recess width (mm)
EPA04	Silver	EPLC04	EPRF04	Classic Flat	4	200	40	55
NEW EPHIMini	Purple	EPLCMini2	EPRFMini	HI	8.5	200	40	50
EPNA10	Green	EPLCMax	EPNRF10	Classic Flat	10	275	70	70
NEW EPHIMax	Green	EPLCMax	EPRFMax	HI	15	250	55	65

Detailed design specifications are provided in the EdjPro Design Guide, including dimensions for all components and tension bars.

Ancon EdjPro Lifting Systems

Ancon EdjPro EPA04 Edge Lifting System

The EdjPro EPA04 Edge Lifting System is the smallest anchor in the EdjPro range. The narrow system components provide a Working Load (WLL) of 4 tonnes in tension for panels as thin as 100mm.

All components are designed around the thin EPA04 anchor to provide the maximum possible concrete cover while ensuring the required clearance to the surrounding concrete. This avoids concrete spalling during the introduction of shear loads.

Reliable

- ✓ All the benefits of the established EdjPro system with a narrow 4T WLL anchor & recess for thin panels from 100mm

Strong

- ✓ Up to 4T WLL when used with a 12mm tension bar

Versatile

- ✓ The EdjPro clutch and Epa04 provide high performance for edge lifting in the factory, during transportation and erection

Safe

- ✓ Anchor code, WLL and batch number are clearly visible when cast into concrete
- ✓ Complies with the requirements of AS 3850.1:2024

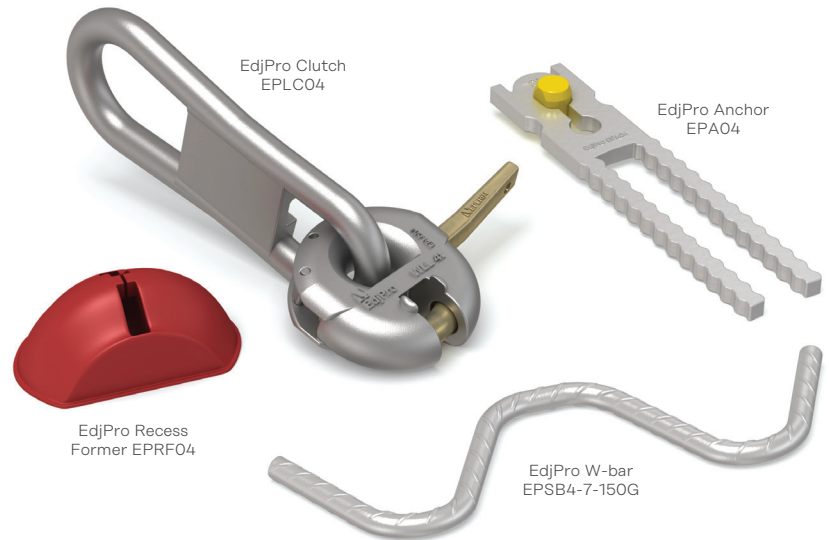

For light precast panels from 100mm thickness



COMPLIANT
AS 3850.1:2024

Ancon EdjPro EPNA10 Edge Lifting System

The EdjPro EPNA10 Edge Lifting System provides a Working Load (WLL) of up to 10 tonnes when used with 20mm tension bar for panels as thin as 125mm. All components have been designed to provide the maximum clearance from the clutch to the concrete panel edge to avoid concrete spalling. For step-joint panels the anchor can also be used in combination with the EdjPro EzyTurn Clutch.

Reliable

- ✓ All the benefits of the established EdjPro system with a narrower anchor and recess for thin panels from 125mm
- ✓ Ideal for thin panels with step joints

Strong

- ✓ Up to 10T WLL when used with a 20mm tension bar

Safe

- ✓ Anchor code, WLL and batch number are clearly visible when cast into concrete
- ✓ Complies with the requirements of AS 3850.1:2024



For light precast panels from 125mm thickness



COMPLIANT
AS 3850.1:2024

NEW Ultra-slim, high load edge-lifting systems

Ancon EPHIMini and EPHIMax Lifting Systems

The Ancon EdjPro EPHI range offers ultra-slim, high load edge lifting solutions for thin precast concrete elements. Our range has been specifically designed for the Australian construction industry and comprises the EdjPro EPHIMax, which allows two-point lifts of precast panels up to 21.7 tonnes, and the EdjPro EPHIMini which is suitable for panels up to 12.3 tonnes when lifted with 2 anchors and incorporating a sling angle of 60°.



COMPLIANT
AS 3850.1:2024

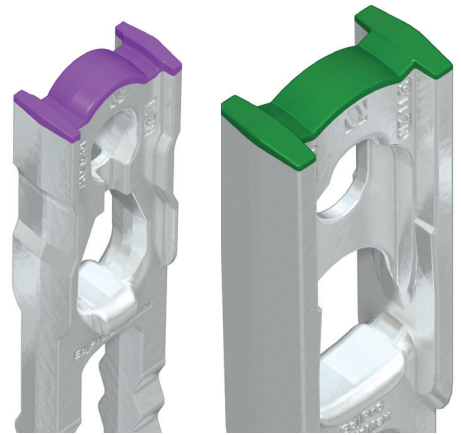

Ultra-slim, high working loads

- ✓ Easily fits into double layer congested reinforcement



I-beam shear foot

- ✓ No need for shear bars in most applications

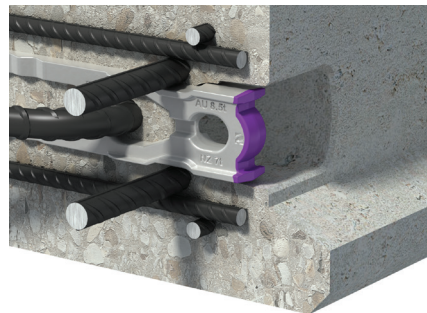

EdjPro EPLCMini Clutch

The EdjPro EPHIMini Anchor works in conjunction with the EdjPro EPLCMini2 Clutch



Unique I-beam heads

- ✓ Exceptional stiffness & load transfer
- ✓ Prevents head distortion or shear failure
- ✓ Interlocks with the clutch to limit rotation
- ✓ Prevents bearing, concrete cracking and spalling

PATENTED



Easily identifiable

- ✓ I-beam head is unmistakable - identification is easy for clutch compatibility. Integrated plug prevents concrete ingress into clutch holes.



Clutch clearance even in step-joints



Ultra tough forged alloy steel

- ✓ Hot dip galvanised high strength alloy steel



SUPERIOR PERFORMANCE

Optimised tension bar WLLs

- ✓ New anchor shape maximises tension bar WLL and reliability

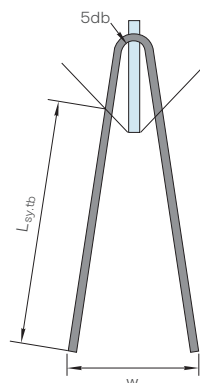

Fast lifting off the bed

- ✓ No need to creep the crane when lifting off the bed



Ancon EdjPro Lifting Systems

How EdjPro Systems Prevent Cracks

Conventional flat-head systems can spall edges. Ancon EdjPro lifting systems provide fast, clean, safe connections in all directions including clutch and anchor concrete clearance.

Conventional flat-head anchor systems

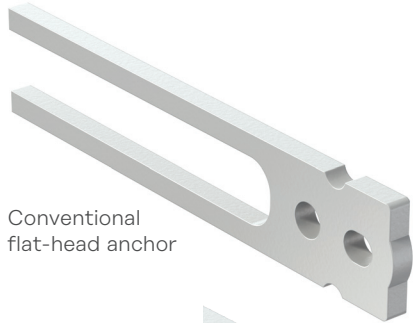

Conventional flat-head anchor



Conventional clutch has a round locking ring so the clutch is free to rotate around the anchor under shear load.

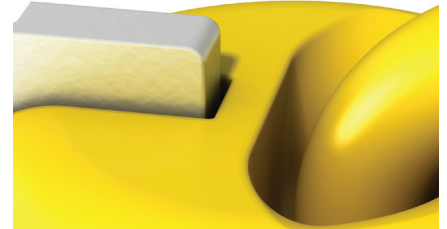

Rotation causes the side of the clutch to bear against the top of the anchor causing a shearing force to the side.

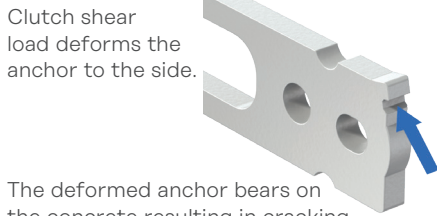

Clutch shear load deforms the anchor to the side.

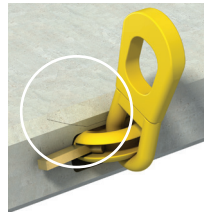

Anchor bearing crack



Clutch bearing crack

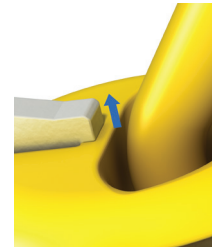
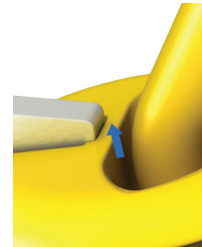

The deformed anchor bears on the concrete resulting in cracking, causing further rotation. This results in the clutch torus and handle spalling the concrete.

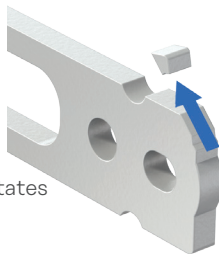

The clutch fully rotates and the concrete spalls away.

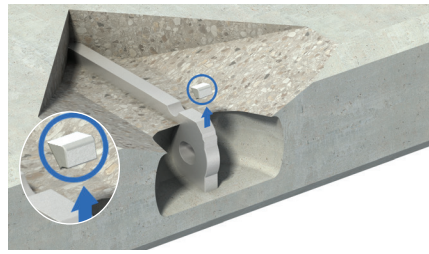

Anchor sheared by the clutch



Complete rotation and failure

The EdjPro Solution

Ancon EdjPro I-beam anchor

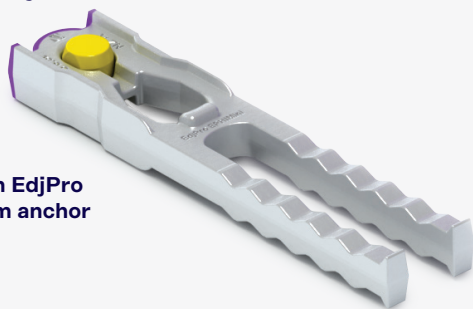

The locking ring is not round therefore restricts rotation.

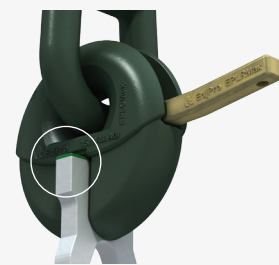

EPNA systems have more distance between the clutch and anchor sides which increases shear resistance.

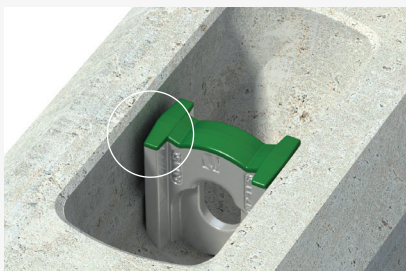

The gap allows the anchor to deflect under load without concrete contact, preventing cracking. All EdjPro systems have a gap between the anchor and concrete.

Anchor flanges limit rotation, prevent concrete contact and cracking. The ultimate solution EPHI I-beam head.



Clutch bears on the anchor flanges, avoiding shear failure.

Ancon EdjPro Anchor Systems comply with AS 3850.1:2024

AS 3850 Clause	Requirement	
1.4.35	A lifting insert is a component or a system. EdjPro Anchors and tension bars are two components of a lifting insert system.	✓
1.4.12	A tension bar (component reinforcement) is a component which is required to achieve the working load of a lifting system.	✓
1.4.37	EdjPro Anchors are plate style inserts, essentially planar in form.	✓
2.2	The Working Load Limit (WLL) has a factor of Safety of 2.25 against the critical characteristic strength R_u (effectively the minimum breaking strength), determined by testing according to Appendix A.	✓
2.5.2.1	EdjPro EPHI Anchors are forged from fully killed steel with grain size less than 6 (AS 1733), elongation not less than 15% for martensitic or 20% for pearlitic steels, and a 100% fibrous failure surface consistent with ductile failure when loaded intension. EdjPro Anchors are tested in and out of concrete in accordance with Appendix A and are marked for visible confirmation of compatibility. EdjPro Anchors and Recess Formers are marked for compatibility.	✓
Table 2.2	Maximum Carbon 0.25%, Phosphorous 0.05%, Sulphur 0.05%.	✓
2.5.2.2	Plate style inserts must have a tension bar (component reinforcement). EdjPro Anchors are designed to always be used with a tension bar.	✓
	An edge lift insert must be tested in accordance with Appendix A, with and without its tension bar to determine the characteristic strength R_u and WLL.	✓
2.5.2.2	The tension bar is one component of the lifting insert system, the other component is the plate style insert. The WLL for the system is based on the minimum characteristic strength of the system.	✓
C2.5.2.2	The critical mode of failure of tension bars is "double shear" at the anchor aperture. R_u of tension bars is limited to the tested shear strength of AS 4671 N class bars manufactured with the minimum tensile strength (540MPa). When tested in concrete of the design lifting strength, the R_u of the anchor without the tension bar is not less than the anchor WLL.	✓
Appendix A	Anchor testing must conform with Appendix A, parts A1, A2, A3, A4, A6 & A7.	✓
Appendix A1.5	R_u is the critical characteristic strength which has a 95% probability of being exceeded at a confidence of 90%, of a component or system.	✓
Appendix A3.1 Appendix A6	Each component and the insert system (plate style insert + tension bar) to determine the critical mode of failure and critical characteristic strength.	✓



COMPLIANT
AS 3850.1:2024

Contact Leviat locally

For more information on the products featured here, please contact Leviat:

For more information on the following products, please contact:

Masonry, Structural and Precast Concrete products:

1300 304 320
info.ancon.au@leviat.com
Ancon.com.au

Concrete Floor Jointing products:

1800 335 215
info.connolly.au@leviat.com
Connollykeyjoint.com
info.isedio.au@leviat.com
Isedio.com.au

Remedial Masonry products:

1300 667 071
info.helifix.au@leviat.com
Helifix.com.au

General Enquiries

T: 1300 304 320
Leviat.com

Sales Offices and Production

New South Wales, Sydney

Unit A, 1 Heinrich Close,
Eastern Creek | Sydney
NSW 2766

Queensland

17 Goodman Place
Murarrie | Brisbane
QLD 4172

New South Wales, Casino

10 Irving Drive
Casino
NSW 2470

South Australia

Unit 2/35-37 Maxwell Road
Laverton North | Adelaide
SA 5095

Victoria

9/63-69 Pipe Road
Laverton North | Melbourne
VIC 3026

Western Australia

18 Tennant Street
Welshpool | Perth
WA 6106

Contact Leviat worldwide

Australia

Unit A, 1 Heinrich Close,
Eastern Creek, Sydney, NSW 2766
Tel: +61 - 2 8808 3100
Email: info.au@leviat.com

Austria

Leonard-Bernstein-Str. 10 Saturn
Tower, 1220 Wien
Tel: +43 - 1 - 259 6770
Email: info.at@leviat.com

Belgium

Industrielaan 2
1740 Ternat
Tel: +32 - 2 - 582 29 45
Email: info.be@leviat.com

China

Room 601 Tower D,
Vantone Centre
No. A6 Chao Yang Men Wai Street
Chaoyang District
Beijing P.R. China 100020
Tel: +86 - 10 5907 3200
Email: info.cn@leviat.com

Czech Republic

Business Center Šafránková
Šafránková 1238/1
155 00 Praha 5
Tel: +420 - 311 - 690 060
Email: info.cz@leviat.com

Finland

Vädursgatan 5
412 50 Göteborg / Sweden
Tel: +358 (0)10 6338781
Email: info.fi@leviat.com

France

6, Rue de Cabanis
FR 31240 L'Union
Toulouse
Tel: +33 - 5 - 34 25 54 82
Email: info.fr@leviat.com

Germany

Liebigstrasse 14
40764 Langenfeld
Tel: +49 - 2173 - 970 - 0
Email: info.de@leviat.com

India

309, 3rd Floor
Orion Business Park
Ghodbunder Road
Kapurbawdi, Thane West,
Thane, Maharashtra 400607
Tel: +91 - 22 2589 2032
Email: info.in@leviat.com

Italy

Via F.lli Bronzetti 28
24124 Bergamo
Tel: +39 - 035 - 0760711
Email: info.it@leviat.com

Malaysia

28 Jalan Anggerik Mokara 31/59
Kota Kemuning,
40460 Shah Alam Selangor
Tel: +603 - 5122 4182
Email: info.my@leviat.com

Netherlands

Oostermaat 3
7623 CS Borne
Tel: +31 - 74 - 267 14 49
Email: info.nl@leviat.com

New Zealand

PO Box 33232
Barrington
Christchurch 8244
Tel: +64 - 3 376 5205
Email: info.nz@leviat.com

Norway

Vestre Svanholmen 5
4313 Sandnes
Tel: +47 - 51 82 34 00
Email: info.no@leviat.com

Philippines

2933 Regus, Joy Nostalg,
ADB Avenue, Ortigas Center
Pasig City
Tel: +63 - 2 7957 6381
Email: info.ph@leviat.com

Poland

Ul. Obornicka 287
60-691 Poznań
Tel: +48 - 61 - 622 14 14
Email: info.pl@leviat.com

Singapore

14 Benoi Crescent
Singapore 629977
Tel: +65 - 6266 6802
Email: info.sg@leviat.com

Spain

Polígono Industrial Santa Ana
c/ Ignacio Zuloaga, 20
28522 Rivas-Vaciamadrid
Tel: +34 - 91 632 18 40
Email: info.es@leviat.com

Sweden

Vädursgatan 5
412 50 Göteborg
Tel: +46 - 31 - 98 58 00
Email: info.se@leviat.com

Switzerland

Grenzstrasse 24
3250 Lyss
Tel: +41 (0)800 22 66 00
Email: info.ch@leviat.com

United Arab Emirates

RA08 TB02, PO Box 17225
JAFZA, Jebel Ali, Dubai
Tel: +971 (0)4 883 4346
Email: info.ae@leviat.com

United Kingdom

President Way,
President Park,
Sheffield S4 7UR
Tel: +44 - 114 275 5224
Email: info.uk@leviat.com

USA / Canada

6467 S Falkenburg Road
Riverview, FL 33578
Tel: (800) 423-9140
Email: info.us@leviat.us

For countries not listed
Email: info@leviat.com

Notes regarding this document

© Protected by copyright. The information in this publication is based on state-of-the-art technology at the time of publication. In every case, project working details should be entrusted to appropriately qualified and experienced persons. Leviat shall not accept liability for the accuracy of the information in this document or for any printing errors. We reserve the right to make technical and design changes at any time. With a policy of continuous product development, Leviat reserves the right to modify product design and specification at any time.

Leviat®

Imagine. Model. Make.

Leviat.com