

Leviat®

QwikBrace

High strength anchor system,
featuring continuously-rolled
Unicoil™ bars, for the bracing
of precast wall panels



- Fast and simple to install
- Suitable for use in low strength concrete
- Meets the requirements of AS 3850:2015

Located
Nationwide

Ancon®

Ancon QwikBrace Anchor System

High strength cast-in anchorage for the fixing of a slot-footed wall brace; also suitable for anchoring safety barriers, handrails and other site fixtures.

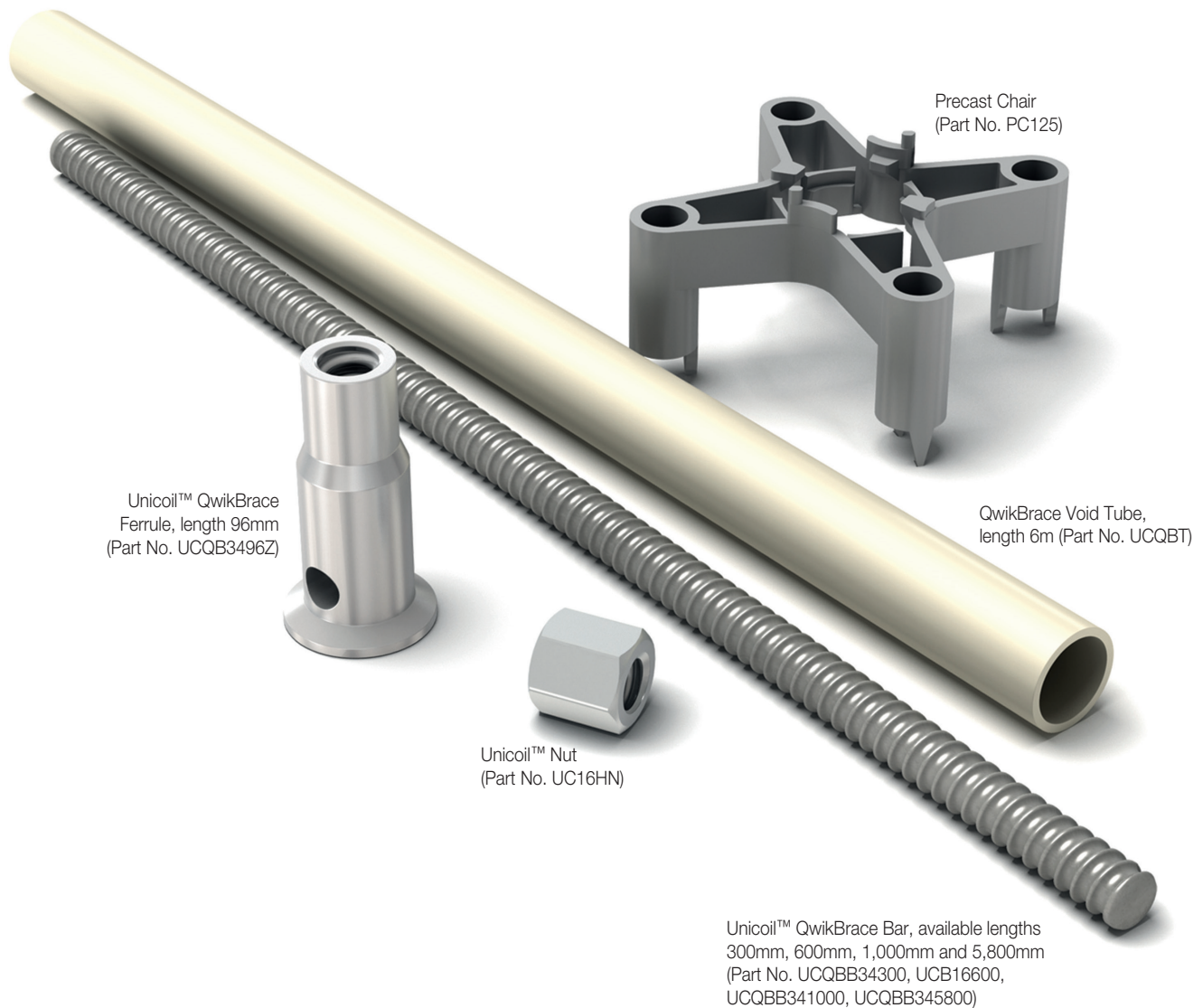

Performance

The smooth continuously-rolled Unicoil™ bar is easier to engage and faster to install than standard metric threaded systems; manufactured from high manganese alloy steel, it is stronger than N16 reinforcing bar. ¾" Unicoil 16 bar has a characteristic ultimate tensile strength of 156kN and a shear strength of 96kN.

With a bearing area over four times the area of the bar, the QwikBrace Ferrule is a headed anchorage that exceeds the requirements of AS 3600:2009 and AS 3850.1:2015.

The table provides Working Load Limits for the axial load of the connected brace (kN) for QwikBrace anchors used in slabs with varying slab thickness and different concrete strengths in accordance with AS 3850.1:2015 and testing including a factor of safety of 2.25.

For more information on capacities at other conditions please contact the Leviat technical team.

Tightening Torque

Unlike expansion anchors, QwikBrace systems do not rely on tightening torque to prevent pull-out. To minimise loosening of the QwikBrace system under wind loads, nuts should be tightened to a torque of 100Nm or snug tightened and turned a further 1/3rd of a turn.

Leviat recommends the use of a calibrated torque wrench to limit the torque during the installation. Higher installation torques can damage the bar, the threaded insert or the surrounding concrete.

Slab Thickness t (mm)	Effective Embedment h_{eff}^{**} (mm)	Min Edge Distance $1.5 \cdot h_{eff}$ (mm)	WLL of the axial brace Load B^* (kN) based on Concrete Compressive Strength f_{cm} (MPa)					
			8 (kN)	10 (kN)	15 (kN)	20 (kN)	25 (kN)	30 (kN)
125	95	145	12.3	13.7	16.8	19.4	21.7	23.8
150	120	180	17.4	19.4	23.8	27.5	29.9	33.7
180	150	225	24.3	27.2	33.3	38.4	43.0	47.1
200	170	255	29.3	32.8	40.1	46.4	51.9	56.8
250	220	330	43.1	48.2	58.5	58.5	58.5	58.5
300	270	405	58.5	58.5	58.5	58.5	58.5	58.5

* - for a brace angle of $\alpha = 60^\circ$

** - with precast chair PC125

Blue capacities based on steel strength of Unicoil

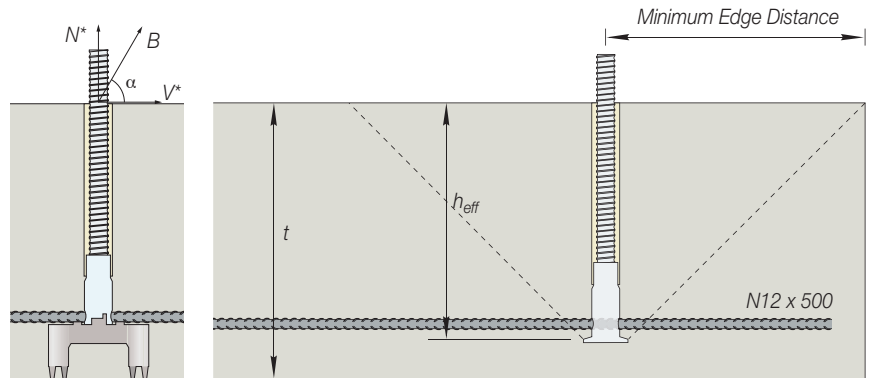

Edge Distances

Where possible, QwikBrace anchors should be located well away from edges at edge distances exceeding the recommended distances shown in the table. Where anchors are to be located closer than the minimum edge distance, refer to Leviat for guidance.

Anchor Spacing

The minimum anchor spacing is twice the edge distances in the table.

Two Step Installation

Step 1

The precast chair, ferrule and tube is assembled squarely on the formwork. Reinforcement is located and the concrete is poured. The tube is left proud of the slab to identify the fixing location and show that the assembly remained perpendicular during casting.

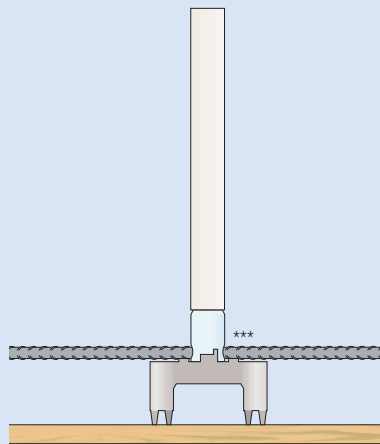

Step 2

The tube is cut off flush with the slab and the Unicoil bar is passed through the void and screwed into the ferrule. The Unicoil nut secures the fixture in place. The bar and nut are re-useable.

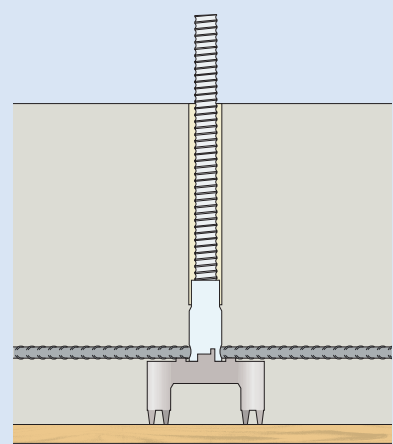

*** Cross-bar is required for fixing only, capacities in the table are achieved without bar.

Leviat®

For more information on these products, contact:

Leviat

Unit A, 1 Heinrich Close,
Eastern Creek, Sydney
NSW 2766
Australia

Tel: 1300 304320

Email: info.ancon.au@leviat.com

Ancon.com.au
Leviat.com

Sales Offices and Production

New South Wales, Sydney

98 Kurrajong Avenue
Mount Druitt | Sydney
NSW 2770

New South Wales, Casino

10 Irving Drive
Casino
NSW 2470

Victoria

9/63-69 Pipe Road
Laverton North | Melbourne
VIC 3026

Queensland

4/15 Terrace Place
Murarrie | Brisbane
QLD 4172

South Australia

Unit 2/35-37 Maxwell Road
Laverton North | Adelaide
SA 5095

Western Australia

18 Tennant Street
Welshpool | Perth
WA 6106