

Ancon®

Ancon EdjPro EPHIMini

Edge Lifting System

The optimum solution for most plain and step-joint precast panels

The EdjPro EPHIMini Edge Lifting System has been specifically developed to be used in the Australian construction industry for 100-200mm thick precast panels. The unique I-shaped anchor combines maximum capacity and stiffness with a narrow anchor design for thin, heavily reinforced panels. As with all anchors in the Ancon EdjPro series, the EPHIMini complies with the latest revision of Australian Standard AS3850.



Ultra narrow, HI working load

- 8.5T WLL, 40mm wide anchor, 50mm recess
- For all panels from 100mm thickness

New I-beam head

- Restricts clutch rotation
- Lowers the risk of concrete cracking and spalling

Plain & 'Step-Joint' Panels

- Perfect solution for step-joint, 'weather seal' panels
- Narrow shape for maximum edge distances
- EdjPro clutch clears the concrete when edge lifting
- Stronger performance: factory, transportation and erection

Safe

- 8.5T WLL when used with a 16mm tension bar
- Complies with AS3850.1:2024

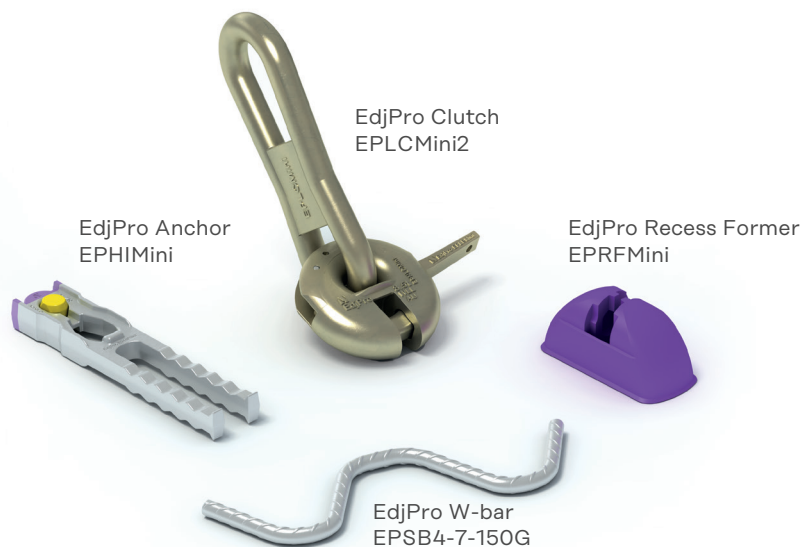

EdjPro Clutch
EPLCMini2

EdjPro Anchor
EPHIMini

EdjPro Recess Former
EPRFMini

EdjPro W-bar
EPSB4-7-150G

Ancon EdjPro EPHIMini

N16 Tension Bar details

The EdjPro Mini anchor must be used with a N16 tension bar in accordance with AS/NZS 4671:2019 Grade 500N. The nominated leg length required is 500mm. The use of this tension bar is to ensure that the anchor meets with the ultimate strength as required in AS3850.1:2024. Leviat recommends a 45 degree bend Diagram 1 but can alternatively be bent at 30-60 degrees see Diagram 2. If further information is required please contact Leviat.

System Performance Working Loads in Tension

In accordance to AS 3850.1:2024

Panel Thickness (mm)	Part No.	Concrete Strengths			
		15MPa	20MPa	25MPa	32MPa
100	EPHIMini Purple	6.1t	6.7t	7.0t	7.3t
125	EPHIMini Purple	6.5t	7.0t	7.75t	8.25t
150	EPHIMini Purple	7.0t	7.75t	8.5t	8.5t
175	EPHIMini Purple	7.25t	8.0t	8.5t	8.5t
200	EPHIMini Purple	7.5t	8.25t	8.5t	8.5t

For further technical assistance please contact the Leviat Precast Engineering team.

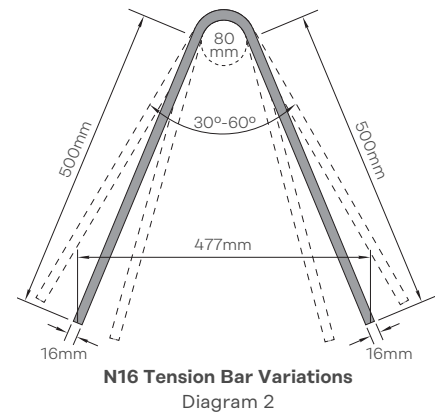
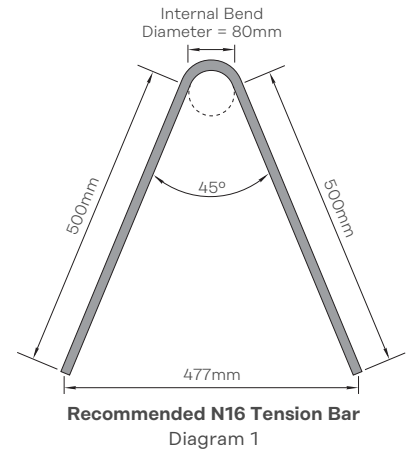

Working Load Limits in Shear (tonnes); During demoulding by tilting from horizontal to vertical (One edge of panel Supported on Ground)

Panel Thickness (mm)	Trimmer bar (perimeter bar)	Shear Reinforcement	Concrete strength at time of lift f_{lift}					
			12MPa	15MPa	20MPa	25MPa	30MPa	40MPa
100	N12	Trimmer bar only	1.45t	1.6t	1.85t	2.1t	2.3t	2.65t
		Trimmer bar + N12 Shear Bar	1.65t	1.85t	2.15t	2.4t	2.6t	3.05t
125	N12	Trimmer bar only	1.65t	1.85t	2.15t	2.4t	2.65t	3.05t
		Trimmer bar + N12 Shear Bar	1.9t	2.15t	2.45t	2.75t	3.0t	3.5t
150	N16	Trimmer bar only	1.9t	2.1t	2.45t	2.75t	3.0t	3.5t
		Trimmer bar + N12 Shear Bar	2.15t	2.45t	2.8t	3.15t	3.45t	3.6t
175	N16	Trimmer bar only	2.15t	2.4t	2.75t	3.1t	3.4t	3.6t
		Trimmer bar + N12 Shear Bar	2.45t	2.75t	3.15t	3.55t	3.6t	3.6t
200	N16	N16 Trimmer bar only	2.4t	2.7t	3.1t	3.45t	3.6t	3.6t
		Trimmer bar + N12 Shear Bar	2.75t	3.05t	3.55t	3.6t	3.6t	3.6t

Notes: Locate the perimeter bar above the EdjPro anchor to control flexural cracking. N12 shear 'omega' bars and edge reinforcement e.g. hooked or U-bars help control shear cracking at higher loads. The standard shear bar is optimised for 125-150mm thick panels. Multiple bars or larger diameter bars with deeper embedment may improve crack control in thick (175-200mm) panels. Panel cracking and shear spalling is possible if the designed loads are exceeded. Some anchor deflection is normal, particularly at large sling angles.

For other panel thicknesses, please consult the Leviat technical team for design advice. The WLLs shown in the tables above are based on a minimum distance equal to the panel thickness between an anchor and any edge or penetration (e.g. a duct) and twice this distance between any two anchors.

If the shear load is sustained after demoulding, supplementary shear reinforcement is required in addition to the trimmer bar.

Please contact Leviat engineering team for advice.

Ancon EdjPro EPHIMini

EdjPro EPHIMini Anchor

Narrow body and high capacity, perfect for thin panels.

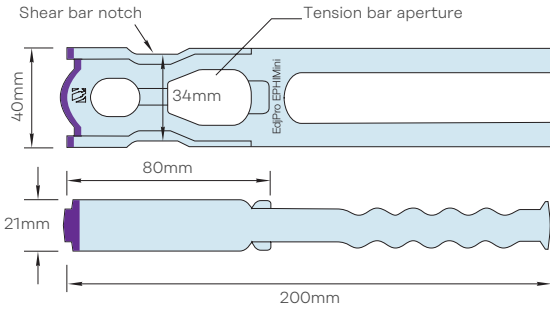

Standard Hot Dip Galvanised N12 'W' Shear Bar EPSB4-7-150G

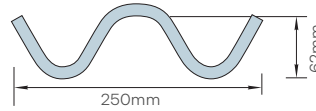

EPHIMini Trimmer Bar & EPSB4-7-150G Shear Bar in 150mm Panel

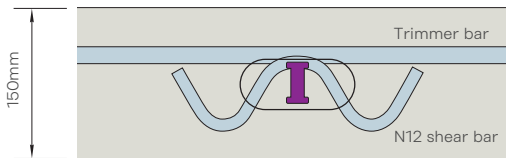

EdjPro Recess Former EPRFMini

Ultra narrow design, oil resistant synthetic rubber.

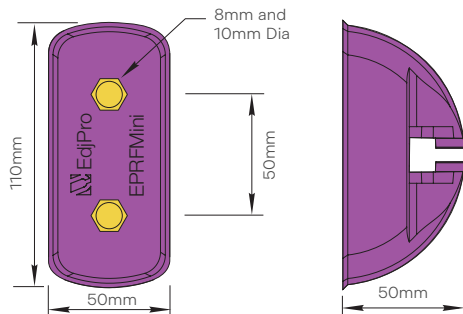

Preferred Rigging: Use a beam to minimise stresses

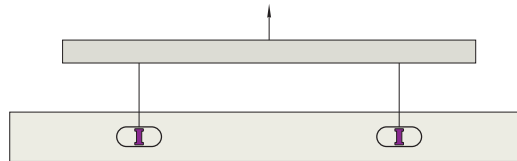

A lifting beam rigged with vertical slings is always preferred i.e. sling angle = 0° to minimise concrete stress in the thin edge. Always limit sling angles to 60° when lifting with or without a beam.

Important! The EPHIMini must be installed with the EPRFMini (or EPNRF07) recess and lifted with the EPLCMini2 clutch (or the compatible but now superseded EPLC07). This system is not compatible with other components without written authorisation from LeviaT.