

Ancon®

Ancon EdjPro EPNA10

Edge Lifting System

For precast panels from 125mm thickness

The EdjPro EPNA10 Edge Lifting System provides a Working Load (WLL) of up to 10 tonnes when used with 20mm tension bar for panels as thin as 125mm. All components have been designed to provide the maximum clearance from the clutch to the concrete panel edge to avoid concrete spalling. For step-joint panels the anchor can also be used in combination with the EdjPro Narrow Clutch.



Reliable

- All the benefits of the established EdjPro system with a narrower anchor and recess for thin panels from 125mm
- Ideal for thin panels with step joints

Strong

- Up to 10T WLL when used with a 20mm tension bar

Safe

- Anchor code, WLL and batch number are clearly visible when cast into concrete
- Complies with the requirements of AS3850.1:2024



EdjPro Clutch EPLCMax

EdjPro Narrow Recess Former EPNRF10

EdjPro Narrow Anchor EPNA10

Ancon EdjPro EPNA10

System Performance

Working Loads in Tension

Anchor Code Colour	Tension bar	Recommended development length $L_{sy.tb}$ (mm)	Total cut length (mm)	Spread width W (mm)	WLL (tonnes)
EPNA10 Green	N16	496	1180	374	7
	N20	634	1460	464	10

Note: An N16 or N20 tension bar may be used according to the required WLL. The development length for the tension bars are based on a concrete strength of 15MPa and a panel thickness of 125mm

Working Loads Limits in Shear (tonnes); During demoulding by tilting from horizontal to vertical (One edge of panel Supported on Ground)

Panel Thickness (mm)	Perimeter (edge) bar	Edge lift capacity (tonnes)						
		Concrete compressive strength at the time of lift f_{lift} (MPa)						
		10	12	15	20	25	30	40
Maximum recommended shear load (tonnes) for EdjPro anchors with tension bars.								
125	N12 or N16	1.60	1.80	2.00	2.30	2.60	2.80	3.20
150	N16	1.90	2.00	2.30	2.60	2.90	3.20	3.50
175	N16	2.10	2.30	2.60	3.00	3.30	3.50	3.50
200	N16	2.40	2.60	2.90	3.30	3.50	3.50	3.50
250	N16	2.90	3.10	3.50	3.50	3.50	3.50	3.50
300	N16	3.30	3.50	3.50	3.50	3.50	3.50	3.50

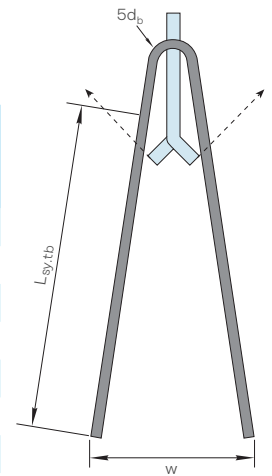

Notes: Locate the N16 perimeter “trimmer” bar above the EdjPro anchor to control flexural cracking. Shear “omega” bars may help control shear cracking at higher loads.

Panel cracking and shear spalling is possible if the recommended loads are exceeded.

For other panel thicknesses, please consult the Leviat technical team for design advice. The WLLs shown in the tables above are based on a minimum distance equal to the panel thickness between an anchor and any edge or penetration (e.g. a duct) and twice this distance between any two anchors.

If the shear load is sustained after demoulding, supplementary shear reinforcement is required in addition to the trimmer bar. Please contact Leviat engineering team for advice.

Ancon EdjPro EPNA10

EdjPro EPNA10 Narrow Anchor

Reduced head width, perfect for thin panels.

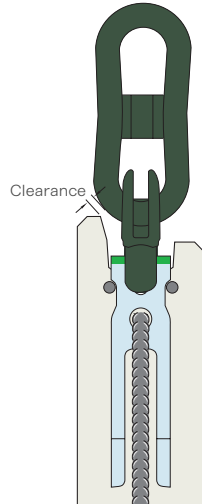
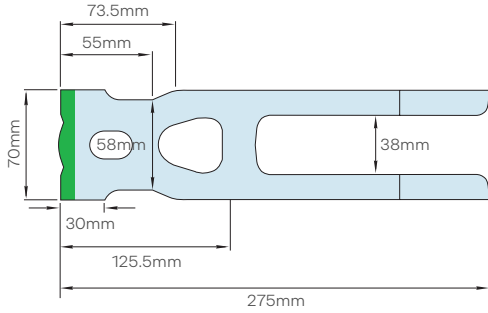

Clearance area leaves panels in perfect condition.

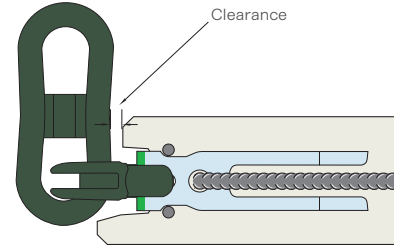

Narrow Recess Former (EPNRF10)

Slender design, perfect for thin panels.

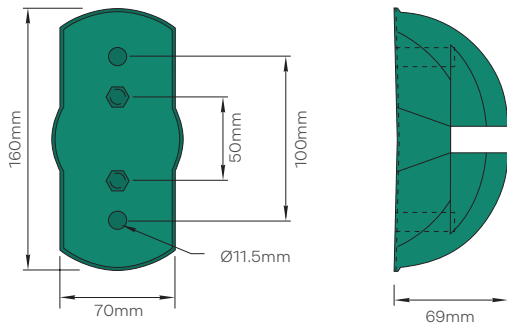

Recommended Rigging

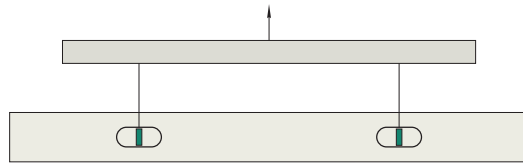

A lifting beam and vertical slings i.e. sling angle = 0° minimises concrete stress in the thin edge. When lifting with slings without a beam, limit sling angles to 60°.

Important! The EPNA10 must be installed with the EPNRF10 recess and lifted with the EPLCMax clutch (or the compatible but now superseded EPLC10). This system is not compatible with other components without written authorisation from Leviat.