

HALFEN POWERCLICK SYSTEM 63

Produktinformation Technik/Technical Product Information



- mit Tragfähigkeiten nach EC3
- *with load capacities acc. to EC3*
- aktualisiert nach Druckgeräterichtlinie 2014/68/EU
- *updated acc. to Pressure Equipment Directive (PED) 2014/68/EU*

Leviat

We imagine, model and make engineered products and innovative construction solutions that help turn architectural visions into reality and enable our construction partners to build better, safer, stronger and faster.

Leviat is a world leader in connecting, fixing, lifting and anchoring technology.

From the build of new schools, hospitals, homes and infrastructure, to the repair and maintenance of heritage structures, our engineering skills are making a difference around the world.

We provide technical design assistance at every stage of a project, from initial planning to installation and beyond.

Our technical support services range from simple product selection through to the development of a fully customised project-specific design solution.

Every promise we make locally, has the commitment and dedication of our global team behind it. We employ almost 3,000 people at 60 locations across North America, Europe and Asia-Pacific, providing an agile and responsive service worldwide.





>3,000
People

60+
Locations

~20
Countries

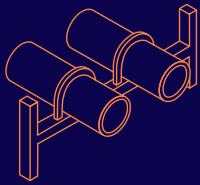

Industrial Technology

Mounting channels, pipe clamps and other versatile framing systems that provide safe fixing in a wide range of industrial applications.

- Modular Framing Systems
- Modular Support Systems
- Mounting Channel Systems
- Accessories for channels, framing & support systems
- General accessories
- Versatile Interior Systems

Other areas of expertise:

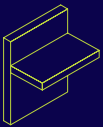

Structural Connections

Systems to form robust, efficient connections, and continuity of concrete reinforcement as necessary, between walls, slabs, columns, beams and balconies, providing structural integrity as well as enhanced thermal and acoustic performance.

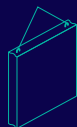

Lifting & Bracing

Systems for the safe and efficient transportation, lifting and temporary bracing of cast concrete elements and tilt-up panels before permanent structural connections are made.

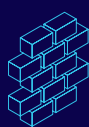

Façade Support & Restraint

Systems for the safe and thermally-efficient fixing of the external building envelope, including brick and natural stone, insulated sandwich panels, curtain walling and suspended concrete façades, and also the repair and strengthening of existing masonry installations.



Anchoring & Fixing

Systems for fixing secondary fixtures to concrete, including anchor channels, bolts and inserts; also tension rod systems for roofs and canopies.



Formwork & Site Accessories

Non-structural accessories that complement our engineered solutions and help keep your construction environment operating safely and efficiently, including moulds for casting standard and special concrete elements and construction essentials such as reinforcing bar spacers.

Leviat product ranges:

Ancon | Aschwanden | Connolly | Halfen | Helifix | Isedio | Meadow Burke | Modersohn | Moment | Plaka | Scaldex | Thermomass

HALFEN POWERCLICK SYSTEM

Powerclick auf einen Blick / Powerclick at a glance

Noch nie war wenig so viel: DREI GRÖSSEN – ein System

Never has so little given so much: THREE SIZES – one system

POWERCLICK SYSTEM 63



Das einzigartige System von umschließenden Verbindungselementen überträgt Biegemomente besser als andere Systeme.

Unique "closed" design of connection elements resists moment forces more effectively than other systems.

Katalog PC 63

Catalogue PC 63



TÜV GEPRÜFT
NACH EN 13480
(BAUMUSTERPRÜFUNG)
POWERCLICK SYSTEM 63
TESTED TO EN 13480
(TYPE TESTED)
BY TÜV

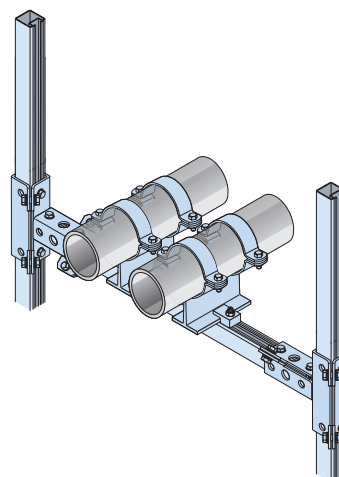

POWERCLICK SYSTEM 41



Vormontierte Verbindungsteile – komfortabel für den Planer und zeitsparend auf der Baustelle.

Pre-assembled connection hardware is convenient for the designer, and saves time on-site.

Katalog PC 41

Catalogue PC 41

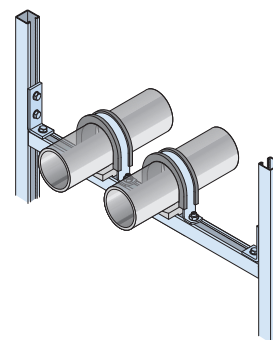
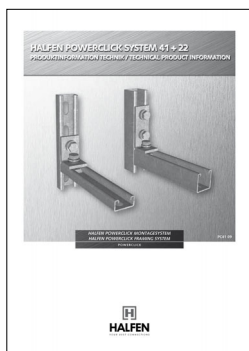

POWERCLICK SYSTEM 22



Für kleine Rohrdurchmesser – kompatibel mit unseren Systemen 63 und 41.

For small diameter piping. Fully compatible with 41 and 63 systems.

Katalog PC 41

Catalogue PC 41

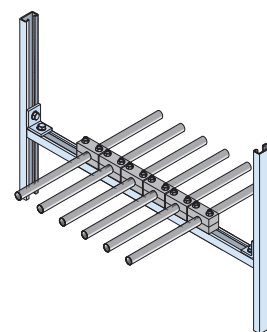
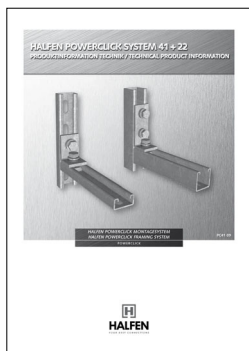

POWERCLICK ZUBEHÖR POWERCLICK ACCESSORIES

Konsolen, Rohrschellen, Gleitlager
Cantilever arms, pipe clamps, sliding supports

Katalog PC Z

Catalogue PC Z

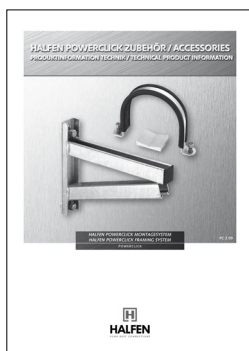

HALFEN POWERCLICK SYSTEM

Einfache und zeitsparende Montage / Simple and Time Saving Assembly

Ein kompatibles System für wirtschaftliche Unterstüzungen

One system compatible with all channels for economical supports

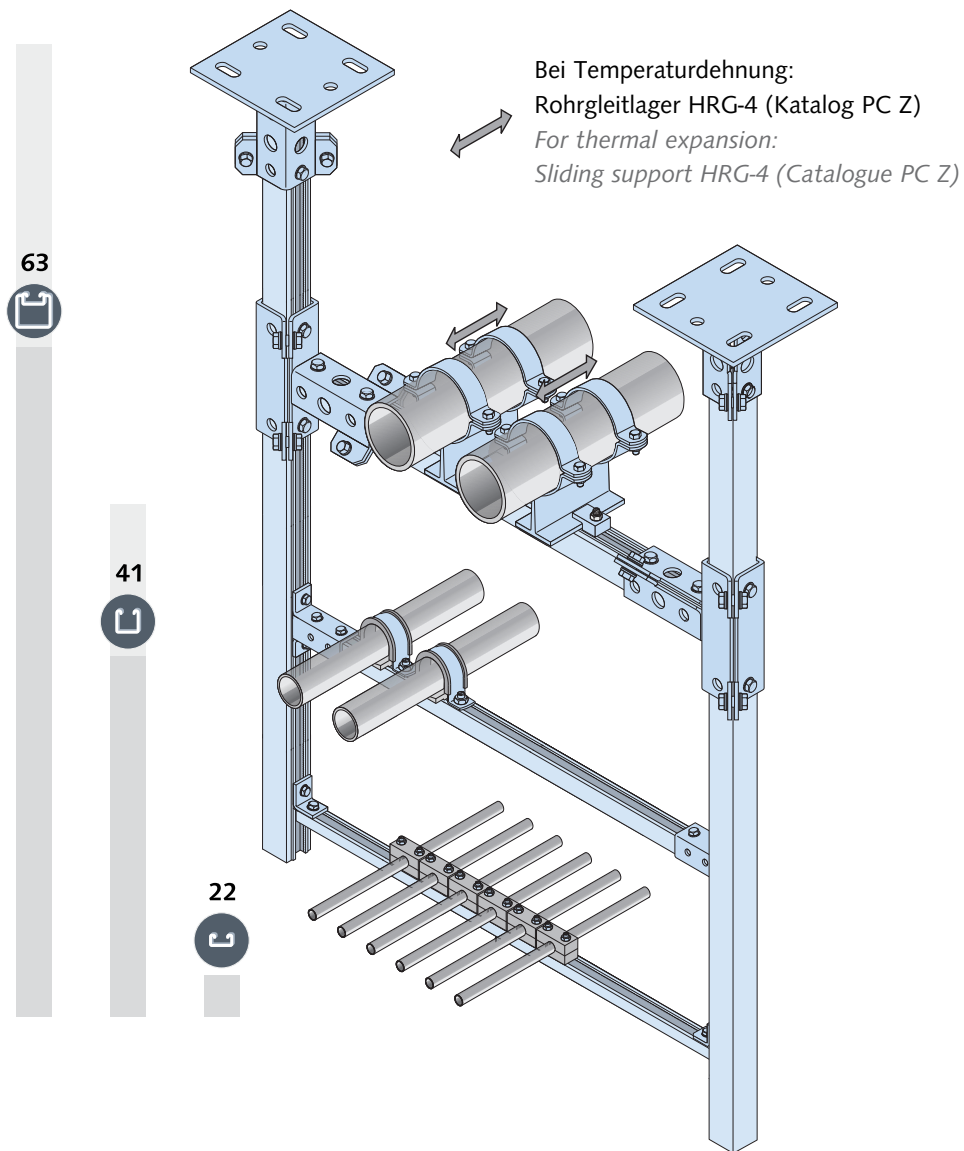

<p>3 Basisprofile 3 Basic profiles</p> <p>Schienenmutter mit "Biss" Serrated channel nut</p>	<p>Profil Channel 63/63</p>	<p>1 Powerclickschraube 1 Powerclick bolt</p>
	<p>Profil Channel 41/41</p>	
	<p>Profil Channel 41/22</p>	

HALFEN POWERCLICK SYSTEM

Powerclick System 63

Noch nie war wenig so viel:

POWERCLICK SYSTEM 63 -

Nur 4 Basisbauteile für räumliche Konstruktionen -
12 Bauteile für 90 % aller Unterstützungsvarianten

Never has so little given so much:

POWERCLICK SYSTEM 63

Only 4 basic components for 3-dimensional support frames
12 components for 90 % of all support applications

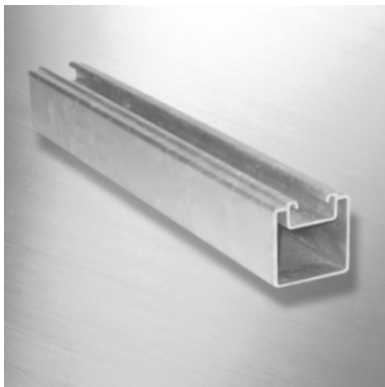

EINE MONTAGESCHIENE
für alle Rohrunterstützungen

ONE FRAMING CHANNEL
for all pipe support frames

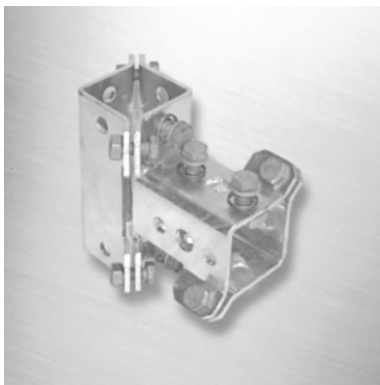

EIN ECKVERBINDER
für räumliche Konstruktionen

ONE ELBOW CONNECTOR
for 3-dimensional systems

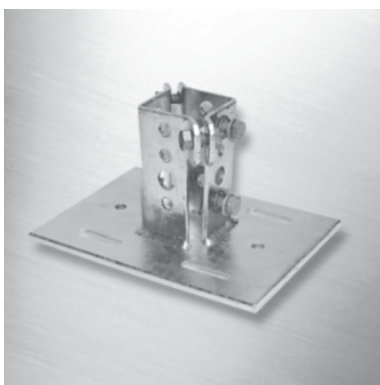

EIN STÜTZENFUSS
für alle Anbindevarianten

ONE BASE SUPPORT TYPE
for all applications



EINE TRÄGERKLEMME
für alle Trägergrößen

ONE BEAM CLAMP
fits all steel beam sizes

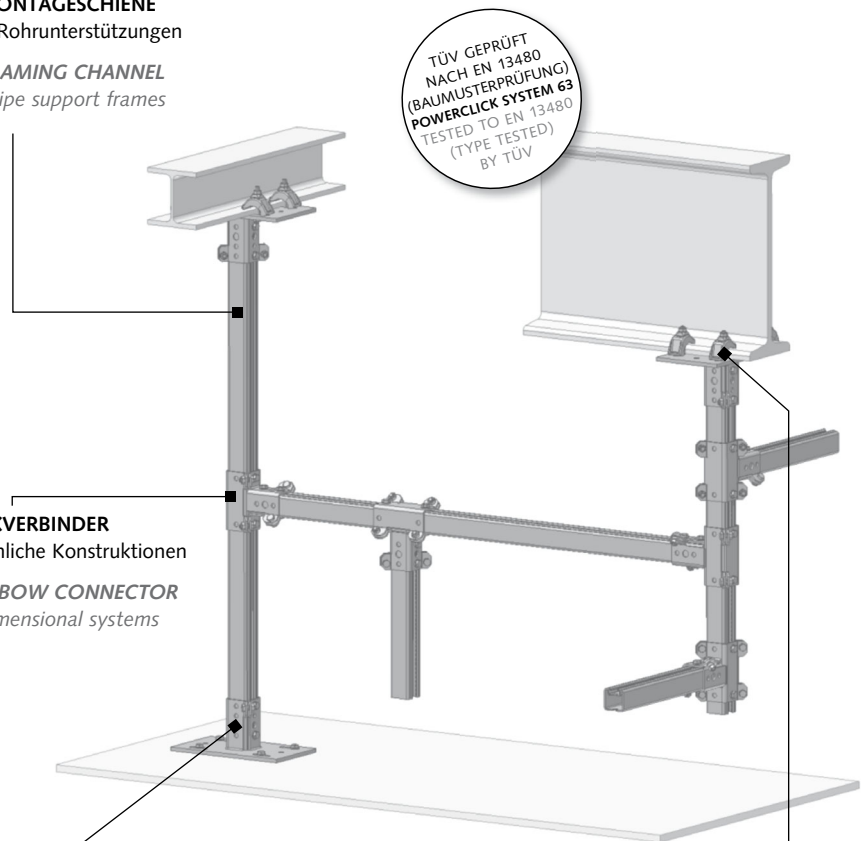

HALFEN POWERCLICK SYSTEM

Die Multifunktionalität auf einen Blick / *Multifunctionality at a glance*

Powerclick Montageschiene

Stark

Durch Formgebung und hohe Torsionssteifigkeit.

Sicher

Definierte Lastabtragung durch Formschluss.

Kompatibel

Uneingeschränkte Kompatibilität aller HALFEN Powerclick Systeme.

Justierbar

Anzuschließende Bauteile können an beliebiger Stelle der Schiene befestigt werden und bleiben justierbar.

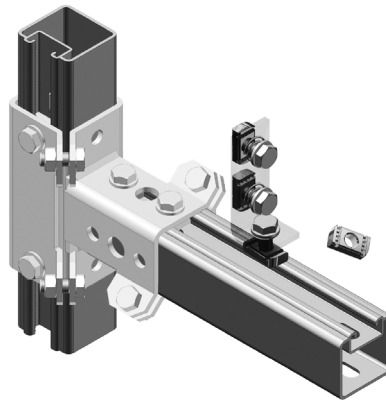

Powerclick profile

Strong

Closed section provides high torsional rigidity.

Safe

Defined load distribution by form-fit.

Compatible

Compatible with all HALFEN Powerclick systems.

Adjustable

Components can be fastened anywhere on the channel slot; all connections remain adjustable.

Powerclick Eckverbinder

Multifunktional

Rund um den Ausleger durch Umsetzen der Positionsschrauben. Rund um die Schiene durch Umsetzen der Positionsschrauben am Halter.

Einfache Montage

Aufstecken auf das Profil. Alternativ durch Entfernen der Spannschrauben die Schalen öffnen und um das Profil legen.

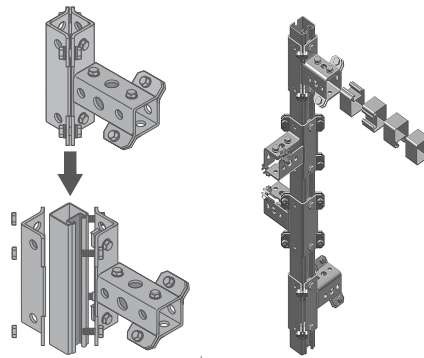

Powerclick elbow connector

Multifunktional

The channel is fixed horizontally with the slot facing up, down or to either side. Can also be installed in all directions around the vertical.

Simple assembly

Slide the connector over the channel end. Alternatively, remove the clamping bolts, open the bracket and replace around the channel in the desired position.

Powerclick Stützenfuß

Universell

Der Stützenfuß in drei Lieferausführungen passt für alle I Standardträger mit einer Flanscbreite von 75 – 300 mm.

Unabhängig

Die Richtung des Schienenschlitzes ist unabhängig von der Position des Fußes und lässt sich einfach an Halfenschienen und Stahlkonstruktionen anschrauben bzw. an Beton andübeln.

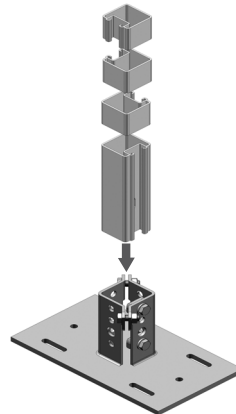

Powerclick base support

Universal

The base support, supplied in 3 sizes, fits all standard I beams with flange widths from 75 – 300 mm.

Independent

The base support can be fixed to both concrete and steel structures. The direction of the channel slot is independent of the position of the base support.

Powerclick Trägerklemme

Universell

Weiter Einstellbereich – eine einzige Trägerklemme für alle Standardträger.

Flexibel

Höhenverstellbar von 5 – 40 mm.

Sicher

Trägerklemme mit Biss, rutschsichere Lastabtragung durch vier Kerbzähne.

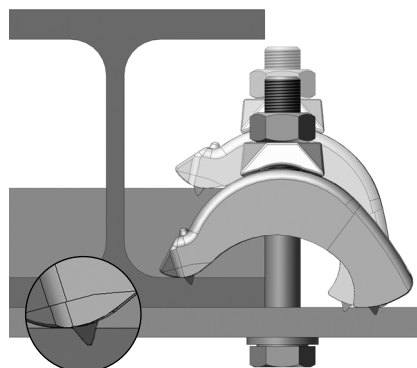

Powerclick beam clamp

Universal

Wide adjustment range—only one clamp for all standard beams.

Flexible

Height adjustable from 5 – 40 mm.

Safe

The beam clamps provide a mechanical connection at 4 points, and resistance to slip loads.

HALFEN POWERCLICK

Powerclick System 63



Bauteilanschlüsse

Connections to steel and concrete

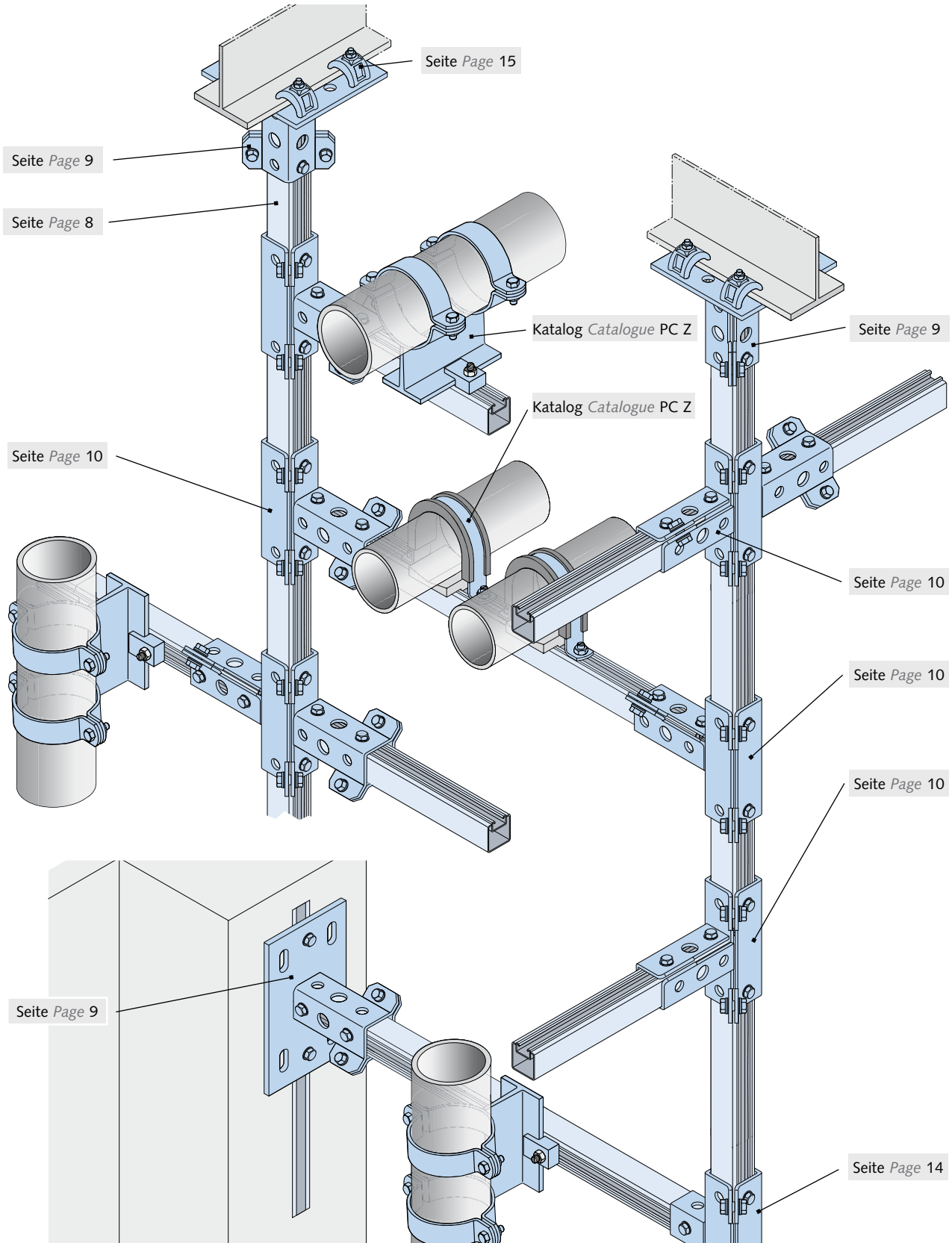

HALFEN POWERCLICK

Powerclick System 63



Bauteilanschlüsse

Structural connections

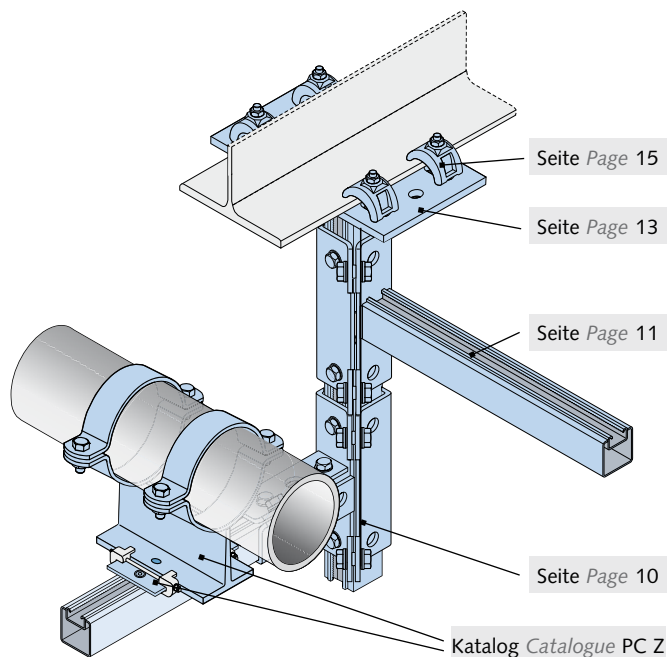
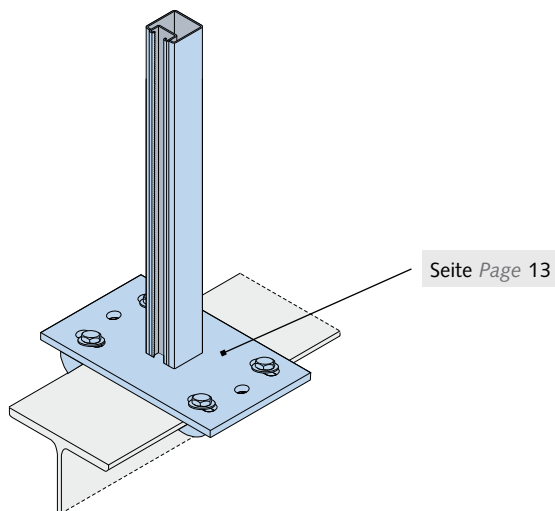
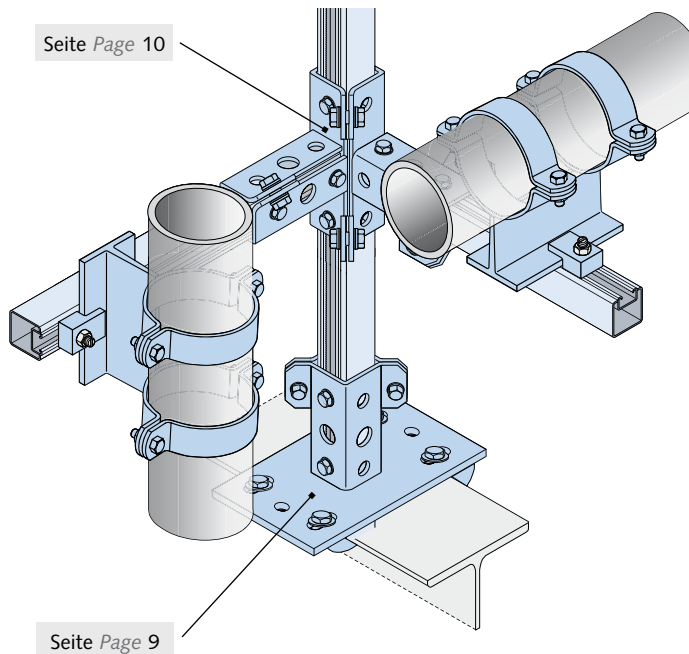
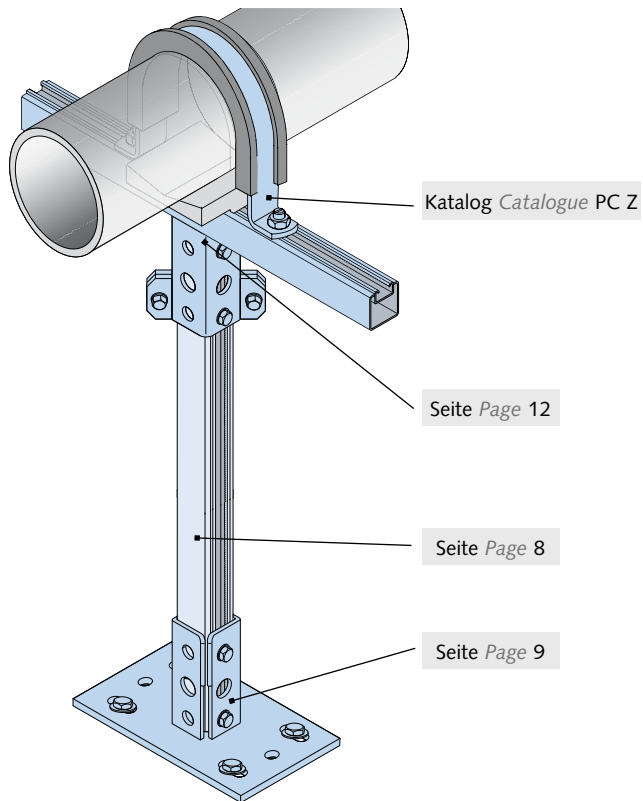

Werkstoff / Ausführung:

Material / Finish:

fv ①	S235JR feuerverzinkt (stückverzinkt)	S235JR hot-dip galvanized
①	- Verbindungsteil fv , Zinkauflage > 50 µm - Schraubverbindung fv , Zinkauflage > 45 µm - Profil fv , Zinkauflage > 50 µm	- connection part hdg , zinc coating > 50 µm - bolt connection hdg , zinc coating > 45 µm - channel hdg , zinc coating > 50 µm

Verfügbarkeit / Availability:

● = Standard/Off-the-shelf components

HALFEN POWERCLICK

Montageschienen Powerclick System 63 / Framing Channels Powerclick System 63



Profil HZL 63/63 - gezahnt, gelocht Channel HZL 63/63 - serrated, slotted

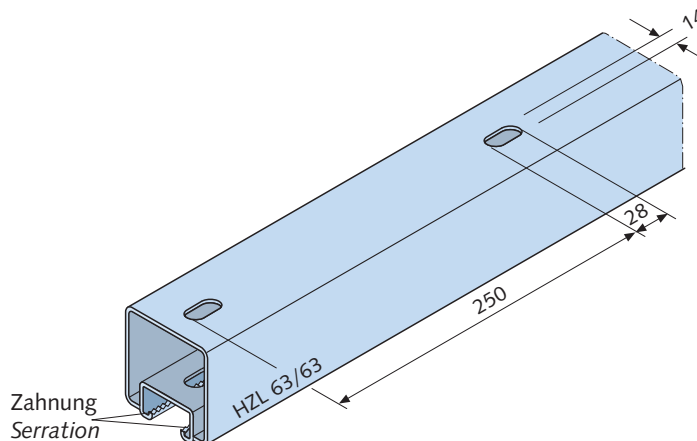
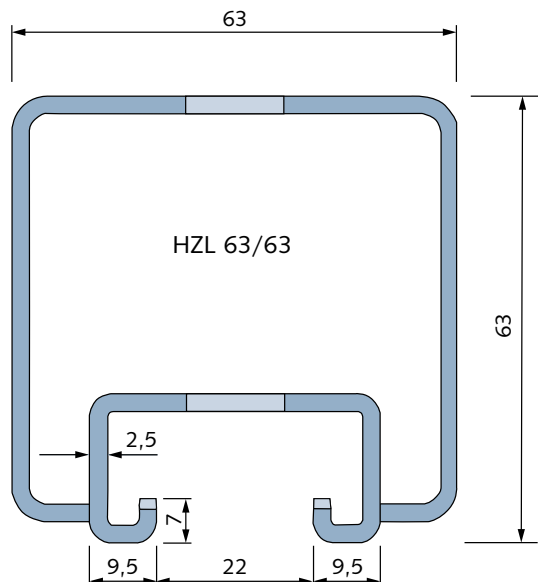

Das Profil ist durch formschlüssige Lastaufnahme für erhöhte Beanspruchung in Schienenlängsrichtung geeignet.
 Due to the serrated profile lips the channel resists loads in the longitudinal direction.

Nennmaße / Nominal dimensions [mm]

Produktdaten Product data

Profil Channel

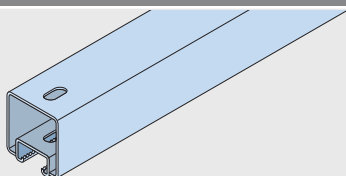

Materialausführung	Bestell-Nr.	Standard	Profilgewicht	Profilquerschnitt	Trägheitsmoment	Widerstandsmoment	Max. zul. Punkttragfähigkeit	Biegetragfähigkeit bei Spannweite L
Material, finish	Part no.	●	Channel weight	Cross section	Moment of inertia	Section modulus	Max. perm. point loading	Safe load at span L
	0283.030		G [kg/m]	A [cm ²]	I _y [cm ⁴] I _z [cm ⁴]	W _y [cm ³] W _z [cm ³]	F [kN] bei Stützweite L at span	0,50 1,00 1,50 F [kN] F [kN] F [kN]
fv ①	00001	●	6,35	7,09	33,07 42,95	10,06 13,63	4,2	11,1 5,6 3,7
fv ②	00003	●						

fv = feuerverzinkt fv = hot-dip galvanized

- ① Länge/length: 3000 mm
- ② Länge/length: 6000 mm

Bestellbeispiel: / Order example:

Bezeichnung / Description

HZL 63 / 63 - fv - 3000

oder Bestell-Nr. / or part no.

0283.030-00001

Zubehör Accessories

Profilendstopfen Channel end cap

Werkstoff: LDPE, blau, temperaturbeständig -40° - +110°C
 Material: LDPE, blue, temperature range -40° - +110°C

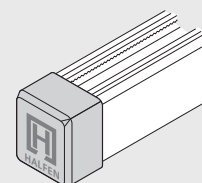

Bezeichnung Description	Bestell-Nr. Part no.	[Stck / Pcs.]
HPE 63/63	0318.000-00010	100 ●

Profilabdeckung Channel cover

Werkstoff: PVC hart, weiß, temperaturbeständig -40° - +110°C
 Material: plastic (PVC), white, temperature range -40° - +110°C

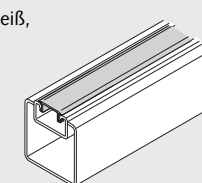

Bezeichnung Description	Bestell-Nr. Part no.	Lieferlänge Length [mm]
PA 41 - KS - 3000	0321.000-00002	3000 ●

HALFEN POWERCLICK

Verbindungsteile Powerclick System 63 / Fittings Powerclick System 63



Stützenfuß: Beton- und Trägeranschluss *Fixing plate: Connection to concrete and steel beam*

<p>Trägerflanschbreite: Beam flange width: 75 – 155 mm</p>	<p>Trägerflanschbreite: Beam flange width: 155 – 230 mm</p>	<p>Trägerflanschbreite: Beam flange width: 235 – 300 mm</p>
--	---	---

Bezeichnung Description	Bestell-Nr. Part no.		Bezeichnung Description	Bestell-Nr. Part no.		Bezeichnung Description	Bestell-Nr. Part no.	
HCS - VT 63 - 11/2 - fv	0300.020-00001	1	HCS - VT 63 - 12/2 - fv	0300.020-00002	1	HCS - VT 63 - 13/2 - fv	0300.020-00003	1
fv = feuerverzinkt	fv = hot-dip galvanized		fv = feuerverzinkt	fv = hot-dip galvanized		fv = feuerverzinkt	fv = hot-dip galvanized	

Anwendungsbeispiele: *Application examples:*

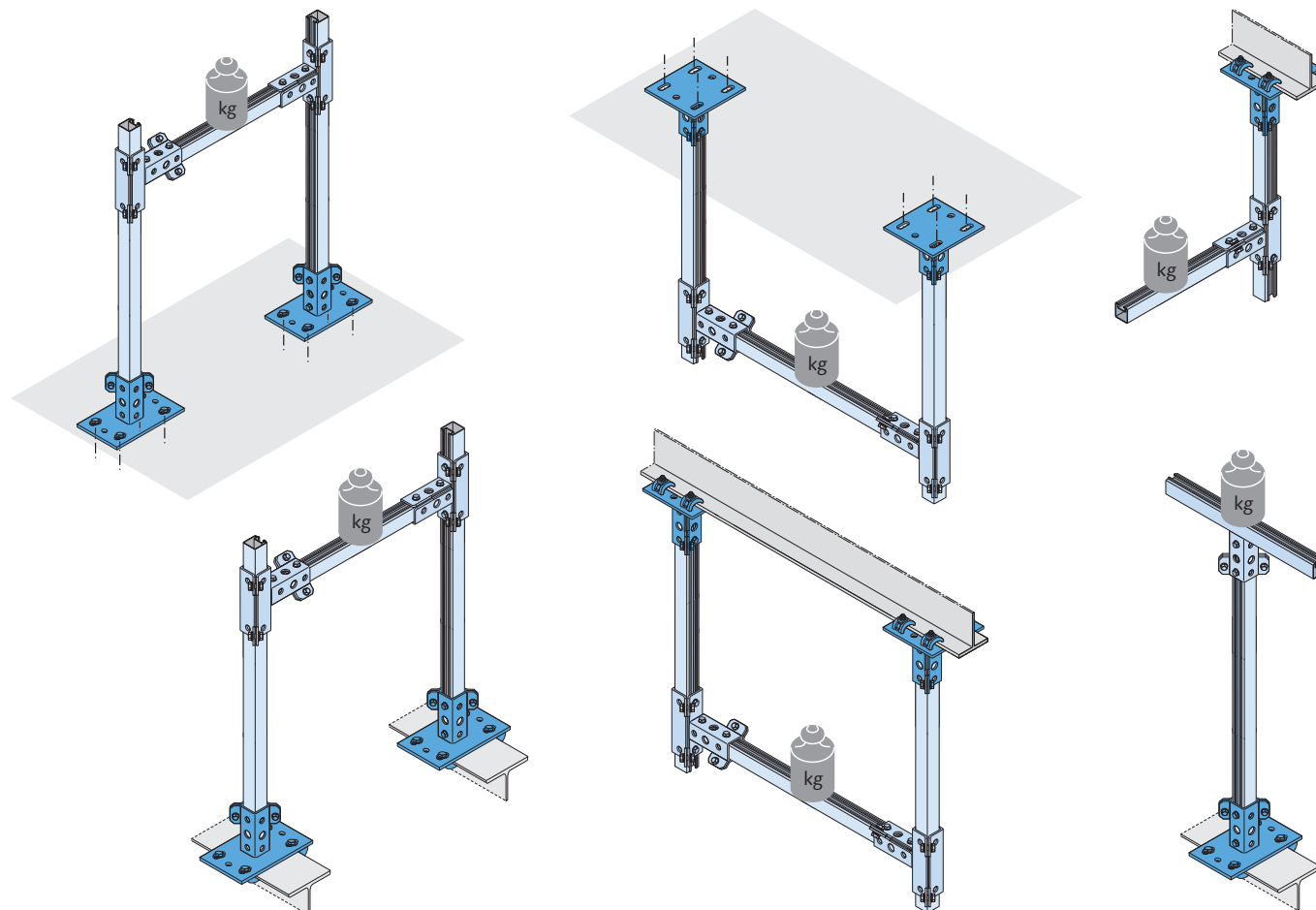

HALFEN POWERCLICK

Verbindungssteile Powerclick System 63 / Fittings Powerclick System 63



Eckverbinder: Montageschienenanschluss Connector: Connection to framing channel

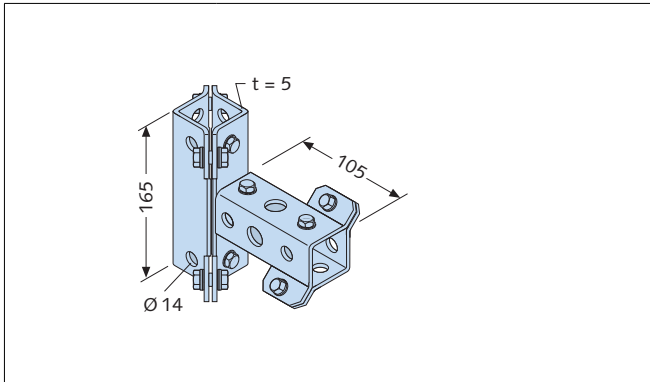

Bezeichnung Description	Bestell-Nr. Part no.		
HCS - VT 63 - 21/4 - fv	0300.020-00007	1	●
fv = feuerverzinkt fv = hot-dip galvanized			

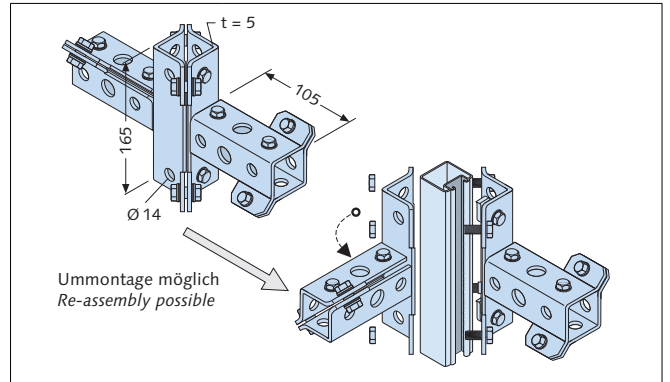

Bezeichnung Description	Bestell-Nr. Part no.		
HCS - VT 63 - 23/6 - fv	0300.020-00009	1	●
fv = feuerverzinkt fv = hot-dip galvanized			

Anwendungsbeispiele Application examples

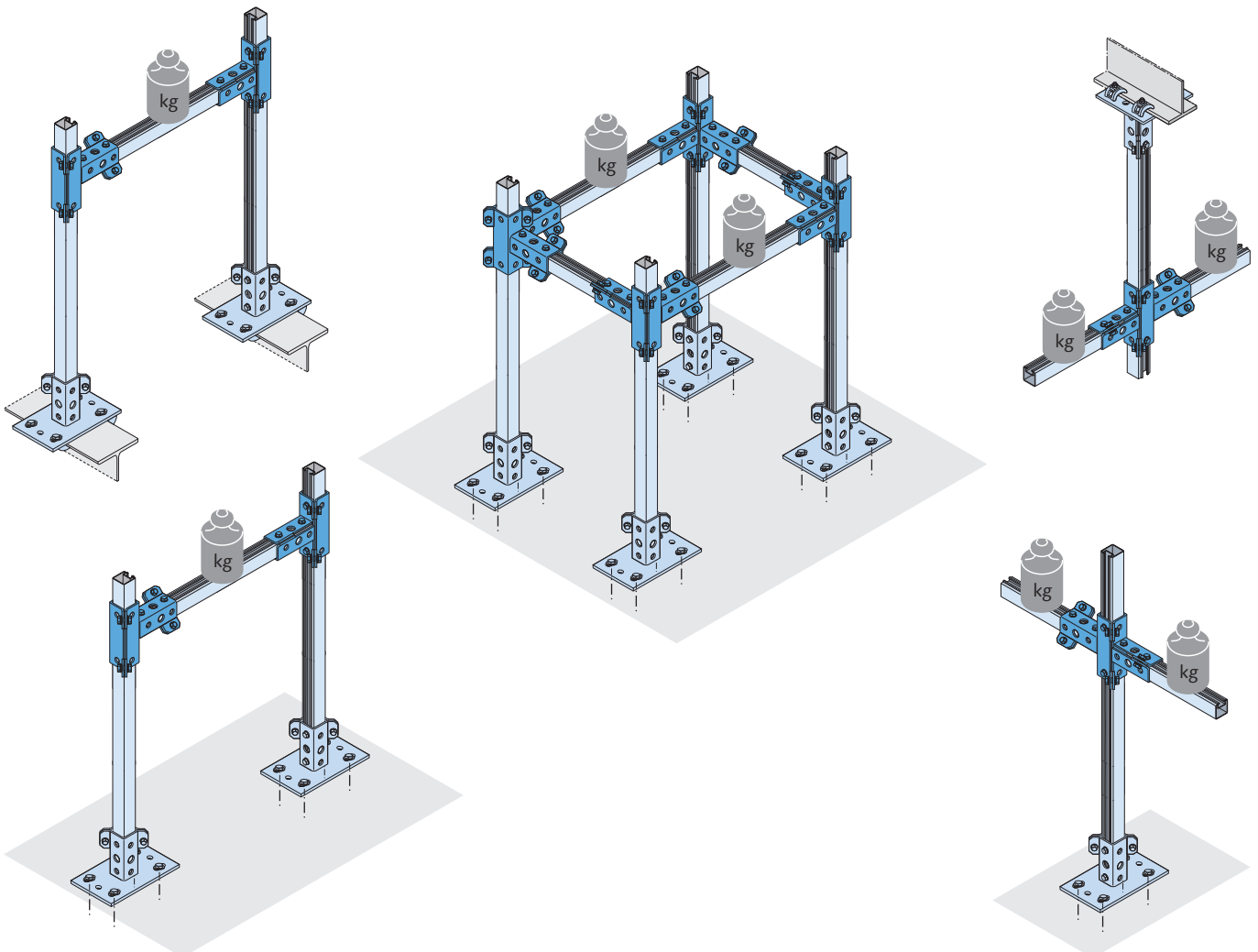

HALFEN POWERCLICK

Verbindungssteile Powerclick System 63 / Fittings Powerclick System 63



Systemkonsole: Montageschienenanschluss Cantilever Arm: Connection to framing channel

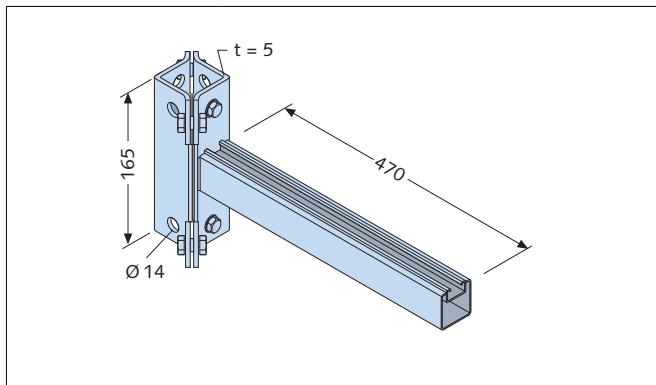

Bezeichnung Description	Bestell-Nr. Part no.		
HCS - VT 63 - 41/2 - fv	0300.020-00011	1	●
fv = feuerverzinkt fv = hot-dip galvanized			

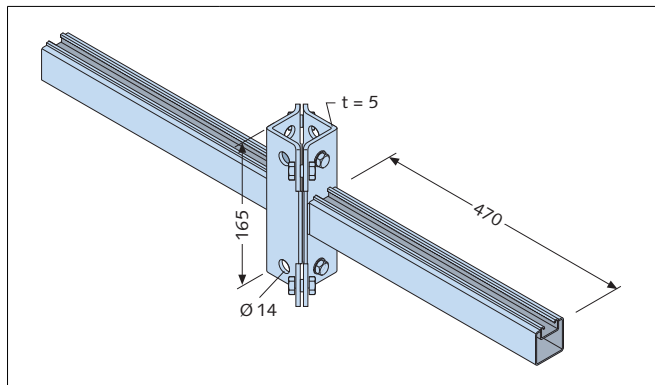

Bezeichnung Description	Bestell-Nr. Part no.		
HCS - VT 63 - 42/2 - fv	0300.020-00012	1	●
fv = feuerverzinkt fv = hot-dip galvanized			

Anwendungsbeispiele Application examples

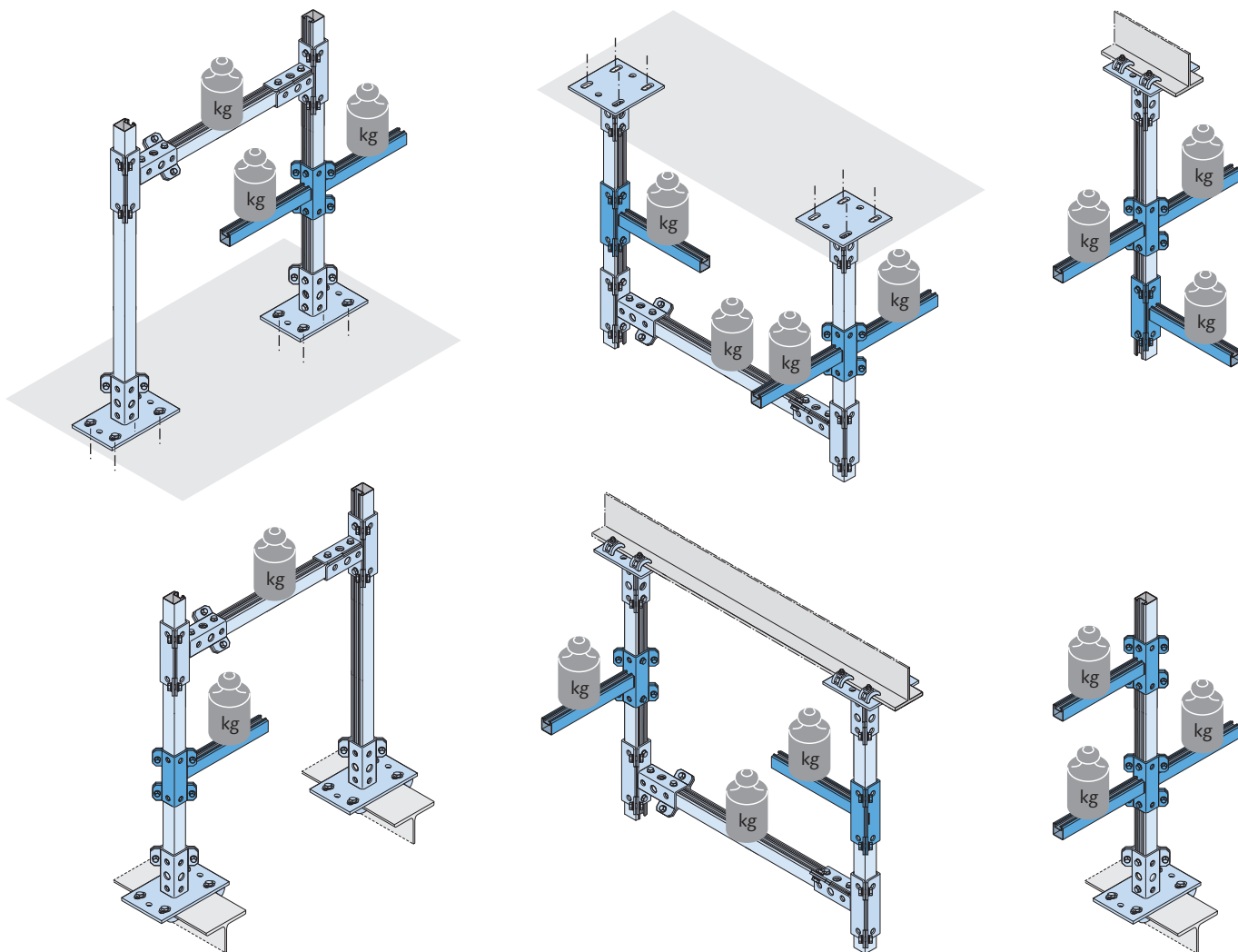

HALFEN POWERCLICK

Verbindungssteile Powerclick System 63 / Fittings Powerclick System 63



T-Verbinder: Montageschienenanschluss T-Connector: Connection to framing channel

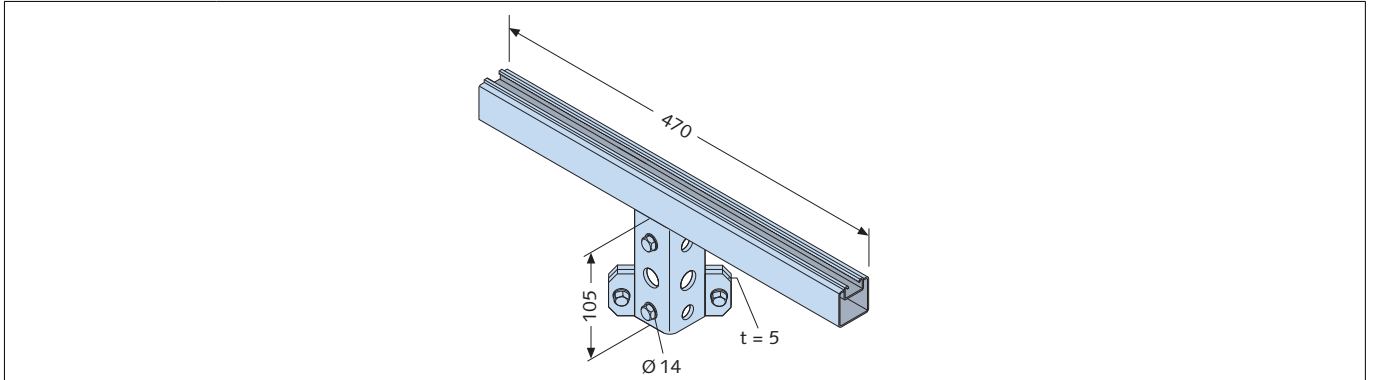

Bezeichnung Description	Bestell-Nr. Part no.		
HCS - VT 63 - 31/2 - fv	0300.020-00010	1	●
fv = feuerverzinkt fv = hot-dip galvanized			

Anwendungsbeispiele Application examples

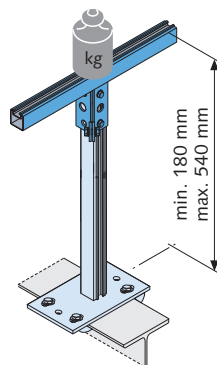
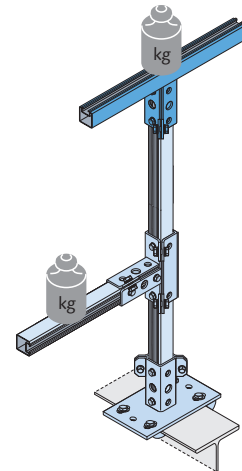
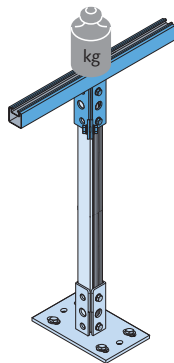

HALFEN POWERCLICK

Verbindungsteile Powerclick System 63 / Fittings Powerclick System 63



Stützenfuß: Beton- und Trägeranschluss *Fixing plate: Connection to concrete and steel beam*

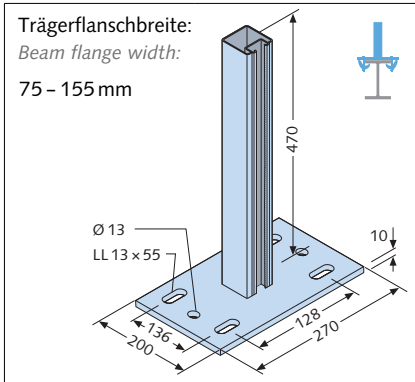

Bezeichnung Description	Bestell-Nr. Part no.	
HCS - VT 63 - 14/0 - fv	0300.020-00004	1
fv = feuerverzinkt <i>fv = hot-dip galvanized</i>		

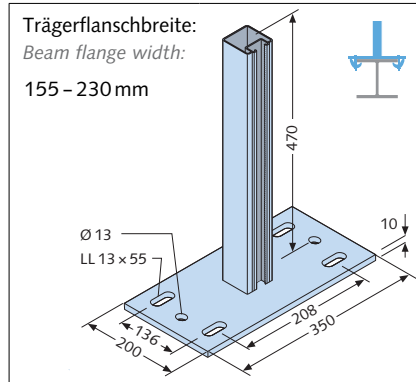

Bezeichnung Description	Bestell-Nr. Part no.	
HCS - VT 63 - 15/0 - fv	0300.020-00005	1
fv = feuerverzinkt <i>fv = hot-dip galvanized</i>		

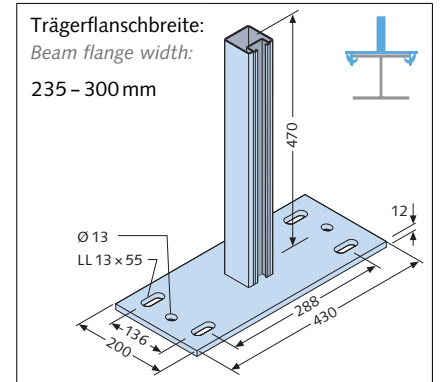

Bezeichnung Description	Bestell-Nr. Part no.	
HCS - VT 63 - 16/0 - fv	0300.020-00006	1
fv = feuerverzinkt <i>fv = hot-dip galvanized</i>		

Anwendungsbeispiele *Application examples*

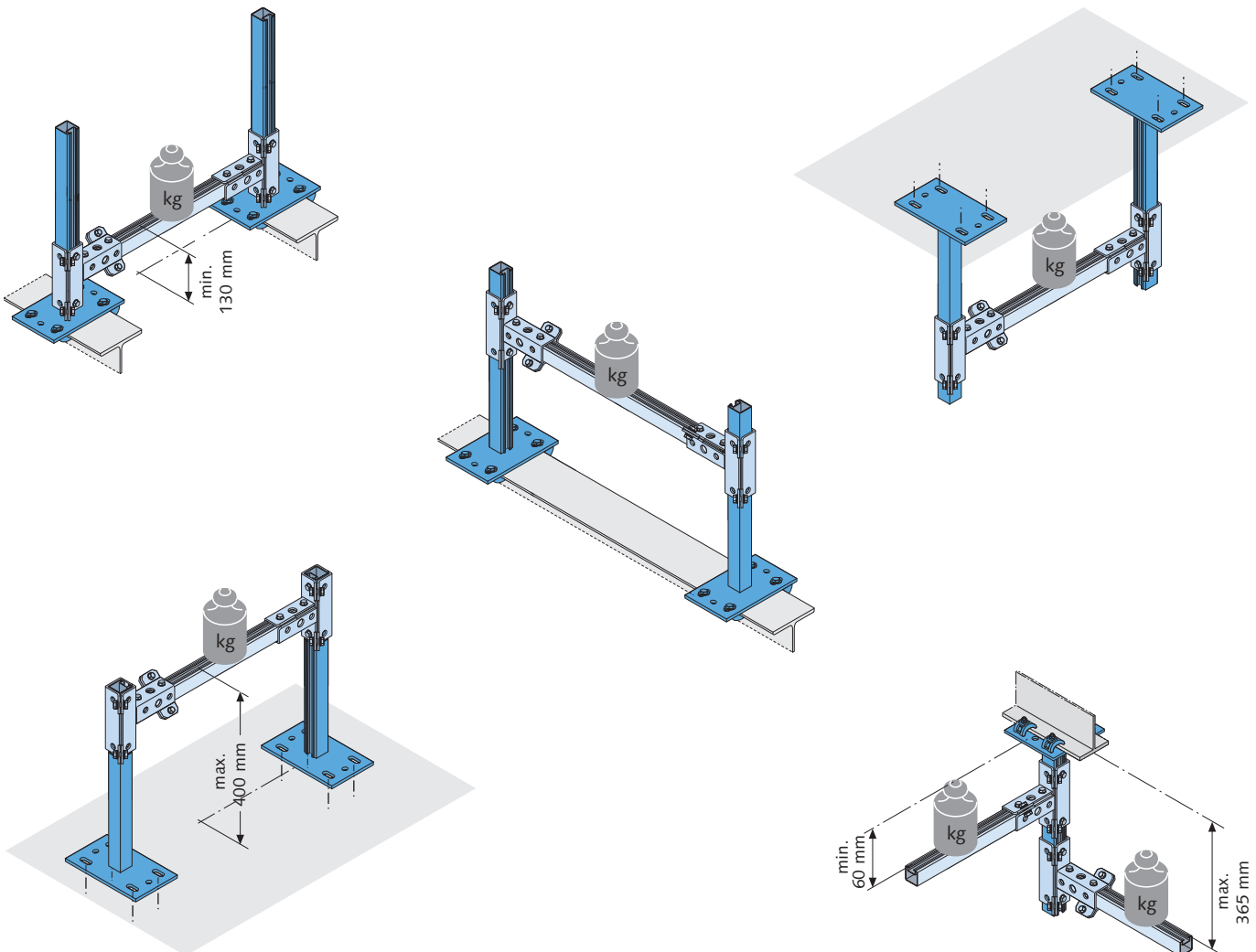

HALFEN POWERCLICK

Montageschienen Powerclick System 63 / Fittings Powerclick System 63



Eckverbinder: Montageschienenanschluss *Elbow connector: Connection to framing channel*

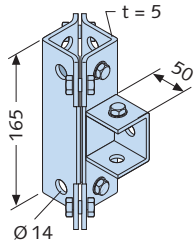

Eckverbinder Typ 22 nicht als Kragarmanschluss verwenden!

Do not use the elbow connector type 22 for cantilever arm connections!

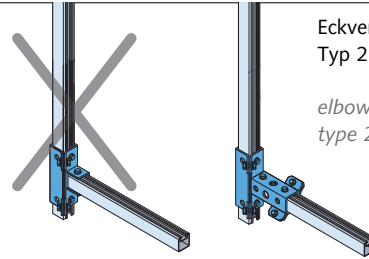

Eckverbinder Typ 21 → Seite 10

elbow connector type 21 → page 10

Bezeichnung <i>Description</i>	Bestell-Nr. <i>Part no.</i>		
HCS - VT 63 - 22/3 - fv	0300.020-00008	1	●

fv = feuerverzinkt *fv = hot-dip galvanized*

Anwendungsbeispiele *Application examples*

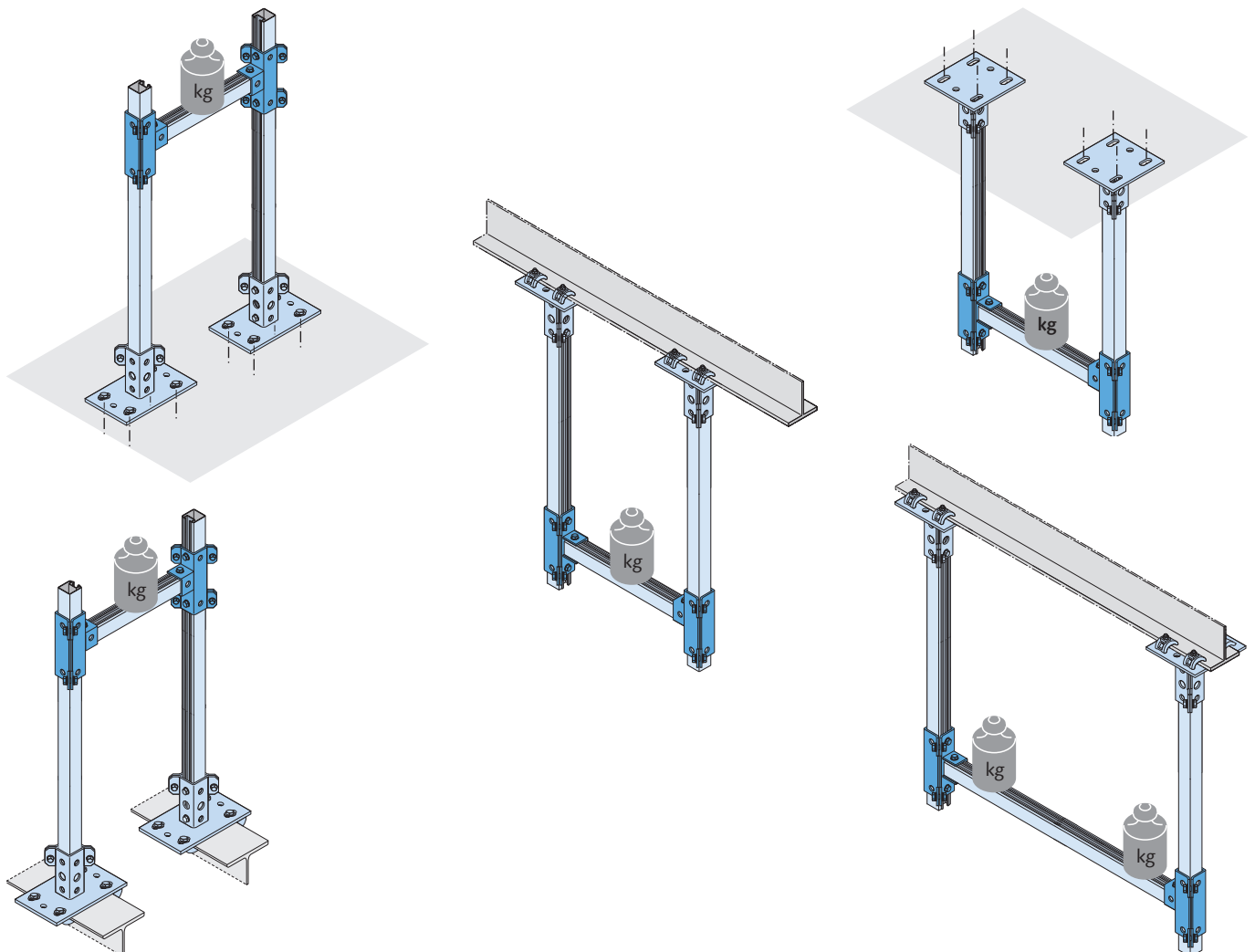

HALFEN POWERCLICK

Trägerklemmen Powerclick System 63 / Universal Beam Clamp Powerclick System 63



Trägerklemme: Trägeranschluss

Beam Clamp: Connection to steel beam

Trägerklemme mit „Biss“, 4 Spitzen zur formschlüssigen Lastübertragung

Beam clamp with 4 teeth for interlocking load transmission

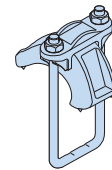
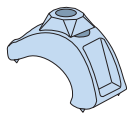
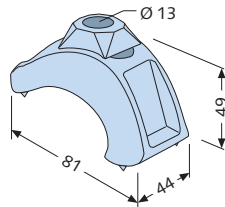

Bezeichnung Description	Bestell-Nr. Part no.		
HCS TK - fv	0308.030-00001	20	●
fv = feuerverzinkt	fv = hot-dip galvanized		

Bezeichnung Description	Bestell-Nr. Part no.		
HCS TK - L - fv	0308.030-00002	20	●
fv = feuerverzinkt	fv = hot-dip galvanized		

Bezeichnung Description	Bestell-Nr. Part no.		
HCS TK - 63 - fv	0308.030-00003	10	●
fv = feuerverzinkt	fv = hot-dip galvanized		

Anwendungsbeispiele

Application examples

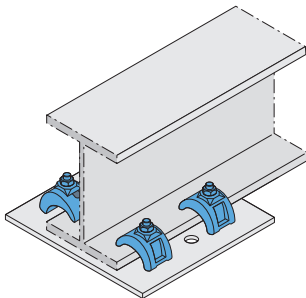

Allgemeine Trägeranbindung außerhalb der Systemanwendung

Application for general fixing to steel beams other than system applications



Anzugsdrehmoment abhängig von der Schraube
Tightening torque depends on bolt

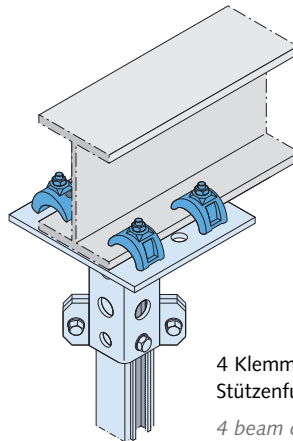

4 Klemmen pro Stützenfuß

4 beam clamps are used to fix the base plate to steel beams



Anzugsdrehmoment 90 Nm
Tightening torque 90 Nm

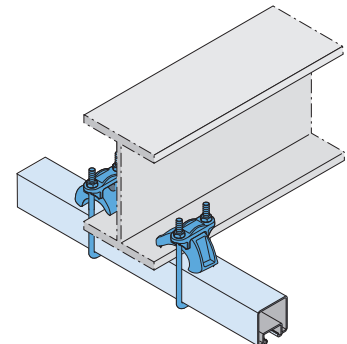

Einsatz paarweise

Beam clamps used in pairs to fix channel directly to steel beams



Anzugsdrehmoment 45 Nm
Tightening torque 45 Nm

Montagehinweis: Assembly note:

h = 5-40mm Flanschdicke Flange thickness

L \geq Trägerflanschbreite + (2 \times 90mm)
 \geq Beam flange width + (2 \times 90mm)

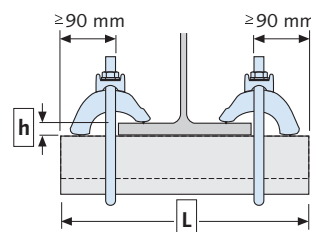



EN 13480

Für Druckgeräte ist die EU-Richtlinie 2014/68/EU des Europäischen Parlamentes rechtsverbindlich. In der gesamten Europäischen Union gelten zwingend die grundlegenden Sicherheitsanforderungen dieser Richtlinie. Die EN 13480 „Metallische Industrielle Rohrleitungen“ ist z. Zt. die einzige zu dieser grundlegenden Richtlinie harmonisierte Produktnorm für Rohrleitungen und deren Halterungen.

In den nachfolgenden Tabellen werden Tragfähigkeitswerte nach Rohrleitungsnorm EN 13480 für normale Betriebsbedingungen („Nennlasten“ - N) angegeben. Die gelegentlichen Betriebsbedingungen sind gemäß EN 13480-3 anzunehmen. Durch Baumusterprüfung nach EN 13480-3 Anhang J wurden für normale Betriebsbedingungen „Nennlasten“ ermittelt, die Sicherheitsfaktoren von 1,6 zum Fließen und 4,0 zum Bruch enthalten.
(Tabellen der Seiten 17 bis 19)

Anwendung nach EN 1993-1 (EC3)

Die Tragfähigkeitsangaben für allgemeine Stahlbauanwendung beruhen auf Auswertung der für das Powerclick System 63 durchgeführten Versuche mit den im Stahlbau üblichen Sicherheiten und ergänzender Rahmenstatik nach den Regeln der EN 1993-1 (EC3).
(Tabellen der Seiten 20 und 21)

EN 13480

The EU Guidelines for pressure equipment 2014/68/EU issued by the European Parliament are mandatory. The fundamental safety requirements of this Directive are compulsory throughout the European Union. At present, EN 13480 "Metallic industrial piping" is the only harmonised standard relating to the elementary guidelines for pipe systems and their supporting structures.

The following tables contain bearing values according to the rules for piping EN 13480 for normal operating conditions ("allowable loads" - N). Load bearing values for occasional operating conditions shall be taken in accordance with the standard EN 13480-3. For normal operating conditions, "allowable loads" had been determined by type testing in accordance with EN 13480-3 annex J. These "allowable loads" include safety factors of 1.6 for yield and 4.0 for ultimate failure.
(tables on pages 17 to 19)

Application acc. to EN 1993-1 (EC3)

The bearing values for general steel construction applications are based on evaluation of the type tests, which were implemented with the Powerclick System 63, in relation with the usual safety factors of general steel construction and complementary frame analysis according to EN 1993-1 (EC3).
(tables on pages 20 and 21)

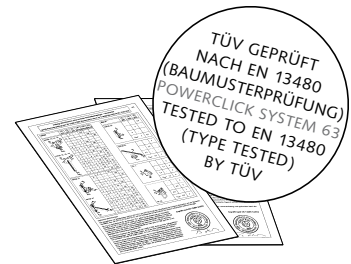

Das Dokument der Baumusterprüfung senden wir Ihnen auf Anfrage gerne zu.

The Type Test document is available on request.

Anzugsdrehmomente Torque

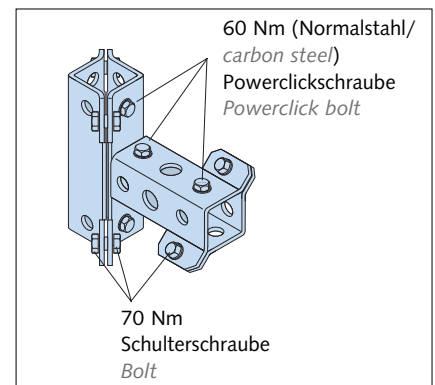

HALFEN POWERCLICK

Bemessung nach **EN 13480-3** / Design acc.to **EN 13480-3**

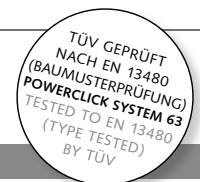

Zulässige Lasten für Verbindungsteile *Allowable loads for connection parts*

Normale Betriebsbedingungen „Nennlasten“
Normal operating conditions "allowable loads"

	$\pm Q_x$	$\pm Q_y$	$\pm N_z$	$\pm M_x$	$\pm M_y$	$\pm M_{zt}$
	[kN]	[kN]	[kN]	[kNcm]	[kNcm]	[kNcm]
Typ: Type: HCS-VT63-11,-12,-13 	-	6	-	105	-	-
	6	-	-	-	105	-
	-	-	-	-	-	85
	-	-	7	-	-	-
	-	5	7	100	-	-
	5	-	7	-	100	-
	5	2	6	90	-	-
	2	5	6	-	90	-
Typ: Type: HCS-VT63-14,-15,-16 	-	3	6	85	-	30
	3	-	6	-	85	30
	3	3	6	55	-	30
	3	3	6	-	55	30
	2,5	2,5	6	50	50	-
	2	2	6	30	50	30
	2	2	6	50	30	30
	-	3	7	55	-	50
Typ: Type: HCS-VT63-21 	-	6	-	55	-	-
	6	-	-	-	105	-
	-	-	-	-	-	85
	-	-	7	-	-	-
	-	5	7	50	-	-
	5	-	7	-	100	-
	2	5	6	45	-	-
	5	2	6	-	90	-
-	3	6	40	-	40	
Typ: Type: HCS-VT63-41 	3	-	6	-	75	40
	3	3	6	30	-	30
	3	3	6	-	55	30
	2,5	2,5	6	25	50	-
	2	2	6	15	50	30
	2	2	6	30	20	30
	-	2,5	7	40	-	40
	3	-	7	-	55	50

Normale Betriebsbedingungen „Nennlasten“
Normal operating conditions "allowable loads"

	$\pm Q_x$	$\pm Q_y$	$\pm N_z$	
	[kN]	[kN]	[kN]	
Typ: Type: HCS-VT63-22 	-	-	4,5	
	-	4	-	
	4	-	-	
	Q _{Res} =	4	4,5	
	Typ: Type: HCS-VT63-31 	-	-	7
		-	2,5	-
2,5		-	-	
Q _{Res} =		2,5	7	
Typ: Type: HCS TK-L 		-	-	6
	-	1,2	4	
	1,2	-	4	
	Q _{Res} =	1,2	4	
	Typ: Type: HCS TK 63 	-	-	5
-		0,9	3	
0,9		-	3	
Q _{Res} =		0,9	3	

Die Befestigung mittels Dübel und Klemmen muss bauseits nachgewiesen werden.
Fixings using site drilled bolts and clamps must be site tested.

Im Falle „gelegentlicher Betriebsbedingungen“ dürfen die „Nennlasten“ gemäß EN 13480-3, Anhang J erhöht werden.
For "occasional operating conditions" the allowable loads can be increased acc. to EN 13480-3, annex J.

HALFEN POWERCLICK

Bemessung nach EN 13480-3 / Design acc. to EN 13480-3

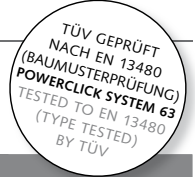

Zul. Lasten max. F_Z für Rahmenkonstruktionen Allowable loads max. F_Z for framework

Tabellenwerte gültig für Verbindungsteile gemäß Seiten 9, 10 und 13

Table values are valid for fittings according to pages 9, 10 and 13

		Normale Betriebsbedingungen „Nennlasten“ Normal operating conditions "allowable loads" Zulässige Last max. F _Z [kN] bei Stablänge L [mm] Allowable load max. F _Z [kN] for channel length L [mm]	Profil: Channel: HSL 63/63						
			L = 600 F _Z [kN]	L = 800 F _Z [kN]	L = 1000 F _Z [kN]	L = 1200 F _Z [kN]	L = 1400 F _Z [kN]	L = 1600 F _Z [kN]	L = 1800 F _Z [kN]
	1500	9,3	7,0	5,6	4,7	4,0	3,5	3,1	
	1000	6,6	5,7	4,6	3,8	3,3	2,9	2,5	
	1500	4,4	4,4	4,4	3,8	3,3	2,9	2,5	
	1500	6,0	5,2	4,2	3,5	3,0	2,6	2,3	
	1000	3,3	3,3	3,3	2,8	2,4	2,1	1,9	
	1500	2,2	2,2	2,2	2,2	2,2	2,1	1,9	
	1500	4,0	3,5	2,8	2,3	2,0	1,7	1,5	
	1000	2,2	2,2	2,2	1,9	1,6	1,4	1,2	
	1500	1,5	1,5	1,5	1,5	1,5	1,4	1,2	
	1500	3,0	2,9	2,3	1,9	1,6	1,4	1,3	
	1000	1,7	1,7	1,7	1,6	1,3	1,2	1,0	
	1500	1,1	1,1	1,1	1,1	1,1	1,1	1,0	
	1500	2,4	2,3	1,8	1,5	1,3	1,1	1,0	
	1000	1,3	1,3	1,3	1,2	1,1	0,9	0,8	
	1500	0,9	0,9	0,9	0,9	0,9	0,9	0,8	

Erläuterungen:
 Explanations:

max F_Z = Einzelkraft pro Lasteinleitung (z.B. Leitungen ohne Dehnung)
 = point load without lateral forces (e.g. pipes without expansion)

max F_Z = aus Überlagerung / Superposition F_X oder/oder F_Y = 0,3 × max. F_Z (z.B. Leitungen mit Dehnung)
 = point load with lateral forces (e.g. pipes with expansion)

Die Befestigung mittels Dübel und Klemmen (Flanschbreite < 150 mm) muss bauseits nachgewiesen werden.
 Fixings using site drilled bolts and clamps (flange width < 150 mm) must be site tested.

Im Falle „gelegentlicher Betriebsbedingungen“ dürfen die „Nennlasten“ gemäß EN 13480-3, Anhang J erhöht werden.
 In case of "occasional operating conditions" the allowable loads can be increased acc. to EN 13480-3, annex J.

HALFEN POWERCLICK

Bemessung nach EN 13480 / Design acc.to EN 13480

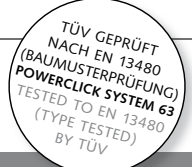

Zul. Lasten F_z für Kragarmkonstruktionen Allowable loads F_z for cantilever arm structures

	L [mm]	Normale Betriebsbedingungen „Nennlasten“ Normal operating conditions "allowable loads"			Profil: Channel: HSL 63/63
		H [mm]	H = 500 F_z [kN]	H = 1000 F_z [kN]	
	300	3,0	3,0	2,6	Verbindungsteile: Fixing elements:
	500	1,8	1,8	1,7	
	300	1,8	1,6	1,3	
	500	1,3	1,2	1,0	

Max. mittige Einzellast max. F_z für freistehende Unterstützung Max. centred single load max. F_z for freestanding supports

	Normale Betriebsbedingungen „Nennlasten“ Normal operating conditions "allowable loads"			Profil: Channel: HSL 63/63
	H [mm]	H = 500 F_z [kN]	H = 1000 F_z [kN]	
	Außermittige Lasteinleitung ± 50 mm Loads ± 50 mm eccentricity			Verbindungsteile: Fixing elements:
	7,0	7,0	7,0	
	Außermittige Lasteinleitung ± 50 mm Loads ± 50 mm eccentricity			
	5,2	3,0	2,1	

Knicknachweis *Buckling proof*

Profil HSL 63/63 als Druckstab Channel HSL 63/63 as compression element (or column)	Normale Betriebsbedingungen „Nennlasten“ Normal operating conditions "allowable loads"										Profil: Channel: HSL 63/63	
	A	e	I_y	W_y	W_{ply}	$i_{y \min}$	H = 500	H = 1000	H = 1500	H = 2000		H = 2500
	[cm ²]	[cm]	[cm ⁴]	[cm ³]	[cm ³]	[cm]	F [kN]	F [kN]	F [kN]	F [kN]	F [kN]	F [kN]
	7,09	3,01	33,07	10,06	13,51	2,16	13,8	13,6	13,4	13,2	12,5	10,4

- ③ F = zulässige Betriebslast, $E = 210000 \text{ N/mm}^2$.
Hinweis: Bei größerer Außermittigkeit ist die zulässige Last gemäß Knicknachweis nach EN 13480 zu berechnen.
- ③ F = Allowable load, $E = 210000 \text{ N/mm}^2$.
Note: When greater eccentricity occurs, the max. load should be calculated in terms of buckling in accordance with EN 13480.

Erläuterungen: Explanations: 	= Einzelkraft pro Lasteinleitung (z.B. Leitungen ohne Dehnung) = point load without lateral forces (e.g. pipes without expansion)	= aus Überlagerung / Superposition F_x oder/oder $F_y = 0,3 \times \text{max. } F_z$ (z.B. Leitungen mit Dehnung) = point load with lateral forces (e.g. pipes with expansion)	Die Befestigung mittels Dübel und Klemmen (Flanschbreite < 150 mm) muss bauseits nachgewiesen werden. Fixings using site drilled bolts and clamps (flange width < 150 mm) must be site tested.	Im Falle „gelegentlicher Betriebsbedingungen“ dürfen die „Nennlasten“ gemäß EN 13480-3, Anhang J erhöht werden. In case of "occasional operating conditions" the allowable loads can be increased acc. to EN 13480-3, annex J.
---	--	---	---	---

HALFEN POWERCLICK

NEU! Bemessung nach EN 1993-1 (EC3) / NEW! Design acc. to EN 1993-1 (EC3)



Zulässige Lasten gemäß Standard-Einbausituation (Lage Schienenschlitz gem. Abb.)

Allowable loads for standard installation situation (Position channel slot acc. to figure)

F_z max für Rahmenkonstruktionen		Allowable loads max. F_z for framework							
			Tabellenwerte gültig für Verbindungsteile gemäß Seiten 9, 10 und 13 Table values are valid for fittings according to pages 9, 10 and 13						
			Profil: Channel: HSL 63/63						
			F_z max [kN] bei Stablänge L [mm] Allowable load F_{zmax} [kN] for channel length L [mm]						
	max. H [mm]		L = 600 Fz [kN]	L = 800 Fz [kN]	L = 1000 Fz [kN]	L = 1200 Fz [kN]	L = 1400 Fz [kN]	L = 1600 Fz [kN]	L = 1800 Fz [kN]
	1500	max F_z	17,50	13,70	11,45	9,80	8,60	7,70	7,00
	1000	max F_z	11,40	10,40	8,60	7,35	6,45	5,70	5,10
	1500	max F_z	7,70	7,70	7,25	7,00	6,00	5,30	4,90
	1000	max F_z	10,00	10,00	9,80	8,60	7,70	7,00	6,35
	1500	max F_z	5,70	5,50	5,20	4,90	4,70	4,50	4,30
	1000	max F_z	3,90	3,90	3,65	3,55	3,50	3,40	3,20
	1500	max F_z	6,70	6,60	6,35	5,50	4,90	4,40	4,00
	1000	max F_z	3,80	3,70	3,50	3,35	3,20	3,00	2,80
	1500	max F_z	2,60	2,60	2,45	2,35	2,35	2,30	2,15
	1000	max F_z	5,00	5,00	5,00	4,80	4,25	3,85	3,50
	1500	max F_z	2,90	2,75	2,65	2,55	2,40	2,30	2,20
	1000	max F_z	1,90	1,90	1,80	1,75	1,75	1,70	1,65
	1500	max F_z	4,00	4,00	4,00	3,75	3,30	3,00	2,75
	1000	max F_z	2,35	2,25	2,15	2,05	1,95	1,85	1,80
	1500	max F_z	1,50	1,50	1,45	1,40	1,40	1,40	1,30
	1000	max F_z							

$$F_{z,Rd} = 1,4 \times F_z$$

Erläuterungen:
Explanations:



= Einzelkraft pro Lasteinleitung
(z.B. Leitungen ohne Dehnung)
= point load without lateral forces
(e.g. pipes without expansion)

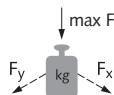

= aus Überlagerung / Superposition
 F_x oder/oder $F_y = 0,3 \times \text{max. } F_z$
(z.B. Leitungen mit Dehnung)
Point loads with lateral forces
(e.g. pipes with expansion)

Die Befestigung mittels Dübel und Klemmen muss separat nachgewiesen werden.

Fixings using site drilled bolts and clamps must be calculated separately. Bei Anbindung mittels Trägerklemmen sind die Klemmkraft am Berührungspunkt zwischen Klemme und Tragwerk wirkend anzunehmen und mit den entsprechenden zul. Betriebslasten zu vergleichen.

With connections using beam clamps the point of load assumption is the point of contact between the clamp and the support structure, these clamping forces are compared with the corresponding max. allowable service loads.

Bei geklemmtem Anschluss und horizontalen Lasten F_x , F_y sind die Tabellenwerte teilweise zu reduzieren.

The values in the table may be partially reduced for clamped connections and horizontal loads F_x , F_y .

HALFEN POWERCLICK

NEU! Bemessung nach EN 1993-1 (EC3) / NEW! Design acc. to EN 1993-1 (EC3)



Zulässige Lasten gemäß Standard-Einbausituation (Lage Schienenschlitz gem. Abb.)

Allowable loads for standard installation situation (Position channel slot acc. to figure)

Zul. Betriebslasten max. F_z für Kragarmkonstruktionen		Allowable loads max. F_z for Cantilever arm structures			Profil: Channel: HZL 63/63	Verbindungsteile: Fixing elements:
	L [mm]	Zul. Last max. F_z [kN] bei Stablänge H [mm]: Allowable load max. F_z [kN] for channel length H [mm]:				
		H = 500 F_z [kN]	H = 1000 F_z [kN]	H = 1500 F_z [kN]		
	300	5,9	3,9	2,8		
	500	2,7	2,0	1,5		
	300	3,3	2,4	1,4		
	500	2,2	1,5	1,0		

Max. mittige Einzellast max. F_z für freistehende Unterstützung		Max. centred single load max. F_z for freestanding supports			Profil: Channel: HZL 63/63	Verbindungsteile: Fixing elements:
	H [mm]	Zul. Last max. F_z [kN] bei Stablänge H [mm]: Allowable load max. F_z [kN] for channel length H [mm]:				
		H = 500 F_z [kN]	H = 1000 F_z [kN]	H = 1500 F_z [kN]		
	300	10,0	10,0	10,0		
	500	8,3	4,8	2,6		

Knicknachweis <i>Buckling proof</i>		Zul. Last F [kN] bei Stablänge H [mm]: Allowable load F [kN] for channel length H [mm]:						Profil: Channel: HZL 63/63					
Profil HZL 63/63 als Druckstab Channel HZL 63/63 as compression element		A [cm ²]	e [cm ²]	I_y [cm ²]	W_y [cm ²]	W_{ply} [cm ²]	i_y min [cm ²]		H = 500 F [kN]	H = 1000 F [kN]	H = 1500 F [kN]	H = 2000 F [kN]	H = 2500 F [kN]
		7,09	3,01	33,07	10,06	13,51	2,16	46,4	38,0	30,9	25,3	21,2	17,7

③ F = zulässige Last, $E = 210000 \text{ N/mm}^2$.

Hinweis: Bei größerer Außerzmittigkeit ist die zulässige Last gemäß Knicknachweis nach DIN EN 1993 (EC3) zu berechnen.

③ F = Allowable load, $E = 210000 \text{ N/mm}^2$.

Note: If eccentricity is greater than 5 cm, the max. allowed load must be recalculated for buckling acc. to DIN 1993 (EC3)

<p>Erläuterungen: Explanations:</p> <p>= Einzelkraft pro Lasteinleitung (z.B. Leitungen ohne Dehnung) = point load without lateral forces (e.g. pipes without expansion)</p>	<p>Die Befestigung mittels Dübel und Klemmen muss bauseits nachgewiesen werden. Fixings using site drilled bolts and clamps must be site tested.</p>
<p>= aus Überlagerung / Superposition F_x oder/oder $F_y = 0,3 \times \text{max. } F_z$ (z.B. Leitungen mit Dehnung) Point loads with lateral forces (e.g. pipes with expansion)</p>	

HALFEN POWERCLICK

Das Powerclick-Service-Paket / *The Powerclick System Service*

Internet CAD Bibliotheken *Internet CAD libraries*

Die CADENAS Bauteilbibliotheken mit dem PARTcommunity 3D CAD Katalog: nach einer kurzen Registrierung - kostenlos!

Sicher ist auch Ihr benötigtes Format vorhanden. Die Bibliotheken werden kontinuierlich ergänzt.

Bitte besuchen Sie uns auf:

→ halfen.partcommunity.com.

The CADENAS CAD libraries and PART-community 3D Catalogues:

Complimentary—after registration!

If the format you need isn't listed then find it at

→ halfen.partcommunity.com.

The library is continually being updated.

Verfügbare 2D-Formate / *Available 2D file formats:*

Allplan 2008, Catia V4, DWG ≥ AutoCad® 2004, DXF AutoCAD® ≥ 2004, Microstation ≥ V8 ...

Verfügbare 3D-Formate / *Available 3D file formats:*

Allplan 2008, AutoCAD® ≥ 2014, Autodesk® Revit ≥ 2012, Aveva PDMS/Marine, Catia ≥ V5, IGES, STEP, IFC 2x3, Inventor ≥ 2011, Microstation 3D, Solid Edge ≥ ST2, Solid Works ≥ 2006, Sketchup...

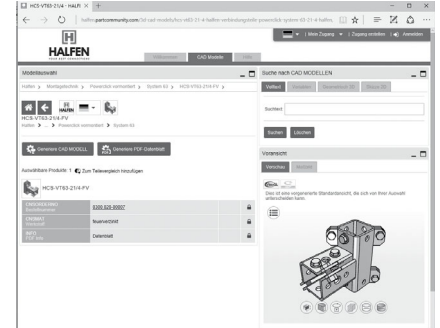

Screenshot: Modellauswahl mit interaktiver 3D-Darstellung

Screenshot: Product selection with interactive 3D model

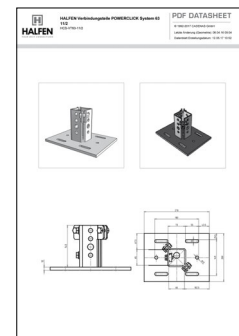

Screenshot: PDF Datenblatt zum Download
Screenshot: Downloadable PDF Datasheet



2D CAD DWG und DXF Formate, mit Rahmen, Stützen und Kragarmen als Komplettkonstruktionen, finden Sie auch im Download unter → www.halfen.com

2D DWG and DXF file formats with frames, columns and cantilevers as complete structural elements are also available at → www.halfen.com

Auf Anfrage/on request

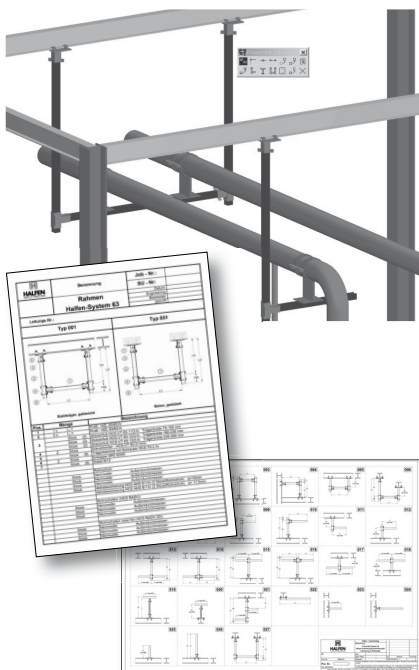

Power - CAD

- Powerclick System 63 - Bibliotheken für PDS, SmartPlant 3D, PDMS, (E3D in Vorbereitung) und SUCad+
 - Rahmen, Stützen und Kragarme sind als Komplettkonstruktionen abrufbar
- Power - CAD**

- Powerclick System 63 – libraries for PDS, SmartPlant 3D, PDMS, (E3D in preparation) and SUCad+
- Frames, supports and cantilever arms are available as complete structural elements

- Typical – Zeichnungsableitung inklusive Stücklisten-erstellung
- Typical – editing of drawings including part-lists

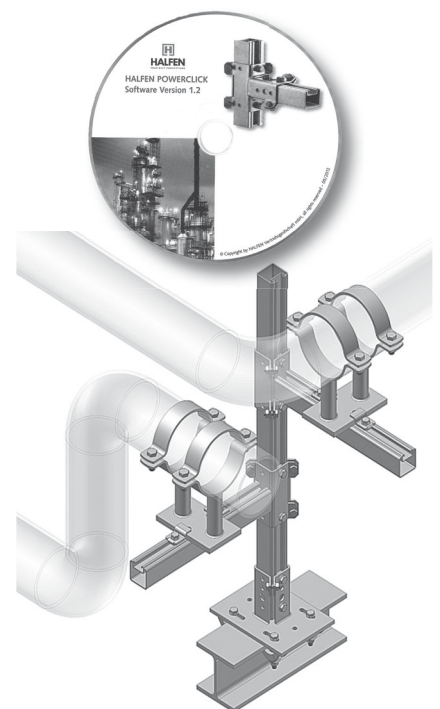





Leviat®

Innovative engineered products
and construction solutions that
allow the industry to build safer,
stronger and faster.



Contact Leviat worldwide

Australia

Unit A, 1 Heinrich Close,
Eastern Creek, Sydney, NSW 2766
Tel: +61 - 2 8808 3100
Email: info.au@leviat.com

Austria

Leonard-Bernstein-Str. 10
Saturn Tower, 1220 Wien
Tel: +43 - 1 - 259 6770
Email: info.at@leviat.com

Belgium

Industrielaan 2
1740 Ternat
Tel: +32 - 2 - 582 29 45
Email: info.be@leviat.com

China

Room 601 Tower D,
Vantone Centre
No. A6 Chao Yang Men Wai Street
Chaoyang District
Beijing P.R. China 100020
Tel: +86 - 10 5907 3200
Email: info.cn@leviat.com

Czech Republic

Pekařská 695/10a
155 00 Praha 5
Tel: +420 - 311 - 690 060
Email: info.cz@leviat.com

Finland

Vädursgatan 5
412 50 Göteborg / Sweden
Tel: +358 (0)10 6338781
Email: info.fi@leviat.com

France

6, Rue de Cabanis
31240 L'Union
Tel: +33 (0)5 34 25 54 82
Email: info.fr@leviat.com

Germany

Liebigstrasse 14
40764 Langenfeld
Tel: +49 - 2173 - 970 - 0
Email: info.de@leviat.com

India

Unit S4, 902, A Wing,
Lodha iThink Techno Campus Building,
Panchpakhadi, Pokharan Road 2,
Thane, 400606
Tel: +91-022 695 33700
Email: info.in@leviat.com

Italy

Via F.lli Bronzetti 28
24124 Bergamo
Tel: +39 - 035 - 0760711
Email: info.it@leviat.com

Malaysia

28 Jalan Anggerik Mokara 31/59
Kota Kemuning,
40460 Shah Alam Selangor
Tel: +603 - 5122 4182
Email: info.my@leviat.com

Netherlands

Oostermaat 3
7623 CS Borne
Tel: +31 - 74 - 267 14 49
Email: info.nl@leviat.com

New Zealand

246D James Fletcher Drive, Otahuhu,
Auckland 2024
Tel: +64 - 9 276 2236
Email: info.nz@leviat.com

Philippines

27F Office A, Podium West Tower,
12 ADB Avenue, Ortigas Center
Mandaluyong City, 1550
Tel: +63 - 2 7957 6381
Email: info.ph@leviat.com

Poland

Ul. Obornicka 287
60-691 Poznań
Tel: +48 - 61 - 622 14 14
Email: info.pl@leviat.com

Singapore

10 Benoi Sector,
Singapore 629845
Tel: +65 - 6266 6802
Email: info.sg@leviat.com

Spain

Polígono Industrial Santa Ana
c/ Ignacio Zuloaga, 20
28522 Rivas-Vaciamadrid
Tel: +34 - 91 632 18 40
Email: info.es@leviat.com

Sweden

Vädursgatan 5
412 50 Göteborg
Tel: +46 - 31 - 98 58 00
Email: info.se@leviat.com

Switzerland

Grenzstrasse 24
3250 Lyss
Tel: +41 (0)800 22 66 00
Email: info.ch@leviat.com

United Arab Emirates

RA08 TB02, PO Box 17225
JAFZA, Jebel Ali, Dubai
Tel: +971 (0)4 883 4346
Email: info.ae@leviat.com

United Kingdom

President Way,
President Park,
Sheffield S4 7UR
Tel: +44 - 114 275 5224
Email: info.uk@leviat.com

USA / Canada

6467 S Falkenburg Road
Riverview, FL 33578
Tel: (800) 423-9140
Email: info.us@leviat.us

For countries not listed

Email: info@leviat.com

Notes regarding this document

© Protected by copyright. The information in this publication is based on state-of-the-art technology at the time of publication. In every case, project working details should be entrusted to appropriately qualified and experienced persons. Leviat shall not accept liability for the accuracy of the information in this document or for any printing errors. We reserve the right to make technical and design changes at any time. With a policy of continuous product development, Leviat reserves the right to modify product design and specification at any time.

Leviat®

Imagine. Model. Make.

Leviat.com