

Leviat®



HALFEN

HALFEN POWERCLICK **REFERENZEN / REFERENCES**



Leviat

We imagine, model and make engineered products and innovative construction solutions that help turn architectural visions into reality and enable our construction partners to build better, safer, stronger and faster.

Leviat is a world leader in connecting, fixing, lifting and anchoring technology.

From the build of new schools, hospitals, homes and infrastructure, to the repair and maintenance of heritage structures, our engineering skills are making a difference around the world.

We provide technical design assistance at every stage of a project, from initial planning to installation and beyond.

Our technical support services range from simple product selection through to the development of a fully customised project-specific design solution.

Every promise we make locally, has the commitment and dedication of our global team behind it. We employ almost 3,000 people at 60 locations across North America, Europe and Asia-Pacific, providing an agile and responsive service worldwide.





>3,000
People

60+
Locations

~20
Countries

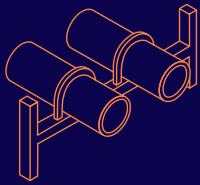

Industrial Technology

Mounting channels, pipe clamps and other versatile framing systems that provide safe fixing in a wide range of industrial applications.

- Modular Framing Systems
- Modular Support Systems
- Mounting Channel Systems
- Accessories for channels, framing & support systems
- General accessories
- Versatile Interior Systems

Other areas of expertise:

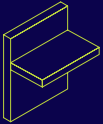

Structural Connections

Systems to form robust, efficient connections, and continuity of concrete reinforcement as necessary, between walls, slabs, columns, beams and balconies, providing structural integrity as well as enhanced thermal and acoustic performance.

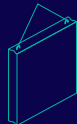

Lifting & Bracing

Systems for the safe and efficient transportation, lifting and temporary bracing of cast concrete elements and tilt-up panels before permanent structural connections are made.

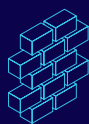

Façade Support & Restraint

Systems for the safe and thermally-efficient fixing of the external building envelope, including brick and natural stone, insulated sandwich panels, curtain walling and suspended concrete façades, and also the repair and strengthening of existing masonry installations.

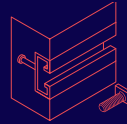

Anchoring & Fixing

Systems for fixing secondary fixtures to concrete, including anchor channels, bolts and inserts; also tension rod systems for roofs and canopies.



Formwork & Site Accessories

Non-structural accessories that complement our engineered solutions and help keep your construction environment operating safely and efficiently, including moulds for casting standard and special concrete elements and construction essentials such as reinforcing bar spacers.

Leviat product ranges:

Ancon | Aschwanden | Connolly | Halfen | Helifix | Isedio | Meadow Burke | Modersohn | Moment | Plaka | Scaldex | Thermomass

HALFEN POWERCLICK SYSTEMÜBERSICHT / SYSTEM OVERVIEW

Modulare Rohrhalterungs-Systeme Modular pipe supports systems

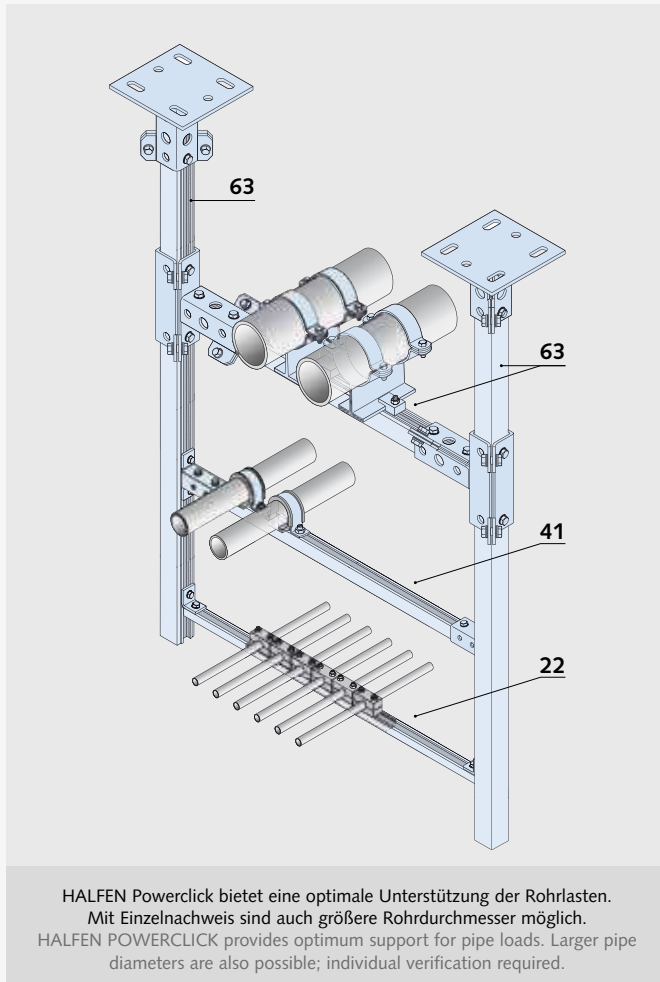

Vorteile Benefits

- › Leichtes Gewicht mit hoher Torsionssteifigkeit
Light weight with high torsional stiffness
- › Modular & justierbar
Modular & adjustable
- › Kein Schweißen
No welding
- › Spart Zeit & Kosten
Time & cost saving

DREI GRÖSSEN – EIN SYSTEM THREE SIZES – ONE SYSTEM



63

41

22



**kompatible Verbindungsteile und
umfangreiches Zubehör**
compatible connecting parts
and extensive accessories



**eine vormontierte POWERCLICK Schraube
für alle Anwendungen**
one type of pre-assembled
POWERCLICK bolt for all applications



HALFEN POWERCLICK

HALFEN POWERCLICK SYSTEMÜBERSICHT / SYSTEM OVERVIEW

Modulare Rohrhalterungs-Systeme Modular pipe supports systems

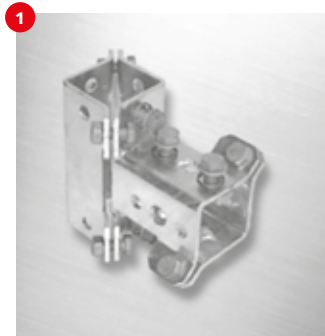

1
Eckverbinder für räumliche Konstruktionen
Corner connector for three-dimensional supports



2
Montageschienen für alle Rohrunterstützungen
Framing channels for all pipe support systems



3
Stützenfuß für alle Anbindevarianten
Support foot for all connection types



4
Trägerklemme für alle Trägergrößen
Beam clamp for all beam sizes

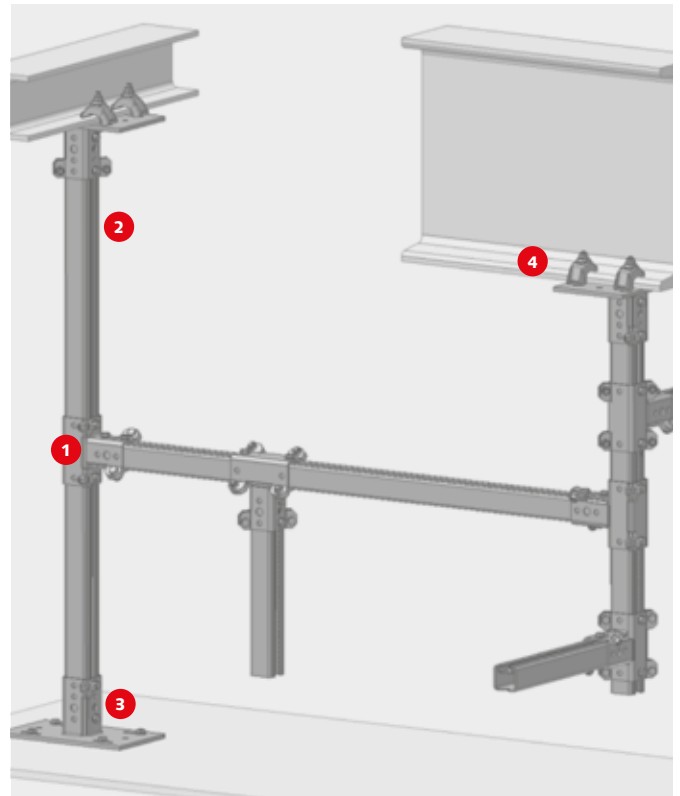

Nur 4 Basisbauteile für räumliche Konstruktionen –
12 Bauteile für 90 % aller Unterstützungsvarianten
Only 4 different basic elements needed to create a main support structure –
12 construction elements for 90% of all supports

HALFEN POWERCLICK 3D Planungstools / 3D planning tools

- › 2D & 3D Bauteil-Bibliotheken (AutoCad, DWG, STEP)
2D & 3D Part Libraries (AutoCad, DWG, STEP)
- › Typen-Kataloge (Excel, PDF)
Typical-Catalogues (Excel, PDF)
- › Aveva Planungs-Tool für PDMS & E3D
Aveva Planning-Tool for PDMS & E3D
- › Intergraph Planungs-Tool für PDS & Smart 3D
Intergraph Planning-Tool for PDS & Smart 3D



HALFEN POWERCLICK CHEMIE / CHEMICAL INDUSTRY

Referenzen

References

- > Allessa, Frankfurt (D)
- > BASF Antwerpen (B)
- > BASF Düsseldorf (B)
- > BASF Freeport (USA)
- > BASF Geismar (USA)
- > BASF Ludwigshafen (D)
- > BASF Minden (D)
- > BASF Münster (D)
- > BASF Schwarzheide (D)
- > BASF Tarragona (E)
- > Bayer AG, Bitterfeld (D)
- > Bayer AG, Wuppertal (D)
- > Bayer Healthcare, Leverkusen (D)
- > BP, Rotterdam (NL)
- > Bunge Loders Crooklan, Maasvlakte (NL)
- > Cargill, Sas van Gent (NL)
- > Cargill, Manchester (GB)
- > Covestro, Antwerpen (B)
- > Covestro, Dormagen (D)
- > Covestro, Leverkusen (D)
- > Clariant, Gersthofen (D)
- > Clariant, Knapsack (D)
- > Cyclis, Schwarzheide (D)
- > Dow, Barry (GB)



CHEMIE / CHEMICAL INDUSTRY

Referenzen

References

- > Dow, Schkopau (D)
- > Dow, Tarragona (E)
- > Dow, Terneuzen (NL)
- > Dow, Vlissingen (NL)
- > DSM, Geelen (NL)
- > DSM, Emmen (NL)
- > DSM, Meppen (D)
- > DuPont, Hamm (D)
- > DyStar, Leverkusen (D)
- > DyStar, Frankfurt (D)
- > Enviro, Roßdorf (D)
- > Evonik, Antwerpen (B)
- > Evonik Degussa, Bitterfeld (D)
- > Evonik, Essen (D)
- > Evonik, Krefeld (D)
- > Evonik, Marl (D)
- > Evonik, Medavox (I)
- > Henkel, Heidelberg (D)
- > Hi-Bis, Bitterfeld (D)
- > Ineos Phenol, Gladbeck (D)
- > Ineos, Zwijndrecht (B)
- > Kao, Emmerich (D)
- > Lanxess, Antwerpen (B)
- > LyondellBasell, Frankfurt (D)
- > LyondellBasell, Maasvlakte (NL)
- > LyondellBasell, Wesseling (D)
- > Novasep, Leverkusen (D)
- > Rütgers, Castrop-Rauxel (D)
- > Sasol, Brunsbüttel (D)
- > Sasol, Marl (D)
- > Shin-Etsu, Rotterdam (NL)
- > Solvay Fluor, Bad Wimpfen (D)
- > Wacker, Burghausen (D)



© novasep

CHEMIE / CHEMICAL INDUSTRY



CHEMIE / CHEMICAL INDUSTRY



CHEMIE / CHEMICAL INDUSTRY



© BASF

HALFEN POWERCLICK BIODIESEL / BIODIESEL

Referenzen

References

- > Air Liquide, Carparroso (I)
- > Air Liquide, Malchin (D)
- > Air Liquide, Halle (D)
- > AT Agrartechnik, Trzebinia (PL)



HALFEN POWERCLICK PHARMA / PHARMA

Referenzen

References

- › Bayer Healthcare, Wuppertal (D)
- › Merck, Darmstadt (D)
- › BYK, Wesel (D)
- › Sanofi Aventis, Frankfurt (D)
- › Ciba, Maastricht (NL)



HALFEN POWERCLICK INFRASTRUKTUR / INFRASTRUCTURE

Referenzen

References

- > Turtmann-Tunnel (CH)
- > Umicore, Brugge (B)



HALFEN POWERCLICK ELEKTRIZITÄTSWERKE / POWER STATIONS

Referenzen

References

- › AEW UW, Kaiseraugst (CH)
- › ewz, Sils im Domleschg (CH)



ELEKTRIZITÄTSWERKE / POWER STATIONS



HALFEN POWERCLICK RAFFINERIEEN UND OFFSHORE / REFINERIES AND OFFSHORE

Referenzen Raffinerien References Refineries

- › BP, Rotterdam (NL)
- › BP, Gelsenkirchen (D)
- › BP, Köln (D)
- › BP, Lingen (D)
- › Shell, Köln (D)
- › Shell, Singapur (SGP)
- › Total, Leuna (D)

Referenzen Offshore References Offshore

- › Wintershall, Nordsee (NL)
- › ONEgas, Nordsee (NL)
- › BP Rhum, Nordsee (UK)
- › RWE/DEA Friedrichskoog, Nordsee (D)



HALFEN POWERCLICK FÖRDERTECHNIK / CONVEYER EQUIPMENT

Referenzen

References

- > Siemens, Kamp-Lintfort (D)
- > Aluminal, Staudt (D)





Leviat®

Innovative engineered products
and construction solutions that
allow the industry to build safer,
stronger and faster.

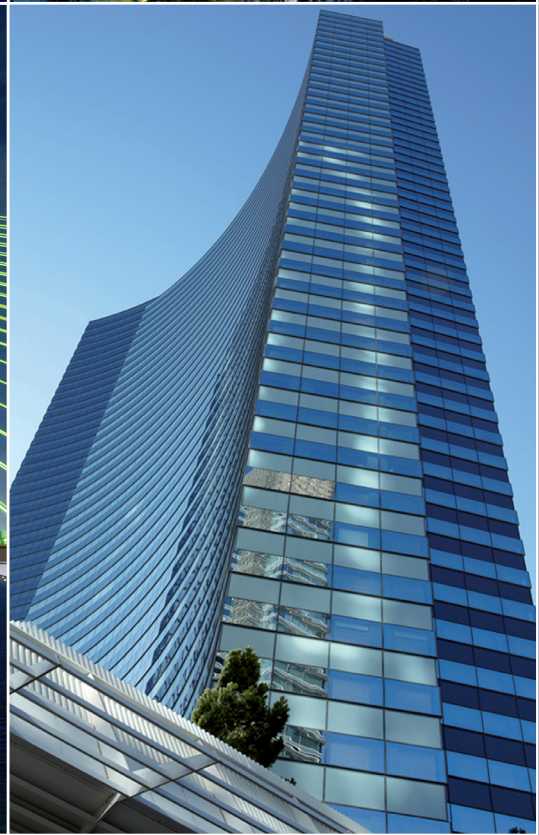

Contact Leviat worldwide

Australia

Unit A, 1 Heinrich Close,
Eastern Creek, Sydney, NSW 2766
Tel: +61 - 2 8808 3100
Email: info.au@leviat.com

Austria

Leonard-Bernstein-Str. 10
Saturn Tower, 1220 Wien
Tel: +43 - 1 - 259 6770
Email: info.at@leviat.com

Belgium

Industrielaan 2
1740 Ternat
Tel: +32 - 2 - 582 29 45
Email: info.be@leviat.com

China

Room 601 Tower D,
Vantone Centre
No. A6 Chao Yang Men Wai Street
Chaoyang District
Beijing P.R. China 100020
Tel: +86 - 10 5907 3200
Email: info.cn@leviat.com

Czech Republic

Pekařská 695/10a
155 00 Praha 5
Tel: +420 - 311 - 690 060
Email: info.cz@leviat.com

Finland

Vädursgatan 5
412 50 Göteborg / Sweden
Tel: +358 (0)10 6338781
Email: info.fi@leviat.com

France

6, Rue de Cabanis
31240 L'Union
Tel: +33 (0)5 34 25 54 82
Email: info.fr@leviat.com

Germany

Liebigstrasse 14
40764 Langenfeld
Tel: +49 - 2173 - 970 - 0
Email: info.de@leviat.com

India

Unit S4, 902, A Wing,
Lodha iThink Techno Campus Building,
Panchpakhadi, Pokharan Road 2,
Thane, 400606
Tel: +91-022 695 33700
Email: info.in@leviat.com

Italy

Via F.lli Bronzetti 28
24124 Bergamo
Tel: +39 - 035 - 0760711
Email: info.it@leviat.com

Malaysia

28 Jalan Anggerik Mokara 31/59
Kota Kemuning,
40460 Shah Alam Selangor
Tel: +603 - 5122 4182
Email: info.my@leviat.com

Netherlands

Oostermaat 3
7623 CS Borne
Tel: +31 - 74 - 267 14 49
Email: info.nl@leviat.com

New Zealand

246D James Fletcher Drive, Otahuhu,
Auckland 2024
Tel: +64 - 9 276 2236
Email: info.nz@leviat.com

Philippines

27F Office A, Podium West Tower,
12 ADB Avenue, Ortigas Center
Mandaluyong City, 1550
Tel: +63 - 2 7957 6381
Email: info.ph@leviat.com

Poland

Ul. Obornicka 287
60-691 Poznań
Tel: +48 - 61 - 622 14 14
Email: info.pl@leviat.com

Singapore

10 Benoi Sector,
Singapore 629845
Tel: +65 - 6266 6802
Email: info.sg@leviat.com

Spain

Polígono Industrial Santa Ana
c/ Ignacio Zuloaga, 20
28522 Rivas-Vaciamadrid
Tel: +34 - 91 632 18 40
Email: info.es@leviat.com

Sweden

Vädursgatan 5
412 50 Göteborg
Tel: +46 - 31 - 98 58 00
Email: info.se@leviat.com

Switzerland

Grenzstrasse 24
3250 Lyss
Tel: +41 (0)800 22 66 00
Email: info.ch@leviat.com

United Arab Emirates

RA08 TB02, PO Box 17225
JAFZA, Jebel Ali, Dubai
Tel: +971 (0)4 883 4346
Email: info.ae@leviat.com

United Kingdom

President Way,
President Park,
Sheffield S4 7UR
Tel: +44 - 114 275 5224
Email: info.uk@leviat.com

USA / Canada

6467 S Falkenburg Road
Riverview, FL 33578
Tel: (800) 423-9140
Email: info.us@leviat.us

For countries not listed

Email: info@leviat.com

Notes regarding this document

© Protected by copyright. The information in this publication is based on state-of-the-art technology at the time of publication. In every case, project working details should be entrusted to appropriately qualified and experienced persons. Leviat shall not accept liability for the accuracy of the information in this document or for any printing errors. We reserve the right to make technical and design changes at any time. With a policy of continuous product development, Leviat reserves the right to modify product design and specification at any time.

Leviat®

Imagine. Model. Make.

Leviat.com