

FLEXIBLE FRAMING CONNECTIONS

Technical Product Information



MT-FFC 17-E

Adjustable Cantilever

- Time saving
- Economical
- Space efficient

Leviat

We imagine, model and make engineered products and innovative construction solutions that help turn architectural visions into reality and enable our construction partners to build better, safer, stronger and faster.

Leviat is a world leader in connecting, fixing, lifting and anchoring technology.

From the build of new schools, hospitals, homes and infrastructure, to the repair and maintenance of heritage structures, our engineering skills are making a difference around the world.

We provide technical design assistance at every stage of a project, from initial planning to installation and beyond.

Our technical support services range from simple product selection through to the development of a fully customised project-specific design solution.

Every promise we make locally, has the commitment and dedication of our global team behind it. We employ almost 3,000 people at 60 locations across North America, Europe and Asia-Pacific, providing an agile and responsive service worldwide.





>3,000
People

60+
Locations

~20
Countries

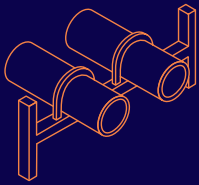

Industrial Technology

Mounting channels, pipe clamps and other versatile framing systems that provide safe fixing in a wide range of industrial applications.

- Modular Framing Systems
- Modular Support Systems
- Mounting Channel Systems
- Accessories for channels, framing & support systems
- General accessories
- Versatile Interior Systems

Other areas of expertise:

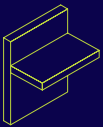

Structural Connections

Systems to form robust, efficient connections, and continuity of concrete reinforcement as necessary, between walls, slabs, columns, beams and balconies, providing structural integrity as well as enhanced thermal and acoustic performance.

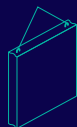

Lifting & Bracing

Systems for the safe and efficient transportation, lifting and temporary bracing of cast concrete elements and tilt-up panels before permanent structural connections are made.

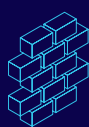

Façade Support & Restraint

Systems for the safe and thermally-efficient fixing of the external building envelope, including brick and natural stone, insulated sandwich panels, curtain walling and suspended concrete façades, and also the repair and strengthening of existing masonry installations.



Anchoring & Fixing

Systems for fixing secondary fixtures to concrete, including anchor channels, bolts and inserts; also tension rod systems for roofs and canopies.



Formwork & Site Accessories

Non-structural accessories that complement our engineered solutions and help keep your construction environment operating safely and efficiently, including moulds for casting standard and special concrete elements and construction essentials such as reinforcing bar spacers.

Leviat product ranges:

Ancon | Aschwanden | Connolly | Halfen | Helifix | Isedio | Meadow Burke | Modersohn | Moment | Plaka | Scaldex | Thermomass

HALFEN FLEXIBLE FRAMING CONSTRUCTIONS

Contents

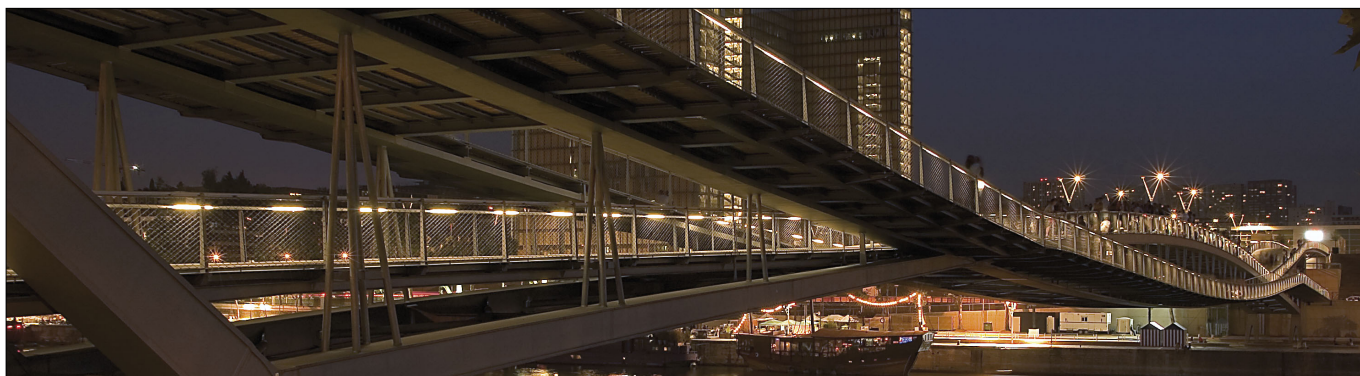

HALFEN Flexible Framework Constructions

- General overview	4
- European standards/Calculation method	5
- Application examples	6
- Designing with HALFEN – How to start your project	7
- System 52 – for heavy duty requirements	8-10
Framing Channels, bolts, fittings, channel ring	
- System 41 – for medium duty requirements	11-22
Framing Channels, bolts, fittings, channel ring	
NEW in System 41 – The HALFEN Adjustable Cantilever	16-22
- System 36 – for light duty requirements	23-24
Framing Channels, bolts, fittings	
- System 28 – for light duty requirements	25
Framing Channels, bolts, fittings, channel ring	
- Framework constructions with system 28/36	26

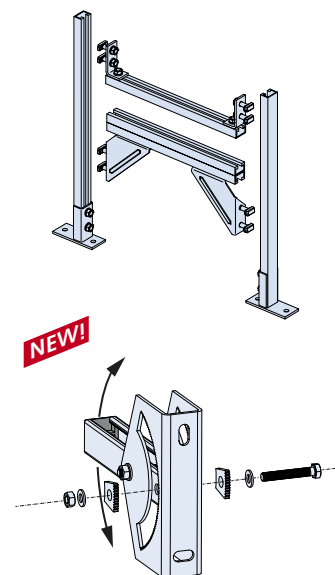

HALFEN Cantilevers

- Overview Cantilever brackets	27
- Cantilever brackets – Type 52	28-29
- Cantilever brackets – Type 41	30-31
- Accessory Bracket KON-Z for 41/36/28 cantilevers	31
- Cantilever brackets – Type 36	32-33
- Cantilever brackets – Type 28	33

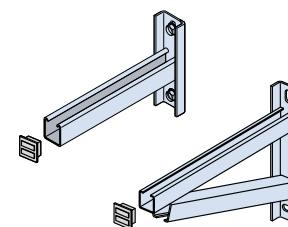

Additional information for all HALFEN Framing channels and HALFEN Bolts, for example, on bearing loads and notes on dimensioning and material, is content of Technical Product Information **MT-FBC-E "HALFEN Flexible bolt connections, "**.

Available for download as a pdf file at

www.halfen.com – Brochures – Catalogues – Framing Systems.



HALFEN FLEXIBLE FRAMING CONSTRUCTIONS

Contents



HALFEN Framing System Accessories

- Beam clamp/Clamp plate	34-35
- Nuts, washers	36
- Threaded Rod, Hexagon Bolts, Coupler Sleeves, Ring nuts	37
- Vibration absorber (with example airstream channel)	38
- Channel end caps, channel cover strips	39

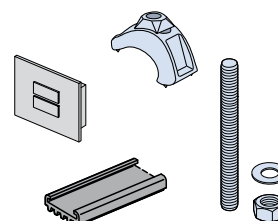

Pipe clamps, pipe supports

- Type selection	40
- Pipe clamp Alpha	41
- Pipe clamp assembly set	42
- Pipe clamp Beta	43
- Pipe clamp Gamma	44
- Pipe clamp Delta	45
- Pipe supports	46
- Accessories	47-49

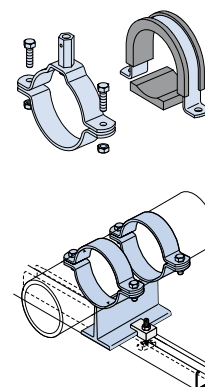

Appendix

- Pipe weights and support spacing	50
- Pipe dimension	51-52
- Pipe fixings under bridges	53
- Specification texts	54-55
- Addresses/contacts	57

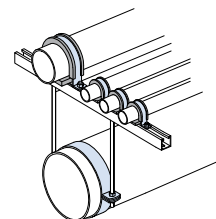

HALFEN FLEXIBLE FRAMING CONSTRUCTIONS

General Overview

Flexible framework constructions offer a whole range of benefits:

- quick assembly of supporting frames
- on-site adjustable, due to flexible assembly system in channel slots
- existing framework constructions are easily altered or up-graded
- corrosion protection of all equipment is not compromised by bolting
- no meticulous preliminary planning of drilling templates necessary
- construction tolerances can be compensated on-site
- large selection of material from low to high loads

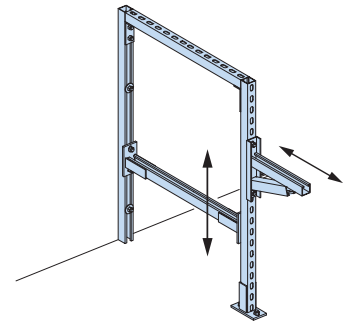

With HALFEN Framing channels you avoid:

- time consuming planning of inflexible bolted fixings
- costly corrosion protection work on completed or existing structural components
- costly manufacturing of bolting
- preliminary or subsequent mechanical work on-site i.e. drilling and welding

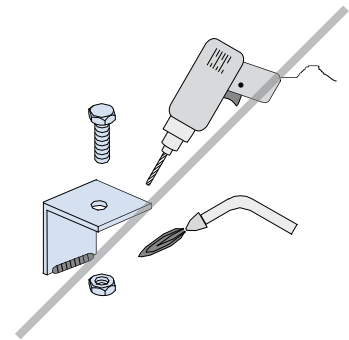

Quality

Quality is an outstanding characteristic of our products. All our materials and products are subject to stringent quality controls.

A quality audit by the DNV GL confirmed that our quality management system fulfils the requirements of ISO 9001:2015.



Additional product information

You can find more information, for example, on bearing loads and notes on dimensioning and material, for all HALFEN Framing channels in our catalogue **MT-FBC-E "HALFEN Flexible bolt connections, Technical Product Information"**.

Available for download as a pdf file at www.halfen.com – **Brochures – Catalogues – Framing Systems.**

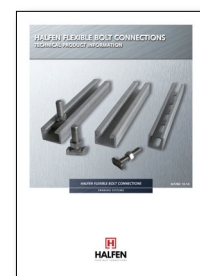

HALFEN FLEXIBLE FRAMING CONSTRUCTIONS

General Overview

European standards EN 1090 / EN 1993

The new EN 1090 series of standards replace the previous DIN 18800-7 Standard, regulating execution of steel structures and manufacturing qualifications.

European standard EN 1090-1 specifies requirements for conformity assessment (CE marking) of structural components which will be placed on the European market as construction products. The conformity assessment covers production characteristics and where appropriate, the structural design characteristics.

The EN 1090-2 Standard regulates the requirements applicable to the execution of steel structures. This standard applies to structures that are verified according to the appropriate section of EN 1993 (EC3).

The phase-out period for DIN 18800-7 ended on the 30th of June 2014. Basis for the evaluation of conformity of steel construction products is the system of assessment of conformity 2+ according to Construction Products Regulation (CPR) EU No. 305/2011.



EN 1090-1, EN 1090-2
2499 – CPR-0113070-00-01



The CE marking confirms conformity with the declared performance of HALFEN products and with all relevant European harmonized standards in the European Union.

HALFEN Framing channels are also subject to these regulations. To meet CE evaluation obligations the marked products are statically verified in accordance with EN 1993 and the principal performance characteristics are detailed in the respective Declaration of Performance, CONF-DOP_KON. CE marking is mandatory from the 1st of July 2014 when distributing load bearing metallic construction products in the European market.

We are certified by the notified Body ZDH-ZERT GmbH. Apart from production, the certification includes the method of calculation required by our Engineers and their respective qualifications.

Design method

The European standard EN 1993 was created with the intention to establish uniform calculation methods for steel structures across Europe.

However, because these calculation methods have not yet been adopted in all industries we have decided to include two sets of values for cantilever load capacities in the following tables.

- working loads will continue to be defined as "allow. F" and
- design values of the resistance will be defined as „F_{Rd}“.

The term "design value" is taken from the current applicable standards, for example EN 1993 (EC3), with new safety concept, and must be strictly differentiated from the term "allowable load". The European standard which is based on the so called "partial safety factors" is applied to material resistance as well as to the action (load).

The following verification is required:

$$F_{Ed} \leq F_{Rd}$$

F_{Ed} = calculation value for action
F_{Rd} = design value for resistance

The traditional, deterministic safety concept however, is based on the method of using a global safety factor for material resistance and is known as the "allowable load method" or "allowable tension method". These methods are used in mechanical and apparatus engineering. In these cases the allowable values for load capacity are calculated. Verification is as follows:

$$F \leq \text{allow. F}$$

F = load on the structure
allow. F = allowable load

HALFEN FLEXIBLE FRAMING CONSTRUCTIONS

Application Examples

Flexible framework construction

Standardised complete system consists of:



HALFEN Framing channels



HALFEN Bolts / Locking plates



HALFEN Connection elements

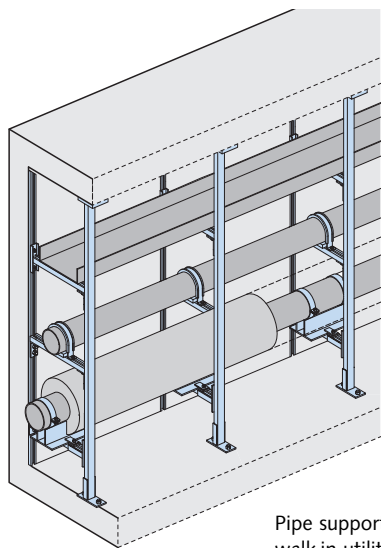

Pipe support in walk-in utility tunnels.

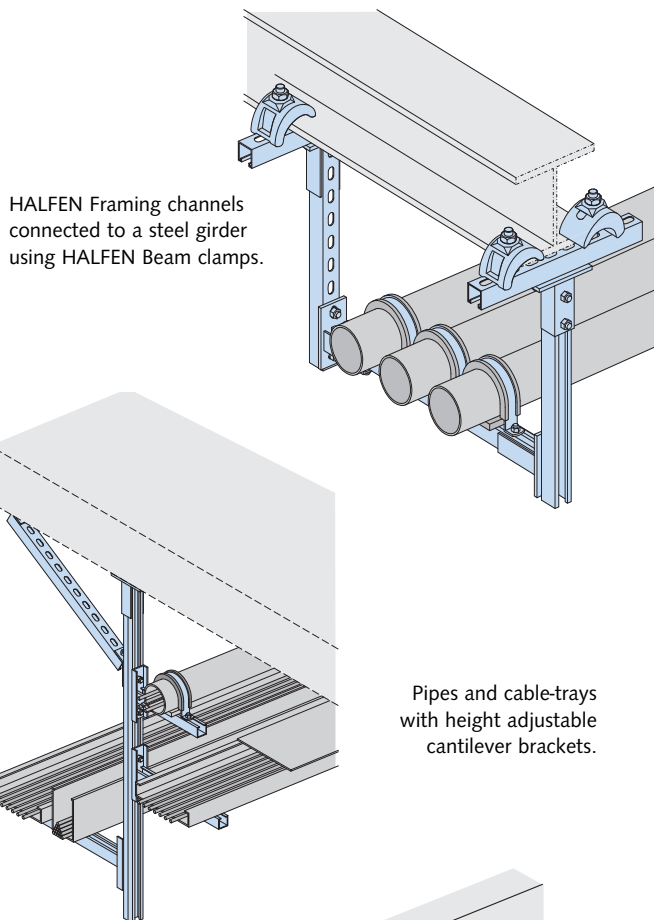
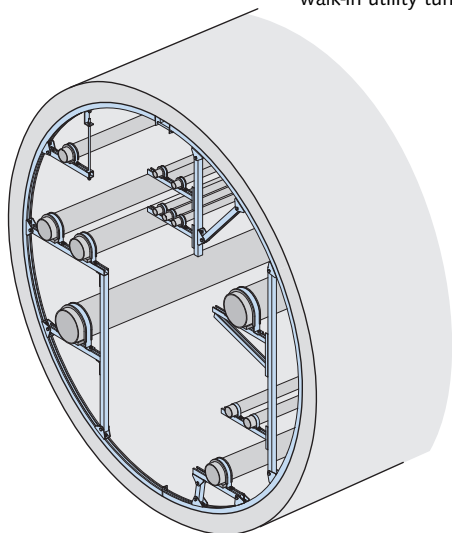

HALFEN Framing channels connected to a steel girder using HALFEN Beam clamps.

Pipes and cable-trays with height adjustable cantilever brackets.

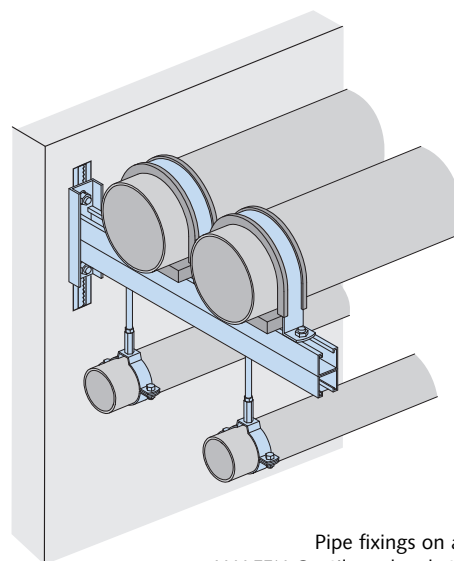

Pipe fixings on a HALFEN Cantilever bracket.

HALFEN Channels can be fixed to numerous types of support structures:

- clamped on sectional steel supports
- welded onto structural steel members
- bolted onto HALFEN Cast-in channels
- fixed onto concrete or brickwork using dowels, etc.

HALFEN Bolts and locking plates can be inserted anywhere on the framing channels in the profile slot allowing a quick, safe and fully adjustable connection of components.

HALFEN FLEXIBLE FRAMING CONSTRUCTIONS

We offer complete design services

Designing with our support team

Our technical department starts with your configuration sketch, including information on the culvert radius R [mm].

From your sketch...

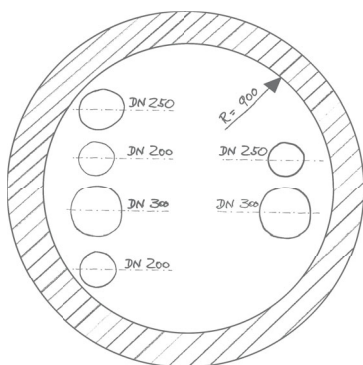

..to the detailed design and realisation

Our pipe support systems are designed and manufactured from a mix of standard and custom elements to suit the specific of your project.

The Engineering Support Team always endeavour to find the best balance between safety and economy. This is done in conjunction with the customer, with whom there is an open dialogue throughout the design process.

For more information please contact us.

Please see the back page of this catalogue for regional contact addresses or www.halfen.com

Serrated framing channel

Alternatively serrated anchor channel

Example for hinged beam



Construction example for a medium duty framing channel ring HCS-SRI
Available in hot-dip galvanized
[Available in stainless steel](#)

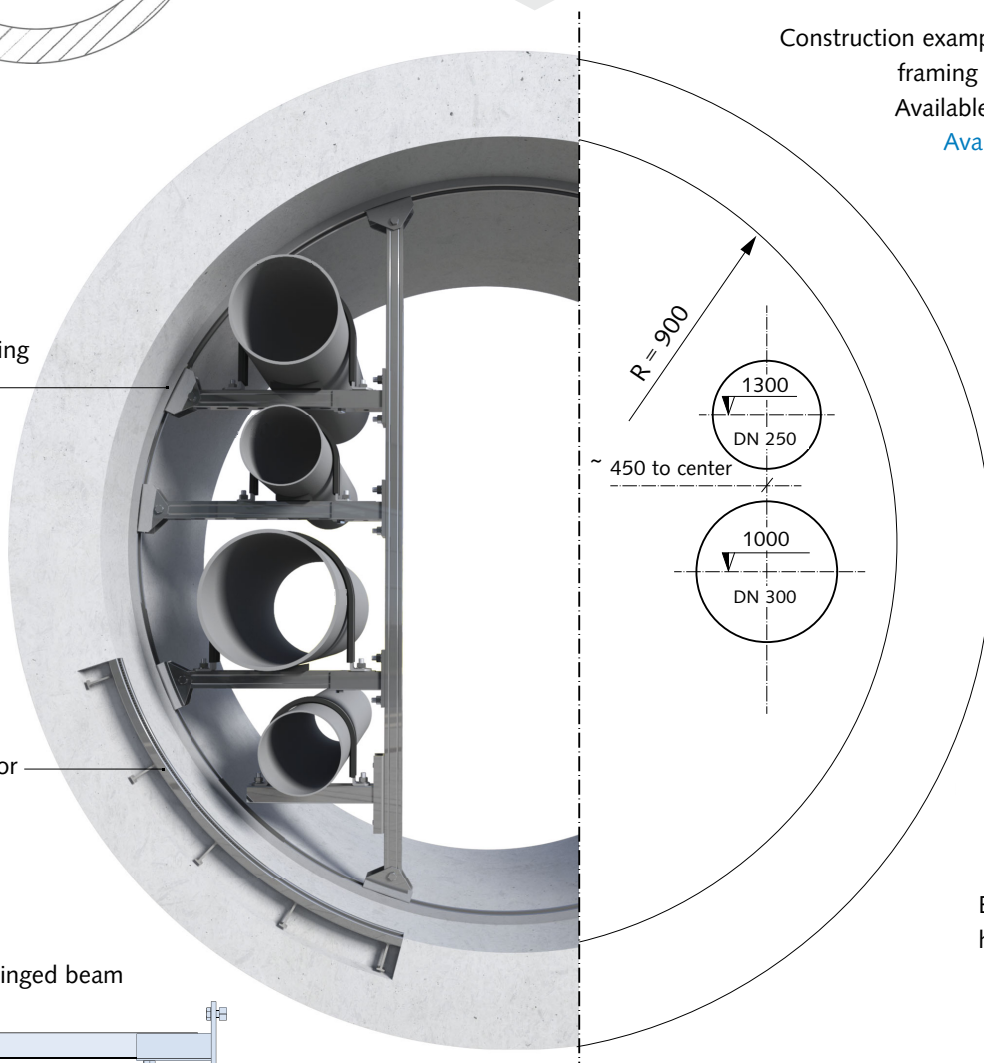

Example for hinged support

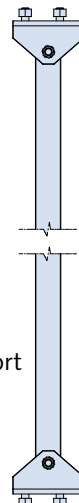

HALFEN FLEXIBLE FRAMING CONSTRUCTIONS

System 52 - Heavy Duty

System 52

The framing system for **heavy loads** consists of the hot-rolled channel HM 52/34 and 10 connection elements. For greater bending requirements the double channel HM 52/34 D is available. System 52 is also available as a channel ring system, which is made to the customer specifications (see page 10).

 **Framing channel HM 52/34**
hot-rolled

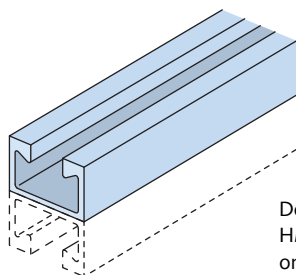
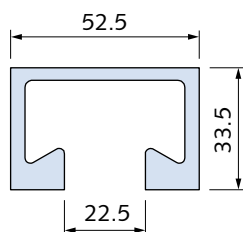

Double channel
HM 52/34 D
on request

HM 52/34		
Material	Order no. 0280.	Length [mm]
WB	190-00002	6070
FV	190-00003	
A4	190-00001	

Channel data, measurements, load bearing capacities, etc. can be found in the Technical Product Information **MT-FBC-E "HALFEN Flexible bolt connections"** (see page 17).

Accessories

HPE 52/34 Channel end caps
PA-22 Channel cover

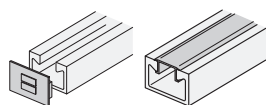

see page 39

VUS 52/34 Washers

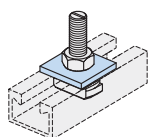

see page 36

SDM 41/8 Vibration absorber

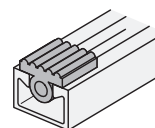

see page 38



HALFEN Bolt **HS 50/30**,
HALFEN Bolt with nib **HSR 50/30**
Locking plate **GWP 50/30**

Bolt data, measurements, load bearing capacities, etc. can be found in the Technical Product Information **"HALFEN Flexible bolt connections" MT-FBC (see page 21)**.



Connection fittings HVT 52

Standard dimensions [mm]:
Unless otherwise stated, the following dimensions apply to all connection elements for HVT 52.

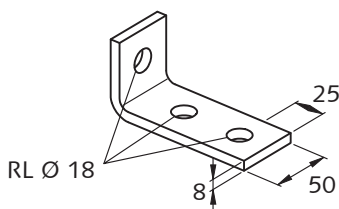

Recommended HALFEN Bolts:
HS 50/30 - M16 × 40 and
HSR 50/30 - M16 × 40

Connecting elements - System 52

FV = hot dip galvanized		A4 = stainless steel W1.4571/1.4401	
Article name	Order no. 0312.040-	Article name	Order no. 0312.040-
HVT - 52 - 1 - FV	00001	HVT - 52 - 1 - A4	00011
HVT - 52 - 2 - FV	00002	HVT - 52 - 2 - A4	00012
HVT - 52 - 3 - FV	00003	HVT - 52 - 3 - A4	00013
HVT - 52 - 4 - FV	00004	HVT - 52 - 4 - A4	00014
HVT - 52 - 5 - FV	00005	HVT - 52 - 5 - A4	00015
HVT - 52 - 6 - FV	00006	HVT - 52 - 6 - A4	00016
HVT - 52 - 7 - FV	00007	HVT - 52 - 7 - A4	00017
HVT - 52 - 8 - FV	00008	HVT - 52 - 8 - A4	00018
HVT - 52 - 9 - FV	00009	HVT - 52 - 9 - A4	00019
HVT - 52 - 10 - FV	00010	HVT - 52 - 10 - A4	00020

HALFEN FLEXIBLE FRAMING CONSTRUCTIONS

System 52 - Heavy Duty

Application examples

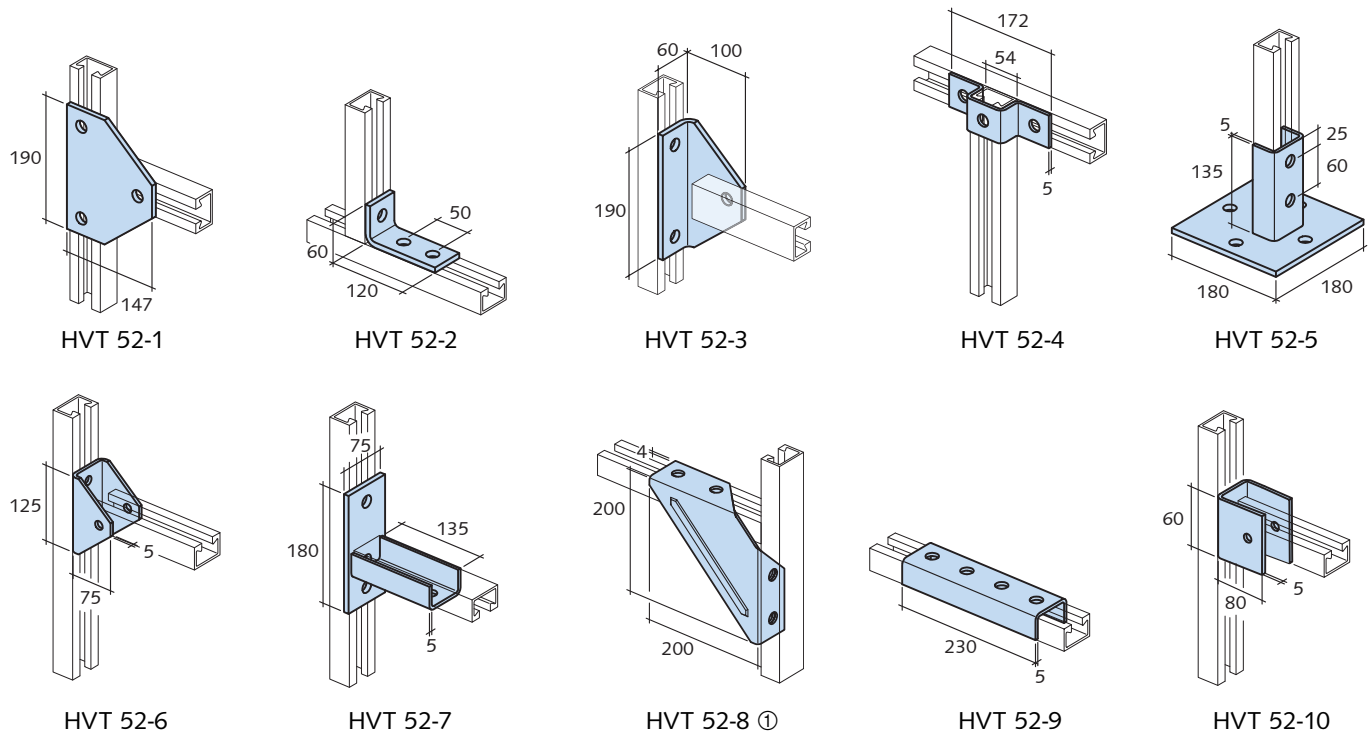

① **Assembly note for fitting system HVT 52-8**

Because of their unique shape two HVT 52-8 elements can be installed directly adjacent to each other when used for channel-cross connections on the same level.

Note: Each detail shows only one of many possible applications.

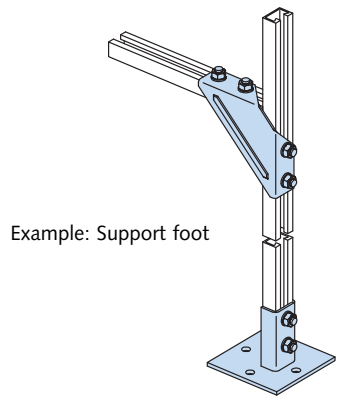
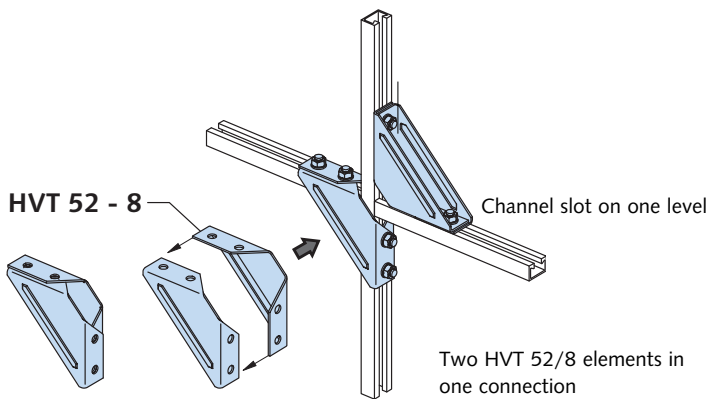

HALFEN FLEXIBLE FRAMING CONSTRUCTIONS

System 52 – Heavy Duty – Construction Examples

Framework constructions

Pre-assembled components

HALFEN System 52 is used for heavy component assembly, e.g. in cable ducts or utility tunnels.

Base profiles are the framing channels HM 52/34 and for larger bending requirements HM 52/34 D.

The framing channels and connection fittings are available hot-dip galvanized, or in A4 stainless steel.

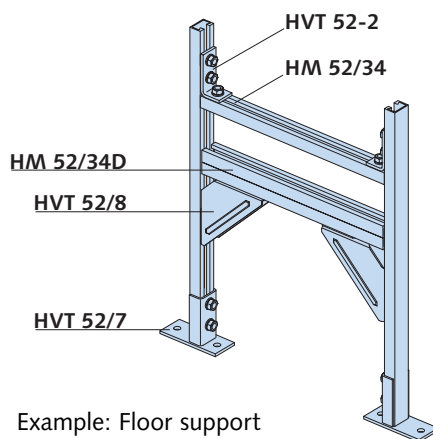
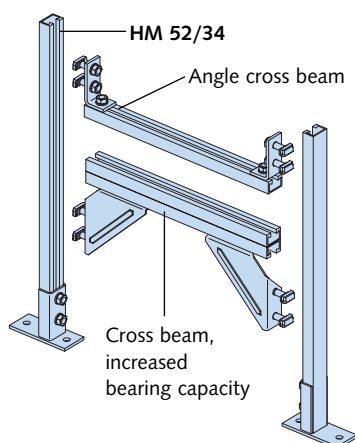

Example: Floor support

Frames are designed by our engineering team, in accordance with the customer's requirements, and are made to order from stock material.

Channel ring

Example: Channel ring for utility tunnels (eg. in culverts)

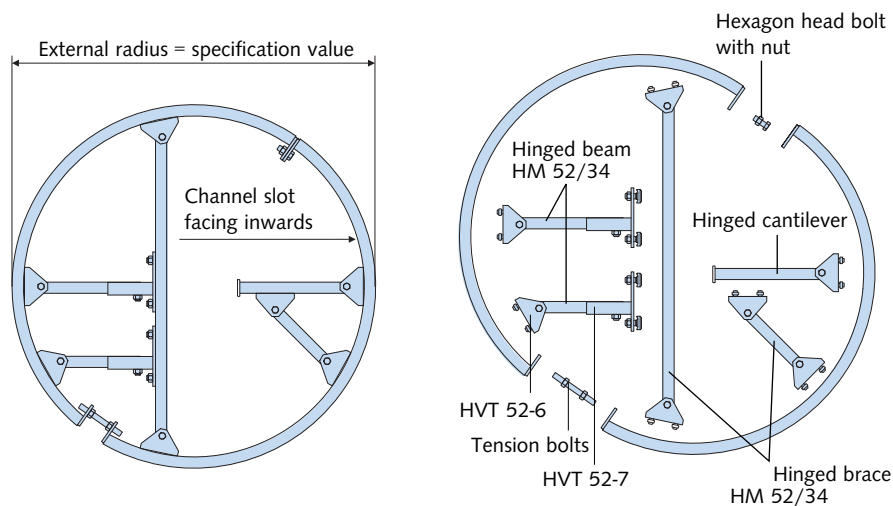

Channel ring systems are designed by our engineering team in conjunction with the customer. Rings are made to order, primarily from material available from stock.

Recommended HALFEN Bolts for assembling fitting system HVT-52:

HS 50/30 M16 x 40 FV 4.6
0350.090-00041

HSR 50/30 M16 x 40 FV 8.8
0351.090-00001

(hot-dip galvanized finish)

HS 50/30 M16 x 40 A4-50
0350.090-00006

(stainless steel finish)

Delivery times on request.
Dowel fixing set if required;
please order item separately.

If you have any further questions:

Our technical department and our field support technicians will gladly advise and support you with solutions when using HALFEN Framing systems.

For more information contact HALFEN

Please see the back page of this catalogue for regional contact addresses or at www.halfen.com

HALFEN FLEXIBLE FRAMING CONSTRUCTIONS

HALFEN System 41 – Medium Duty

System 41

The framing system for **medium loads** can be used in combination with all HALFEN 41 series framing channels. System 41 is also available as a channel ring system, which can be made to customer specifications (see page 15).



HM and HL 41/41
cold-rolled

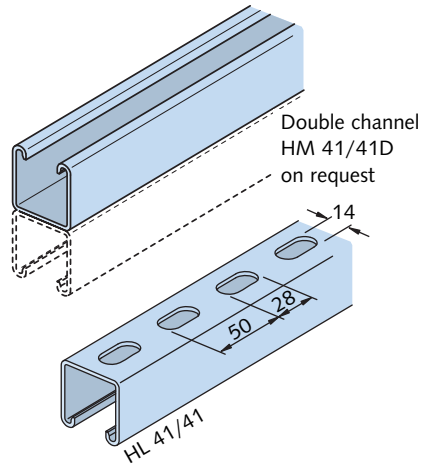
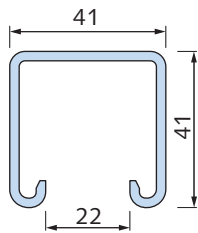

Double channel
HM 41/41D
on request



HZM and HZL 41/41
cold-rolled, serrated

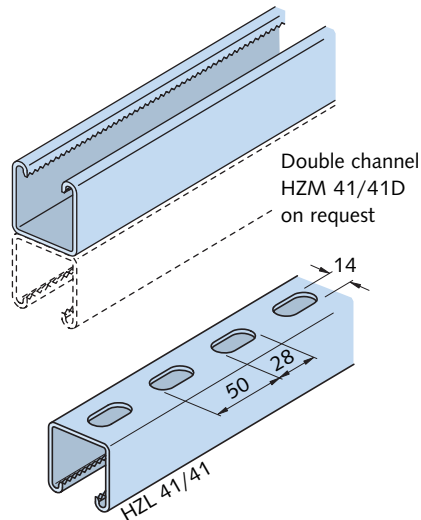
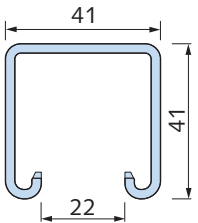

Double channel
HZM 41/41D
on request



HM and HL 41/22
cold-rolled

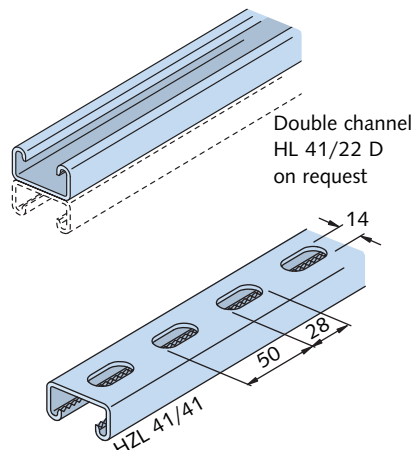
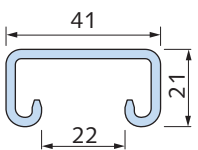

Double channel
HL 41/22 D
on request

HM 41/41 and HL 41/41		
Material	Order no.	Length [mm]
HM 41/41 0280.		
WB	080-00001	6000
SV	080-00002	
FV	080-00003	
A4	080-00004	
HL 41/41 0281.		
WB	010-00001	6000
SV	010-00003	
FV	010-00002	
A4	010-00004	
HM 41/41 D 0280.		
WB	150-00001	6000
FV	150-00003	
A4	150-00002	

HZM 41/41 and HZL 41/41		
Material	Order no.	Length [mm]
HZM 41/41 0284.		
WB	010-00001	6000
FV	010-00002	
A4	010-00003	
HZL 41/41 0283.		
WB	010-00001	6000
FV	010-00002	
A4	010-00003	
HZM 41/41 D 0284.		
WB	030-00001	6000
FV	030-00002	
A4	030-00003	

HM 41/22 and HL 41/22		
Material	Order no.	Length [mm]
HM 41/22 0280.		
WB	120-00001	6000
SV	120-00002	
FV	120-00003	
A4	120-00004	
HL 41/22 0281.		
WB	020-00001	6000
SV	020-00003	
FV	020-00002	
A4	020-00004	
HM 41/22 D 0280.		
WB	160-00001	6000
FV	160-00002	
A4	160-00003	

HALFEN FLEXIBLE FRAMING CONSTRUCTIONS

System 41 - Medium Duty

System 41



HZM and HZL 41/22

cold-rolled, serrated

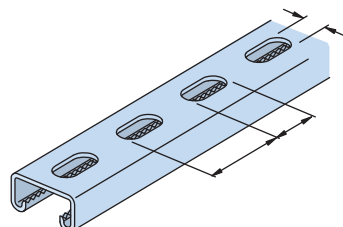
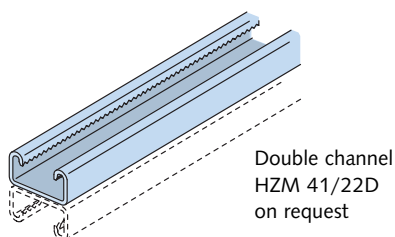
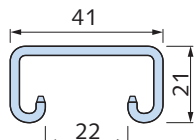

HZM 41/22 and HZL 41/22		
Material	Order no.	Length [mm]
HZM 41/22 0284.		
WB	020-00001	6070
FV	020-00002	
A4	020-00003	
HZL 41/22 0283.		
WB	020-00001	6000
FV	020-00002	
A4	020-00003	
HZM 41/22 D 0284.		
WB	040-00001	6070
FV	040-00002	
A4	040-00003	

Channel data, measurements, load bearing capacities, etc. can be found in the Technical Product Information MT-FBC-E "HALFEN Flexible bolt connections" (see pages 33-34 and 38-40).

Accessories

HPE 41/41 Channel end caps

PA - 41 Channel cover

SDM 41/8 Vibration absorber

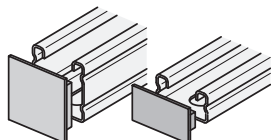

see page 39

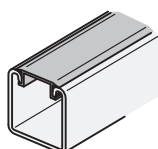

see page 39

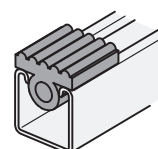

see page 38



HALFEN Bolt HS 41/41

HALFEN Bolt serrated/toothed HZS 41/41

HALFEN Bolt serrated/toothed HZS 41/22

Locking plate GWP 41/41

Locking plate with short spring GWP 41/41 SN

Locking plate with long spring GWP 41/41 SH

Bolt data, measurements, load bearing capacities, etc. can be found in the Technical Product Information MT-FBC-E "HALFEN Flexible bolt connections" (see page 41-42).



Connection fittings HVT 41

Standard dimensions [mm]:

Unless otherwise stated, all HVT 41 connectors are made with the following typical dimensions.

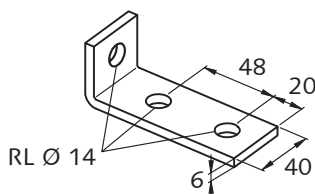

Recommended HALFEN Bolts:

HS 41/41 - M12 × 35 FV and A4-70,

HZS 41/41 - M12 × 30, ZL

(ZL = zink flke coating)

HZS 41/22 - M12 × 35 FV 8.8 or

GWP 41/41 - F M12 FV or A4

with HSK M12 × 35 FV or A4

HALFEN FLEXIBLE FRAMING CONSTRUCTIONS

System 41 - Medium Duty

Application examples

Article name	Order no.	
	FV = hot-dip galvanized	A4 = stainless steel
	0312.	0312.
HVT 41 - 08	030-00001	
HVT 41 - 10	030-00002	030-00049
HVT 41 - 11 ①	030-00003	
HVT 41 - 13	030-00004	030-00051
HVT 41 - 15	030-00005	030-00052
HVT 41 - 19	030-00006	
HVT 41 - 22	030-00008	030-00054
HVT 41 - 23 ①	030-00009	
HVT 41 - 25	030-00010	030-00056
HVT 41 - 26	030-00011	030-00057
HVT 41 - 27	030-00012	030-00058
HVT 41 - 31	030-00013	
HVT 41 - 33	030-00014	
HVT 41 - 37	030-00018	
HVT 41 - 40	030-00019	
HVT 41 - 41L	030-00020	
HVT 41 - 41R	030-00021	
HVT 41 - 43	030-00022	
HVT 41 - 44	030-00023	
HVT 41 - 45	030-00024	
HVT 41 - 46	030-00025	030-00071
HVT 41 - 47	030-00026	030-00072
HVT 41 - 49	030-00027	
HVT 41 - 57	030-00029	030-00074
HVT 41 - 58	030-00030	030-00075
HVT 41 - 65	030-00032	
HVT 41 - 66	030-00033	
HVT 41 - 67	030-00034	
HVT 41 - 68	030-00035	030-00079
HVT 41 - 73	030-00037	
HVT 41 - 75 ①	030-00038	
HVT 41 - 77	030-00039	030-00082
HVT 41 - 78	030-00040	030-00083
HVT 41 - 84	030-00041	030-00084
HVT 41 - 97	030-00047	

① on request

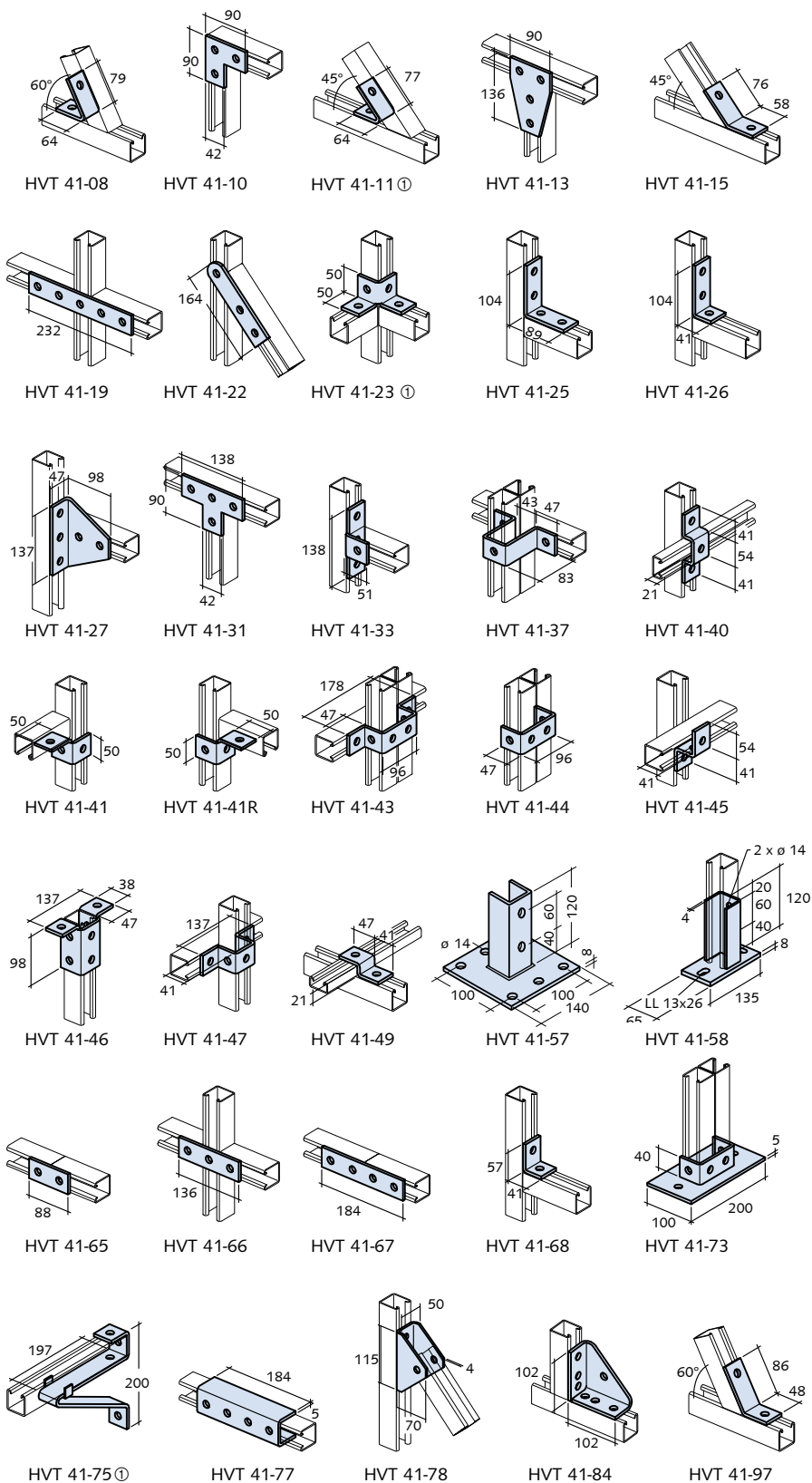

Note: Each drawing shows only one of many possible applications.

HALFEN FLEXIBLE FRAMING CONSTRUCTIONS

Adjustable Framework Construction – Accessories for System 41

U-Clamp-Plate KUS – 41 System

KUS U-clamp-plates fit on all HALFEN 41 System channels

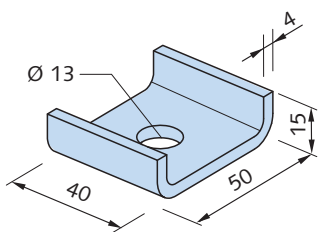

Assembly diagram

e.g. channel 41/62

Threaded rod

locking plate 41/41

KUS

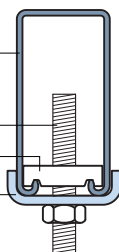

U-clamp-plate KUS	
Type	Order no.
KUS FV hot-dip galvanized	0314.000-00001
KUS A4 stainless steel	0314.000-00002

Beam clamps – 41 System

Beam clamps for 41 series; used in pairs

HVT 41 - 85

for channels 41/41, 41/22 and 41/22D

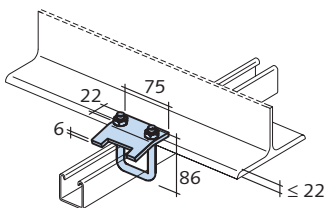

Load cap. per clamp pair: **4.55 kN**

Clamping thickness: max. 22 mm

HVT 41 - 85	
Type	Order no.
HVT 41 - 85 - FV	0312.030-00042
HVT 41 - 85 - A4	0312.030-00085
FV = hot-dip galvanized A4 = stainless steel	

HVT 41 - 86

for channels 41/41D, 41/62 and 41/83

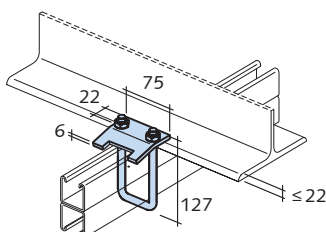

Load cap. per clamp pair: **4.55 kN**

Clamping thickness: max. 22 mm

HVT 41 - 86	
Type	Order no.
HVT 41 - 86 - FV	0312.030-00044
HVT 41 - 86 - A4	0312.030-00086
FV = hot-dip galvanized A4 = stainless steel	

HVT 41 - 89

for all channels in the 41 series

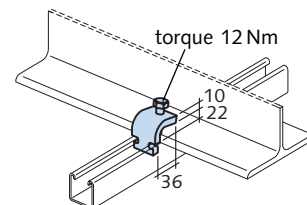

Load cap. per clamp pair: **3.0 kN**

Load cap. per clamp pair for channel HLL 41/41: **2.5 kN**

Clamping thickness: max. 22 mm

HVT 41 - 89	
Type	Order no.
HVT 41 - 89 - FV	0312.030-00046
HVT 41 - 89 - A4	on request
FV = hot-dip galvanized A4 = stainless steel	

HALFEN FLEXIBLE FRAMING CONSTRUCTIONS

System 41 – Medium Duty – Construction Example

Channel ring

Channel ring HCS - 41 - SRI:

Base profiles for channel ring system 41:

HM 41/22 for finish **FV** (hot-dip galvanized) or

HZM 41/22 serrated, for finish in **A4** (stainless steel)

Locking plates for assembly of fitting system HVT - 41:

GWP 41/41, F M12 FV (hot-dip galvanized) 0322.020-00001

GWP 41/41, F M12 GV (electroplated) 0322.020-00002

GWP 41/41, F M12 A4 (stainless steel) 0322.020-00003

Note: Minimum external radius;
channel HM 41/22: $R_a \geq 750$ mm

Channel ring systems are made to customer specifications, supported by our engineering team and made, including assembly material, by our production team.

Our technical department requires detailed drawings, as well as information on the required external radius R_a [mm]. Alternatively the corresponding order numbers are listed in the table below:

Article name and order no.	
Material: FV = hot-dip galvanized	Order no. 0304. ...
HCS - 41 - SRI - P - FV Radius R_a	010-00002 ①
HCS - 41 - SRI - M - FV	020-00002
Material: A4 = stainless steel	
HCS - 41 - SRI - P - A4 Radius R_a	010-00001 ①
HCS - 41 - SRI - M - A4	020-00001
① Always specify external radius R_a [mm] when ordering	

Delivery times on request.

If necessary, dowel fixing sets have to be ordered separately.

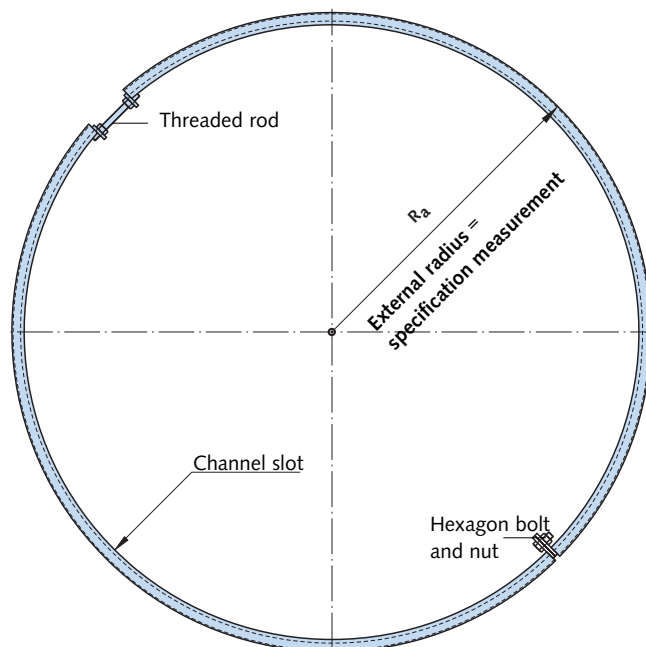

HCS - 41 - SRI - P Channel order includes:
Channel 2 channel ring segments made from channel HM 41/22, curved with external radius R_a [mm] = order length, with welded-on head plates

HCS - 41 - SRI - M Set includes:
Installation set 1 × Threaded rod M12 × 120
1 × Hex. head bolt HSK - M12 × 25
3 × Hexagonal nut M12

Pre-assembled components for channel ring systems

We deliver premounted hinged beams and supports for supply and disposal pipes, manufactured by customer specification. Further Information can be found at page 7.

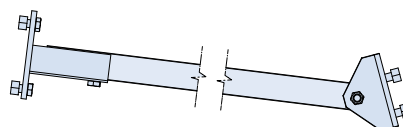
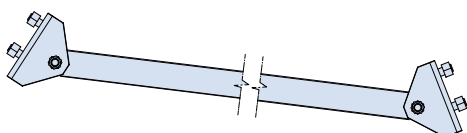

HALFEN Adjustable Cantilever

The advantages at a glance

A Revolution in tunnel pipe support. The HALFEN Adjustable Cantilever combines the established high load bearing of the medium duty system with much faster installation. Specifically designed for tunnels or other areas with a curved or inclined substrate. It is not necessary to know the cantilever angle at the time of design.

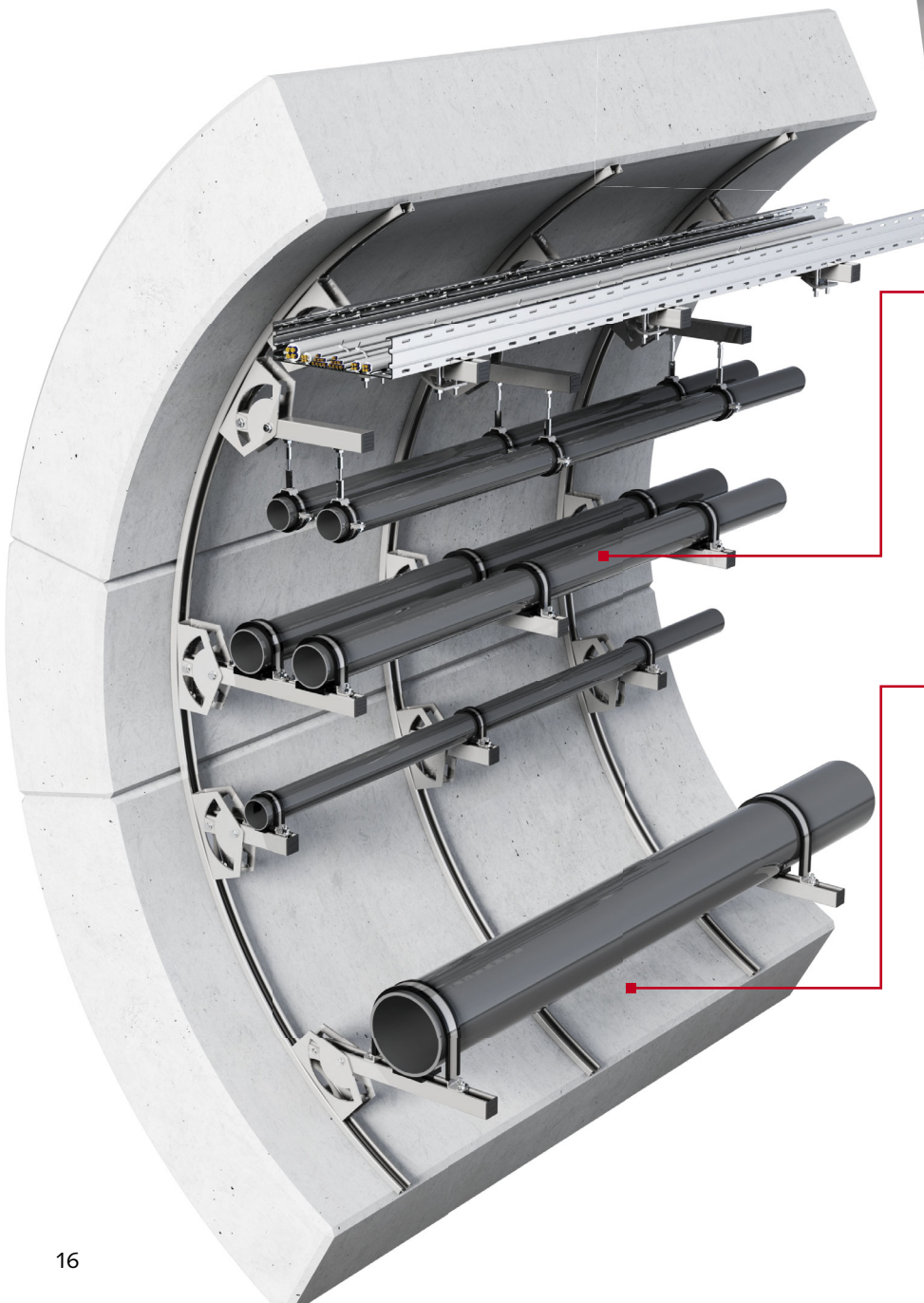

One part for all locations, dramatically reduced complexity

- suitable for pipe clamps, shoes and cable trays
- can be used for laid or suspended pipes
- takes up site tolerance. Cope with changes due to site conditions

No custom cantilevers required, no angles to measure

- simplified design
- no risk of custom cantilevers not fitting
- rapid delivery of stock item = no custom fabrication lead time



HALFEN FLEXIBLE FRAMING CONSTRUCTIONS

System 41 – Medium Duty – Adjustable Cantilever

NEW!

Introduction

The KON 41/V cantilever is freely adjustable from an angle of -56° to $+56^\circ$, and can be fixed to curved cast-in channel or surface-mounted framing channel or directly to the tunnel wall – including curved or inclined surfaces.

KON 41/V is made without welding, and is composed of a HALFEN Framing channel 41/41 cantilever arm and an adjustable HVT rear bracket.

The HVT rear bracket may also be used separately as a fixed support connection element in the HALFEN 41 Framing Channel System to restrain the rotation of a beam, unlike hinge connection elements.

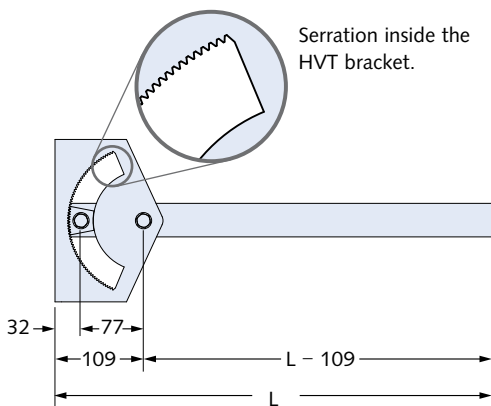
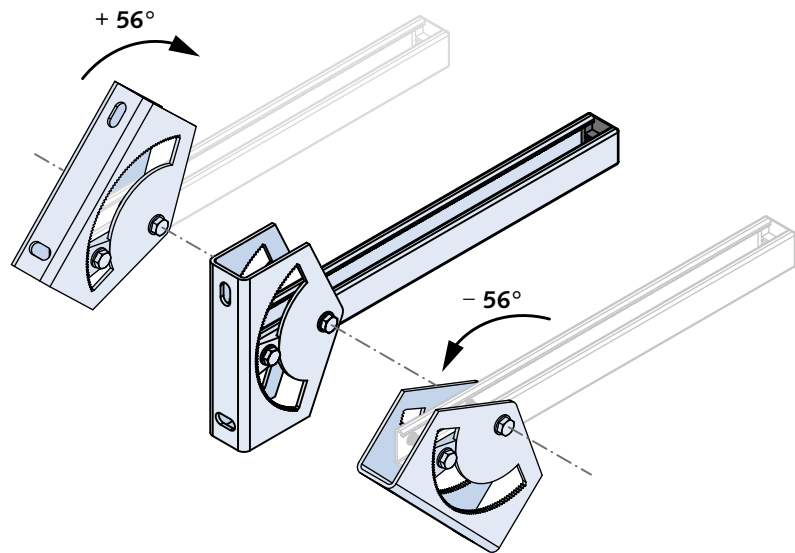

Serration inside the HVT bracket.

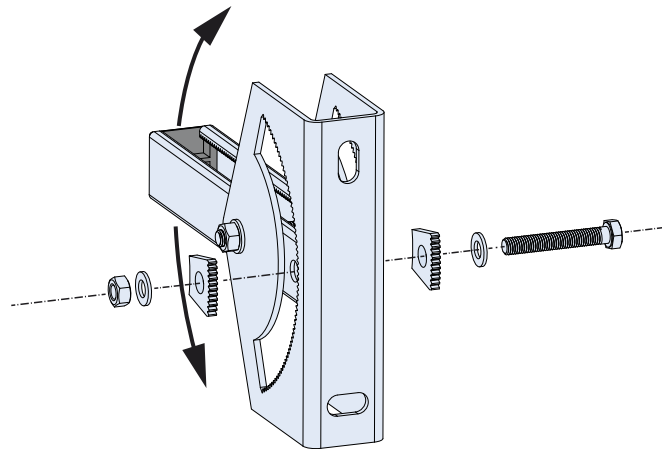

The cantilever is available in three standard lengths. Custom lengths are also available.

The KON 41/V cantilever is easily set to the correct angle by loosening the serration plates. The bracket is set to the required angle, then the assembly is simply re-tightened.

Tried and tested – HALFEN Cast-in or Framing channel with HALFEN Bolts.
The ideal team for fastening in any environment.

For cast-in channels please refer to our catalogue "Technical Product Information HALFEN Cast-in channel".

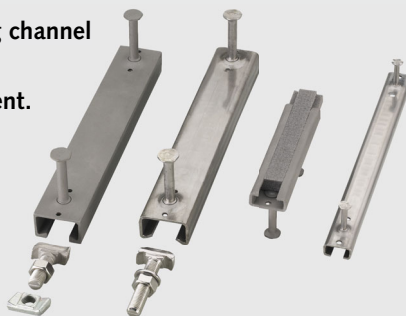

HALFEN FLEXIBLE FRAMING CONSTRUCTIONS

System 41 - Medium Duty - Adjustable Cantilever

NEW!

Cantilever bracket - Type 41/V

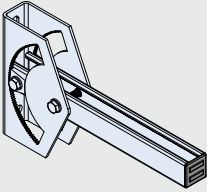
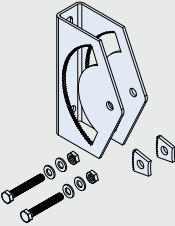
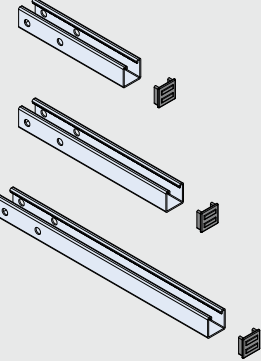
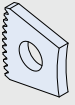
KON 41/V Product overview				
	Order no.	Item name	Item description	
Sets - Assembled				
	0310.300-00001	KON 41/ V FV L=245 mm Adjustable Cantilever. complete, assembled.	Complete set. Fully assembled.	
	0310.300-00002	KON 41/ V FV L=345 mm Adjustable Cantilever. complete, assembled.	Complete set. Fully assembled.	
	0310.300-00003	KON 41/ V FV L=495 mm Adjustable Cantilever. complete, assembled.	Complete set. Fully assembled.	
Components - for assembly				
	0310.310-00001	KON 41/ V- FV Rear bracket set of Adjustable Cantilever - with toothed plates and assembly bolts.	Requires arm for assembly.	
		0310.320-00001	KON 41/ V-FV 245 mm arm only of Adjustable Cantilever	Arm only. Requires rear bracket set for assembly.
		0310.320-00002	KON 41/ V-FV 345 mm arm only of Adjustable Cantilever	Arm only. Requires rear bracket set for assembly.
0310.320-00003		KON 41/ V-FV 495 mm arm only of Adjustable Cantilever	Arm only. Requires rear bracket set for assembly.	
Spares				
	0310.330-00001	KON 41/V- FV spare toothed plate for adjustable cantilever	FV Toothed plate. Single spare, if required	
Components and sets in stainless steel (A4) are available on request				

FV = hot-dip galvanized
A4 = stainless steel

HALFEN FLEXIBLE FRAMING CONSTRUCTIONS

System 41 - Medium Duty - Adjustable Cantilever

NEW!

Cantilever bracket - Type 41/V

KON 41/V

The KON 41/V is the latest addition to the Halfen family of adjustable fixing products, providing the designer with elegant, load-tested solutions, while also giving the contractor a rapid and reliable install, which allows for site tolerances.

A design example is given in the catalogue see page 20-22.

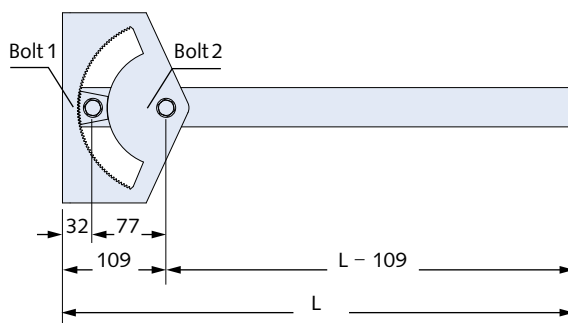
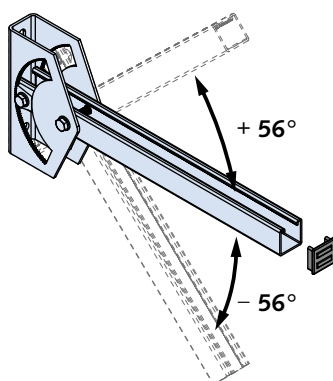

Cantilever disposition [mm]

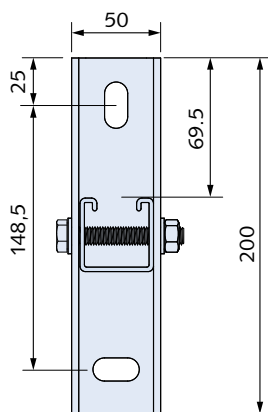

Maximum allowable and design forces

Length L	Load				
[mm]	F [kN]	F_1	F_2	F_3	F_4
257	allow. load	5.55	2.89	2.77	1.85
	F_{Rd}	7.76	4.04	3.88	2.59
357	allow. load	3.44	1.72	1.72	1.15
	F_{Rd}	4.82	2.41	2.41	1.61
507	allow. load	2.15	1.07	1.07	0.72
	F_{Rd}	3.00	1.50	1.50	1.00

Connector reaction forces for the maximum allowable and design forces

Length L	Load				
[mm]	F [kN]	F_1	F_2	F_3	F_4
257	allow. load F_z	6.83	4.99	6.83	6.83
	$F_{z,Rd}$	9.57	6.99	9.57	9.57
	allow. load F_Q	5.55	2.89	5.55	5.55
	$F_{Q,Rd}$	7.76	4.04	7.76	7.76
357	allow. load F_z	5.40	4.14	5.40	5.40
	$F_{z,Rd}$	7.56	5.79	7.56	7.56
	allow. load F_Q	3.44	1.72	3.44	3.44
	$F_{Q,Rd}$	4.82	2.41	4.82	4.82
507	allow. load F_z	4.45	3.66	4.45	4.45
	$F_{z,Rd}$	6.23	5.13	6.23	6.23
	allow. load F_Q	2.15	1.07	2.15	2.15
	$F_{Q,Rd}$	3.00	1.50	3.00	3.00

HALFEN FLEXIBLE FRAMING CONSTRUCTIONS

System 41 - Medium Duty - Adjustable Cantilever

NEW!

KON 41/V Calculation Example

Calculation of the adjustable cantilever KON 41/V is based on the static calculation models as shown in the figures. The example is based on a cantilever with two mounted pipes of different diameter and a cable tray. The example is calculated with design values.

Loads:

$$\begin{aligned} F_{Z,1} &= 0,95 \text{ kN} \\ F_{X,1} &= 0,10 \text{ kN} \\ F_{Z,2} &= 1,90 \text{ kN} \\ F_{X,2} &= 0,20 \text{ kN} \\ q_z &= 1,10 \text{ kN/m} \end{aligned}$$

Design loads:

$$\begin{aligned} F_{Z,1,d} &= 1,4 \cdot F_{Z,1} = 1,33 \text{ kN} \\ F_{X,1,d} &= 1,4 \cdot F_{X,1} = 0,14 \text{ kN} \\ M_{Y,1,d} &= 2,065 \cdot F_{X,1,d} = 0,14 \text{ kNcm} \\ F_{Z,2,d} &= 1,4 \cdot F_{Z,2} = 2,66 \text{ kN} \\ F_{X,2,d} &= 1,4 \cdot F_{X,2} = 0,28 \text{ kN} \\ M_{Y,2,d} &= 2,065 \cdot F_{X,2,d} = 0,58 \text{ kNcm} \\ q_{z,d} &= 1,4 \cdot q_z = 1,54 \text{ kN/m} \end{aligned}$$

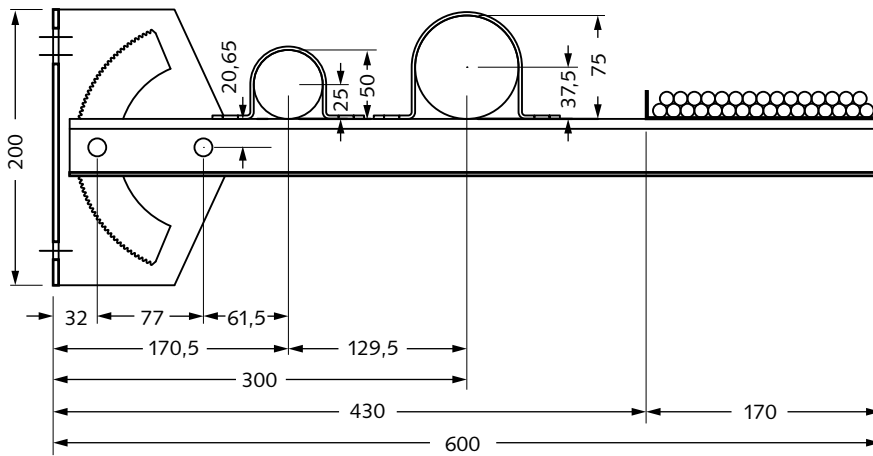

Calculation model 1 for design of:

HZM 41/41 or HM 41/41 profile:

shear forces at infinite distance to bolt 2 from both sides

$$\begin{aligned} V_{Z,Ed}^L &\leq V_{Z,Rd} \\ V_{Z,Ed}^R &\leq V_{Z,Rd} \end{aligned}$$

bending moment above bolt 2, considering shear force on both sides

$$\begin{aligned} M_{Y,Ed} &\leq M_{Y,Rd} \text{ (with } V_{Z,Ed}^L \text{) } \rho \text{ if required} \\ M_{Y,Ed} &\leq M_{Y,Rd} \text{ (with } V_{Z,Ed}^R \text{) } \rho \text{ if required} \end{aligned}$$

normal force on both sides of bolt 2

$$\begin{aligned} N_{Ed}^L &\leq N_{Rd} \text{ (} \rho \text{ if required)} \\ N_{Ed}^R &\leq N_{Rd} \text{ (} \rho \text{ if required)} \end{aligned}$$

Calculation model 1

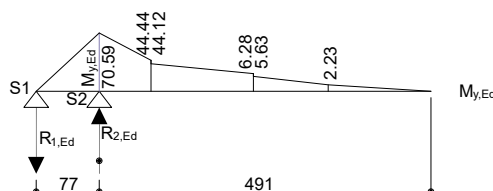
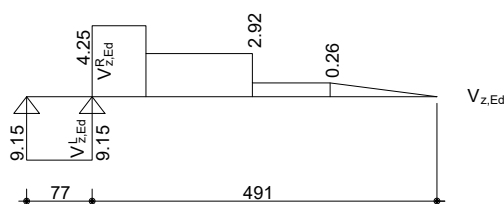
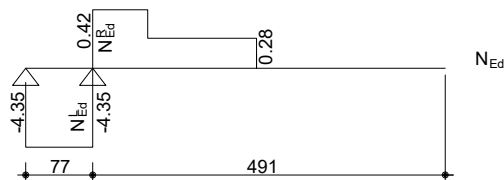
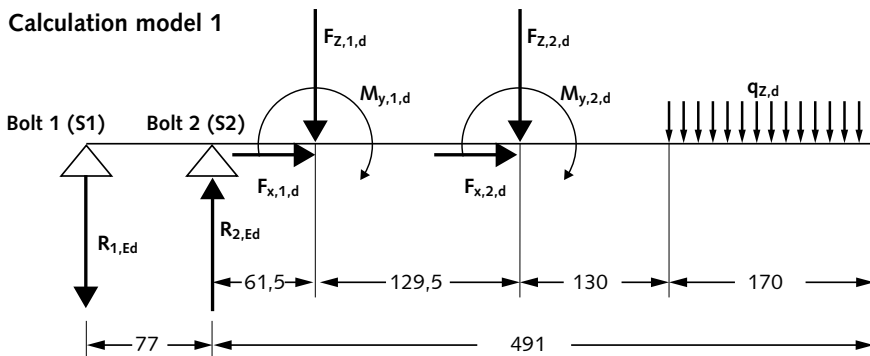

HALFEN FLEXIBLE FRAMING CONSTRUCTIONS

System 41 - Medium Duty - Adjustable Cantilever

NEW!

KON 41/V Calculation Example

HZM or HM 41/41												
Section properties	f_y [N/mm ²]	τ [N/mm ²]	A [cm ²]	Z _c [cm]	I _y [cm ⁴]	I _z [cm ⁴]	Z _p [cm]	W _{pl} [cm ³]	N [kN]	V _Z [kN]	M _y [kNcm]	Deformation
	235.00	135.68	2.688	1.725	7.130	6.887	0.969	3.946	63.16	11.98	69.67	elastic
									63.16	17.08	92.73	plastic

f_y : material yield strength
 τ : material shear strength
 A: section area
 Z_c: ordinate of elastic centroid
 I_y, I_z: bending moment of inertia
 Z_p: ordinate of plastic centroid
 W_{pl}: plastic moment resistance
 el: elastic section forces N_{el}; V_{y,el}; M_{y,el}
 pl: plastic section forces N_{pl}; V_{y,pl}; M_{y,pl}

We provide technical support for planning and calculating of all assembly products. Please refer to your local sales company. Contact information can be found at the end of this catalogue or at www.halfen.com

Calculation model 2

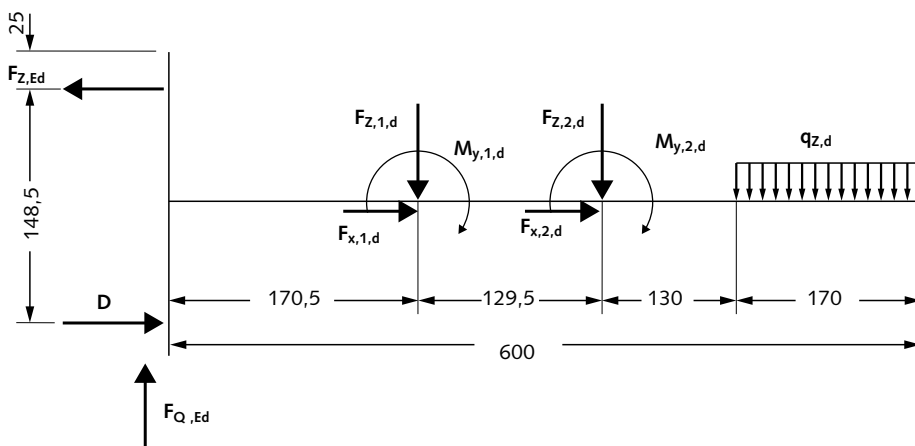

Calculation model 2 for calculation of connector forces:

$$F_{Z,Ed} \leq F_{Z,Rd}$$

$$F_{Q,Ed} \leq F_{Q,Rd}$$

	Allowable forces		Design forces	
	Allowable R ₂ [kN]	Allowable F _Z [kN]	R _{2,d} [kN]	F _{Z,d} [kN]
	12.0	10.7	16.8	15.0

The values are adopted from the tables "maximum forces" and "connector reaction forces" normalization according f_y .

HVT Connector:

According to the first design criteria the following conditions must be verified:

$$R_{2,Ed} \leq R_{2,d} \text{ (for design loads)}$$

$$R_{2,Ed} \leq R_{2,allow.} \text{ (for allowable loads)}$$

HALFEN FLEXIBLE FRAMING CONSTRUCTIONS

HALFEN System 41 – Medium Duty – Adjustable Cantilever

KON 41/V Calculation Example

Example:

From calculation model 2 the connector force $F_{z,Ed}$ can be calculated

Connector force

$$\sum M^+ = q_{z,d} \cdot 0.17 \cdot 51.5 + F_{z,2,d} \cdot 30 + M_{y,2,d} + F_{z,1,d} \cdot 17.05 + M_{y,1,d}$$

$$F_{z,Ed} = \frac{1}{14.85} \cdot \sum M^+ - F_{x,1,d} - F_{x,2,d}$$

$$F_{z,Ed} = 7.45 \text{ kN}$$

Design values for KON 41/V-FV

see table „Section properties“

$$M_{y,Rd} = \frac{M_{y,pl}}{\gamma_m} = \frac{92.73}{1.1} = 84.30 \text{ kN}$$

$$V_{z,Rd} = \frac{V_{z,pl}}{\gamma_m} = \frac{17.08}{1.1} = 15.52 \text{ kN}$$

$$N_{Rd} = \frac{N_{pl}}{\gamma_m} = \frac{63.16}{1.1} = 57.42 \text{ kN}$$

$$R_{2,d} = 16.8 \text{ kN}$$

$$F_{z,d} = 15.0 \text{ kN}$$

Proof of cantilever profile HZM 41/41 left from support S2

$$\frac{V_{z,Ed}^L}{V_{z,Rd}} = \frac{9.15}{15.52} = 0.59 \text{ kN} < 1.0 \quad \checkmark$$

$$V_{z,Ed}^L > 0.5 \cdot V_{z,Rd} \Rightarrow \rho = \left(2 \cdot \frac{V_{z,Ed}^L}{V_{z,Rd}} - 1 \right)^2 = 0.0321 \quad \checkmark$$

$$\frac{M_{y,Ed}}{(1-\rho) \cdot M_{y,Rd}} = \frac{70.59}{(1-0.0321) \cdot 84.3} = 0.865 \text{ kN} < 1.0 \quad \checkmark$$

$$\frac{N_{Ed}^L}{(1-\rho) \cdot N_{Rd}} = \frac{4.35}{(1-0.0321) \cdot 57.42} = 0.078 \text{ kN} < 1.0 \quad \checkmark$$

$$\frac{M_{y,Ed}}{(1-\rho) \cdot M_{y,Rd}} + \frac{N_{Ed}^L}{(1-\rho) \cdot N_{Rd}} = 0.943 \text{ kN} < 1.0 \quad \checkmark$$

Proof of cantilever profile HZM 41/41 right from support S2

$$\frac{V_{z,Ed}^R}{V_{z,Rd}} = \frac{4.25}{15.52} = 0.27 \text{ kN} < 1.0 \quad \checkmark$$

$$V_{z,Ed}^R < 0.5 \cdot V_{z,Rd} \Rightarrow \rho = 0$$

$$\frac{M_{y,Ed}}{M_{y,Rd}} = \frac{70.59}{84.3} = 0.837 \text{ kN} < 1.0 \quad \checkmark$$

$$\frac{N_{Ed}^R}{N_{Rd}} = \frac{0.42}{57.42} = 0.007 \text{ kN} < 1.0 \quad \checkmark$$

$$\frac{M_{y,Ed}}{(1-\rho) \cdot M_{y,Rd}} + \frac{N_{Ed}^R}{(1-\rho) \cdot N_{Rd}} = 0.844 \text{ kN} < 1.0 \quad \checkmark$$

All design criteria are fulfilled by the cantilever profile HZM 41/41

Proof of the HVT 41/V-VK-FV connector

see table „Connector forces“

$$\frac{R_{2,Ed}}{R_{2,d}} = \frac{13.4}{16.8} = 0.79 \text{ kN} < 1.0 \quad \checkmark$$

$$\frac{F_{x,Ed}}{F_{x,d}} = \frac{7.45}{15.0} = 0.50 \text{ kN} < 1.0 \quad \checkmark$$

All design criteria are fulfilled by the connector

HALFEN FLEXIBLE FRAMING CONSTRUCTIONS

HALFEN System 36 – Light Duty

System 36

System 36 is suitable for **light loads** in interior spaces.
The use of optimized support constructions provides an economic and flexible design.

 **HM and HL 36/36**
cold-rolled

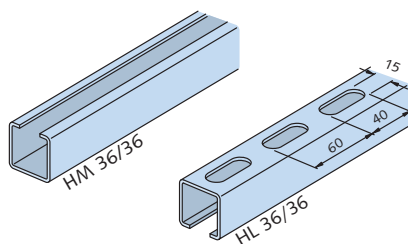
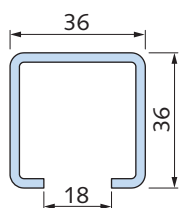

 **HM 38/17**
cold-rolled

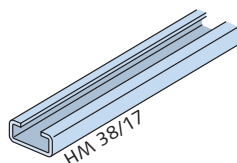
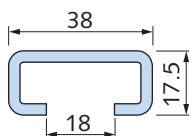

HM 36/36, HL 36/36, HM 38/17		
Material	Order no.	Length [mm]
HM 36/36 0280.		
WB	070-00001	6000
FV	070-00002	
A4	070-00003	
HL 36/36 0281.		
WB	050-00001	6000
FV	050-00002	
A4	050-00003	
HM 38/17 0280.		
WB	020-00001	6070
FV	020-00002	
A2	020-00003	
A4	020-00004	

Channel data, measurements, load bearing capacities, etc. can be found in the Technical Product Information **MT-FBC-E "HALFEN Flexible bolt connections"** (see page 43).

Accessories

PA - 18H Channel cover
HPE 36/36 Channel end cap

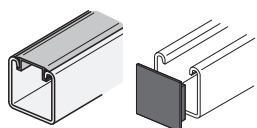

see page 39

SIC 38/17 Locking plate

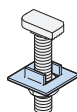

see page 36

SDM 36/6 Vibration absorber

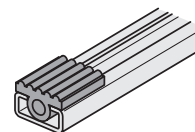

see page 38

 HALFEN Bolt **HS 38/17**
Locking plate **GWP 38/17**

Bolt data, measurements, load bearing capacities, etc. can be found in the Technical Product Information **"HALFEN Flexible bolt connections"** (see page 44).

HALFEN FLEXIBLE FRAMING CONSTRUCTIONS

HALFEN System 36 - Light Duty

Application examples



Connection fittings HVT 36

Standard dimensions [mm]:

Unless otherwise stated, all HVT 36 connectors are made with the following typical dimensions:

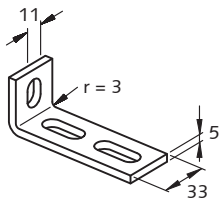

Recommended HALFEN Bolts:

HS 38/17 M10 x 30 FV 4.6 or A4-70
 HS 38/17 M12 x 30 FV 4.6 or A4-70
 and washers.

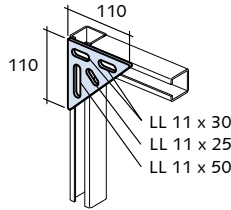

HVT 36-1

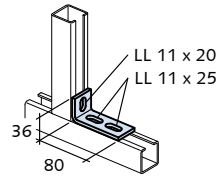

HVT 36-2

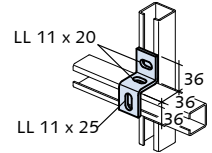

HVT 36-3

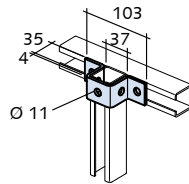

HVT 36-4

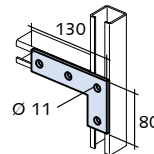

HVT 36-5

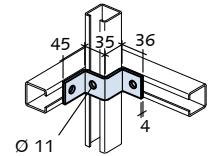

HVT 36-6

Connection elements - System 36

Article name	Order no.	
	FV = hot-dip galvanized GV = electro-plated	A4 = stainless steel
	0312.020-	0312.020
HVT 36 - 1 - GV	00001	-
HVT 36 - 2 - GV	00002	00010
HVT 36 - 3 - GV	00003	-
HVT 36 - 4 - GV	00004	-
HVT 36 - 5 - GV	00005	-
HVT 36 - 6 - GV	00006	-
HVT 36 - 7 - FV	00007	00011
HVT 36 - 8 - GV	00008	-
HVT 36 - 9 - FV	00009	-

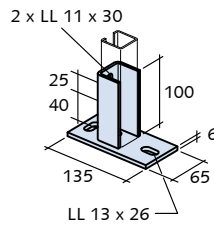

HVT 36-7

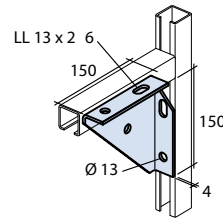

HVT 36-8

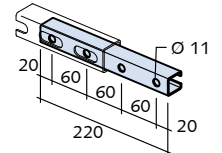

HVT 36-9 ①

Note: Each drawing shows only one of many possible applications.

① The connector is fixed to channels with T-head bolts type HS 28/15 - M10 x 25 and washers M10 DIN EN ISO 7093-1/ DIN 9021.

HALFEN FLEXIBLE FRAMING CONSTRUCTIONS

HALFEN System 28 - Light Duty

System 28

Similar to System 36, System 28 is also suitable for **light loads** in interior environments.

 **HM and HL 28/28**
cold-rolled

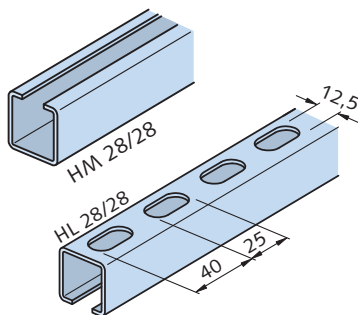
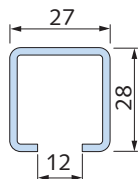

HM 28/28 and HL 28/28		
Material	Order no.	Length [mm]
HM 28/28 0280.		
WB	050-00001	6000
SV	050-00003	
FV	050-00002	
A4	050-00004	
HL 28/28 0281.		
WB	060-00001	6000
SV	060-00003	
FV	060-00002	
A4	060-00004	

Accessories

HPE 28/28 Channel end cap

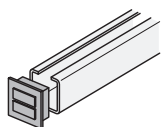

see page 39

SDM 28/6 Vibration absorber

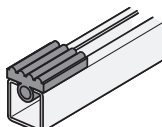

see page 38

Channel data, measurements, load bearing capacities, etc. can be found in the Technical Product Information "HALFEN Flexible bolt connections" (see page 47).

 **HALFEN Bolt HS 28/15**
Locking plate **GWP 28/15**

Bolt data, measurements, load bearing capacities, etc. can be found in the Technical Product Information "HALFEN Flexible bolt connections" (see page 58).

Connection fittings HVT 28

Standard dimensions [mm]:

Unless otherwise stated, all **HVT 28** connectors are made with the following typical dimensions:

Recommended HALFEN Bolts:
HS 28/15 - M8 x 20
and washers.

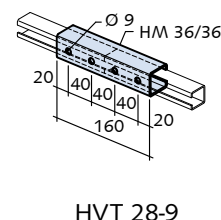
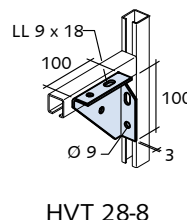
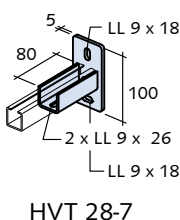
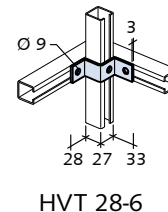
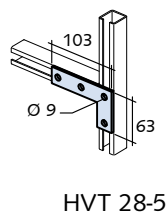
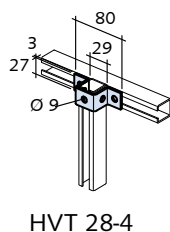
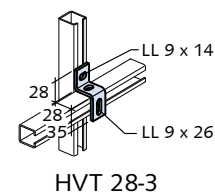
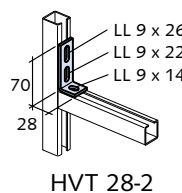
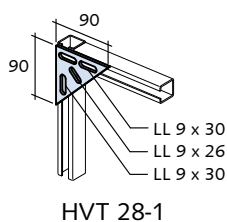
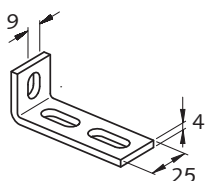

Fitting system HVT 28	
FV = hot-dip galvanized GV = zinc plated	Order no.
	0312.010-
HVT 28 - 1 - GV	00001
HVT 28 - 2 - GV	00002
HVT 28 - 3 - GV	00003
HVT 28 - 4 - GV	00004
HVT 28 - 5 - GV	00005
HVT 28 - 6 - GV	00006
HVT 28 - 7 - FV	00007
HVT 28 - 8 - GV	00008
HVT 28 - 9 - FV	00009

HALFEN FLEXIBLE FRAMING CONSTRUCTIONS

HALFEN System 36 and System 28 – Light Duty – Construction Example

Framework constructions

Pre-assembled Components; System 36 and System 28

HALFEN System 36 and System 28 are used in support structures for pipes with small nominal diameter and cable-trays, i.e. supply modules in apparatus engineering.

Example: Ground supports connected to plant components

Delivery time on request.

Construction example System 36:

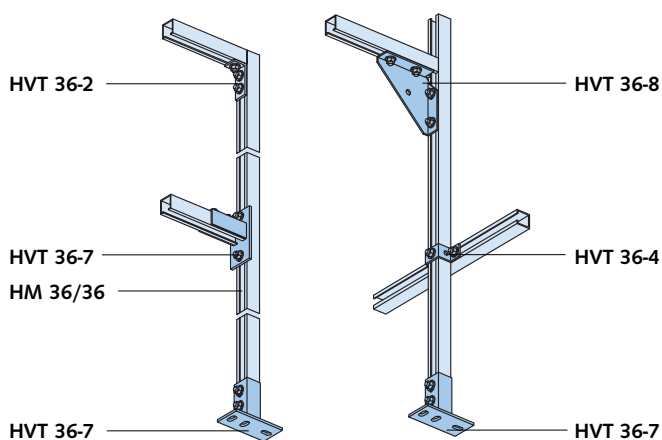
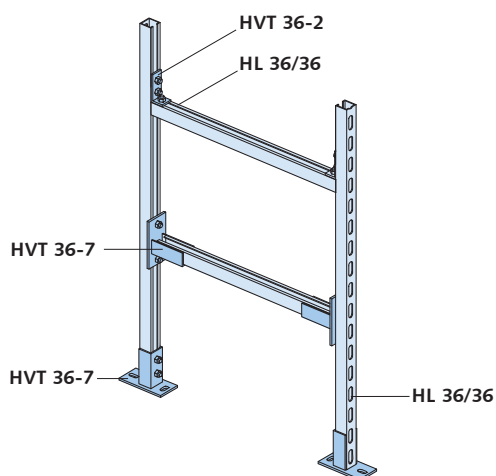

Construction example System 28:

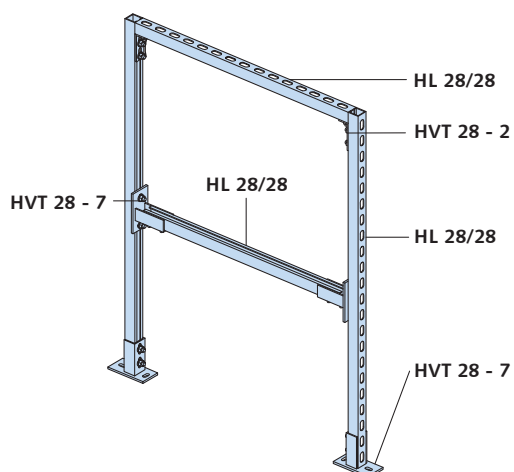

Frame constructions are made to customer specifications, supported by our engineering team and made, including assembly material, by our production team.

If you have any further questions:

Our technical department and our field support technicians will gladly advise and support you with solutions when using HALFEN Framing systems.

For more information please contact us

Please see the back page of this catalogue for regional contact addresses.
www.halfen.com

HALFEN FLEXIBLE FRAMING CONSTRUCTIONS

Cantilever Brackets

HALFEN Cantilever brackets

Cantilevers constructed in standard HALFEN Channel profiles can be combined with HALFEN T-head bolts, HALFEN Fittings and numerous system accessories as required.

Note: Depending on the number of items ordered, cantilever brackets can also be made to customer specifications.

Bracket 52:

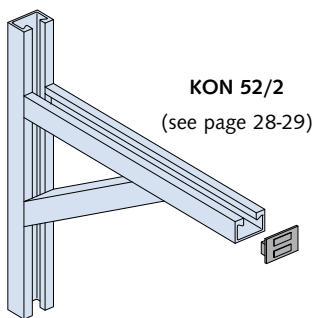

Bracket 41:

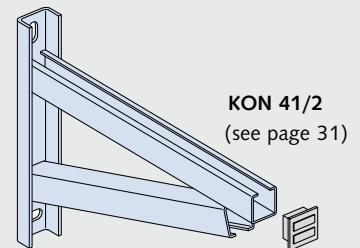
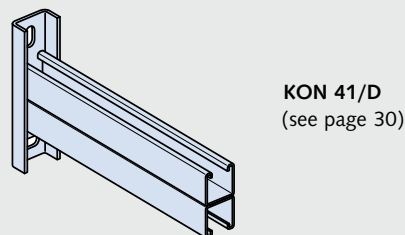
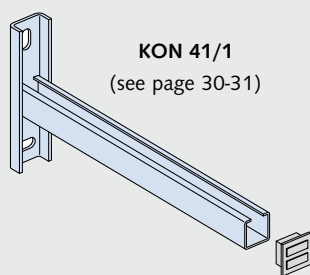

Bracket 36/28:

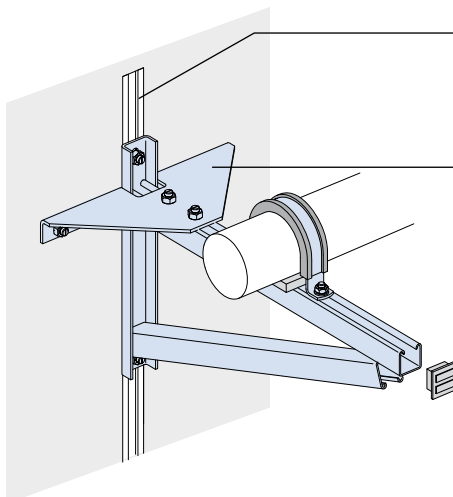
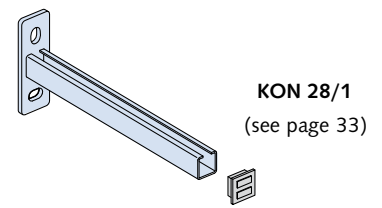
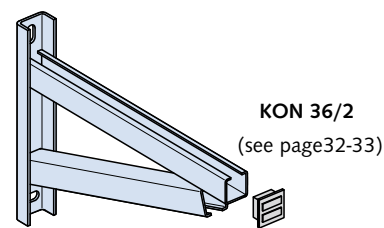
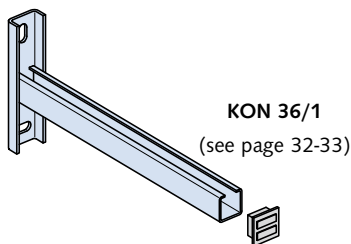

Fixing with dowel to wall or with T-head bolts to HALFEN Cast-in channel.

For loads in longitudinal pipe direction combinations of HALFEN Cantilevers with support brace type KON - Z1 are possible.

All HALFEN Cantilever brackets are delivered with channel end cap (except KON 41/D).

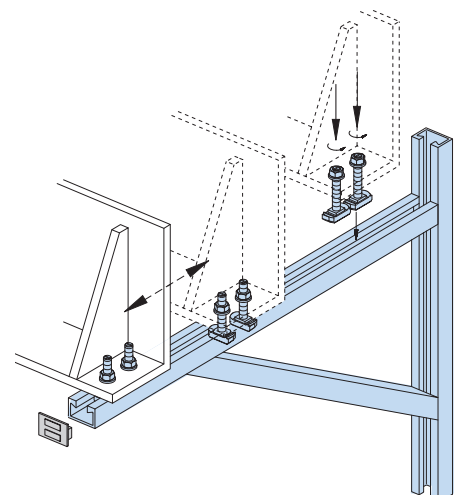

HALFEN FLEXIBLE FRAMING CONSTRUCTIONS

Cantilever Brackets

Cantilever brackets - Type 52

KON 52/2 

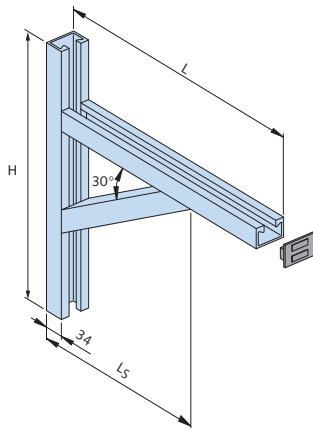

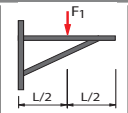
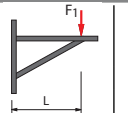
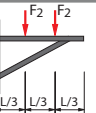
Dimensions and load bearing capacities KON 52/2								
Length L [mm]	Height H [mm]	Length L ₅ [mm]	hot-dip galvanized FV Order no. 0310.080-	stainless steel A4 ① Order no. 0310.080-	F [kN] ②			
						F ₁	F ₁	F ₂
500	450	330	00001	00008	allow. load	9.0	15.0	7.5
					F _{Rd}	12.6	21.0	10.5
600	475	380	00002	00009	allow. load	8.0	15.0	7.5
					F _{Rd}	11.2	21.0	10.5
700	500	430	00003	00010	allow. load	7.0	15.0	6.5
					F _{Rd}	9.8	21.0	9.1
800	550	480	00004	00011	allow. load	6.0	15.0	6.0
					F _{Rd}	8.4	21.0	8.4
900	600	530	00005	00012	allow. load	5.5	15.0	5.5
					F _{Rd}	7.7	21.0	7.7
1000	650	630	00006	00013	allow. load	5.0	15.0	5.0
					F _{Rd}	7.0	21.0	7.0
1100	700	730	00007	00014	allow. load	4.5	14.0	4.5
					F _{Rd}	6.3	19.6	6.3

① on request ② Explanatory notes for verification, see page 5

KON 52/2 Assembly

For lateral bracing please use KON 52/3 and KON 52/4

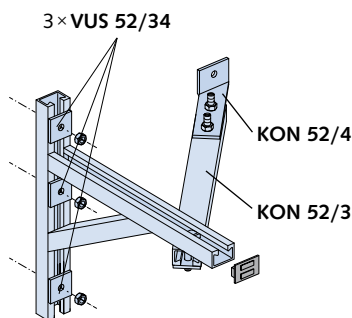
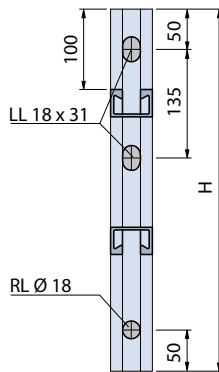

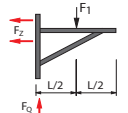
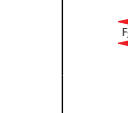
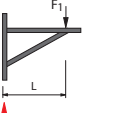
Connection forces KON 52/2							
Length L [mm]	① F [kN]						
		Z	Q	Z	Q	Z	Q
500	allow. load	6.3	9.1	14.4	15.1	10.7	15.1
	F _{Rd(...)}	8.8	12.7	20.0	21.1	14.8	21.1
600	allow. load	6.0	8.1	14.1	15.1	11.4	15.1
	F _{Rd(...)}	8.3	11.3	19.5	21.1	15.8	21.1
700	allow. load	5.5	7.1	14.0	15.1	10.3	13.1
	F _{Rd(...)}	7.5	10.0	19.3	21.2	14.3	18.4
800	allow. load	4.8	6.1	13.9	15.1	9.8	12.1
	F _{Rd(...)}	6.7	8.6	19.2	21.2	13.6	17.0
900	allow. load	4.5	5.6	13.8	15.1	9.3	11.1
	F _{Rd(...)}	6.3	7.9	19.1	21.2	12.9	15.6
1000	allow. load	4.4	5.2	13.7	15.2	8.9	10.2
	F _{Rd(...)}	6.1	7.2	18.9	21.2	12.3	14.2
1100	allow. load	4.3	4.7	12.7	14.2	8.5	9.2
	F _{Rd(...)}	5.9	6.5	17.5	19.8	11.8	12.8

① Explanatory notes for verification, see page 5

HALFEN FLEXIBLE FRAMING CONSTRUCTIONS

Cantilever Brackets

Cantilever bracket – 52; continued

Fittings for bracket 52/2

Bracing KON 52/3

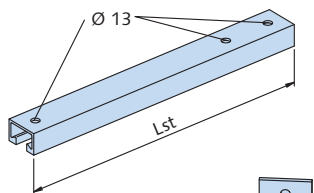

Fixing bracket KON 52/4

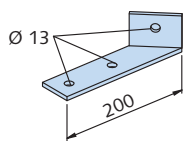

Dimensions KON 52/3 and KON 52/4 ②						
	Length	hot-dip galvanized FV	stainless steel A4 ①	suitable for bracket 52/2		
	L _{St} [mm]	Order no. 0310.	Order no. 0310.	Length L [mm]	r [mm]	A [mm]
KON 52/3	532	090-00001	090-00012	500	100	400
	602	090-00002	090-00013	600	150	450
	673	090-00003	090-00014	700	200	500
	744	090-00004	090-00015	800	250	550
	815	090-00005	090-00016	900	300	600
	961	090-00006	090-00017	1000	300	700
	1102	090-00007	090-00018	1100	300	800
KON 52/4		100-00002	100-00001	-	-	-

① on request

Assembly diagram for lateral bracing

HS 50/30 - M12 × 60
incl. nut ②

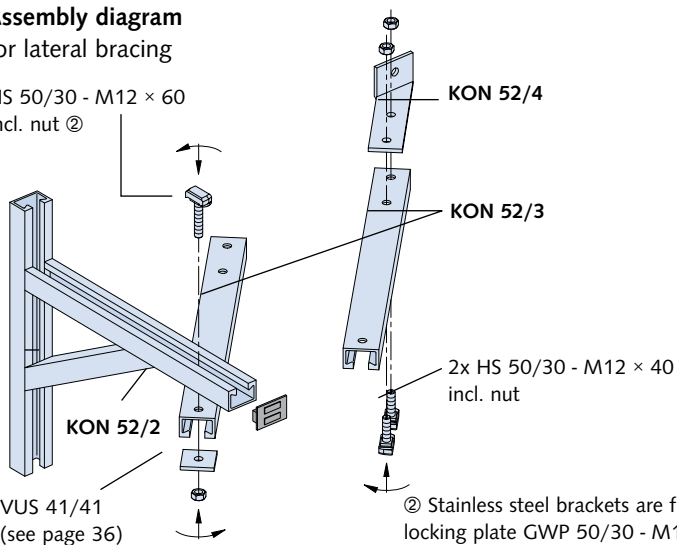

VUS 41/41
(see page 36)

② Stainless steel brackets are fixed with locking plate GWP 50/30 - M12 and hexagonal bolt HSK - M12 × 60, DIN 933.

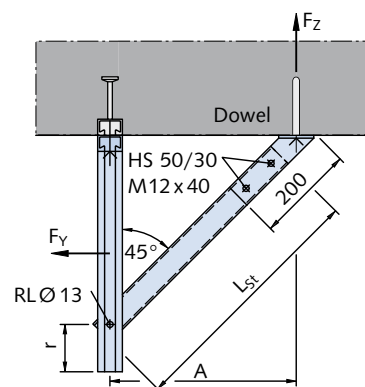

Note: The max. possible load of lateral braces depends on the allowable load (F_z) of the dowels.

HALFEN FLEXIBLE FRAMING CONSTRUCTIONS

Cantilever Brackets



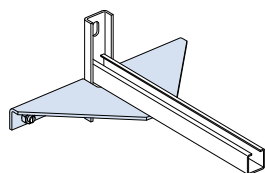
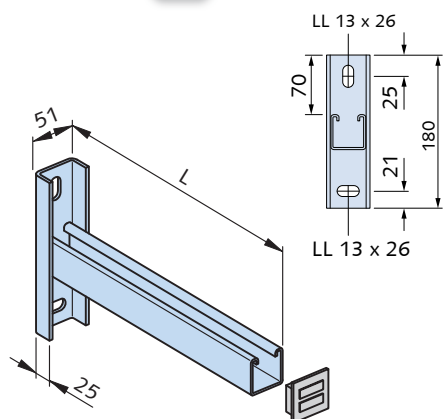

Cantilever bracket - Type 41

KON 41/1 



Assembly example with bracing KON Z1 (see page 31)

Dimensions and load bearing capacities KON 41/1

Length L [mm]	hot-dip galvanized FV Order no. 0310.010-	stainless steel A4 Order no. 0310.010-	F [kN] ①				
				F ₁	F ₁	F ₂	F ₃
175	00001	00004	allow. load	5.35	2.65	2.65	1.75
			F _{Rd}	7.49	3.71	3.71	2.45
325	00002	00005	allow. load	2.65	1.30	1.30	0.85
			F _{Rd}	3.71	1.82	1.82	1.19
475	00003	00006	allow. load	1.75	0.85	0.85	0.55
			F _{Rd}	2.45	1.19	1.19	0.77

① Explanatory notes for verification, see page 5

Connection force KON 41/1

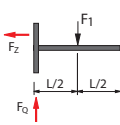
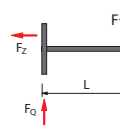
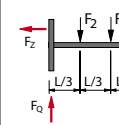
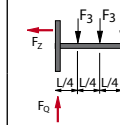
Length L [mm]	F [kN] ①								
		Z	Q	Z	Q	Z	Q	Z	Q
175	allow. load	3.5	5.4	3.5	2.7	3.5	5.4	3.5	5.3
	F _{Rd(...)}	4.9	7.5	4.9	3.8	4.9	7.5	4.8	7.4
325	allow. load	3.3	2.7	3.2	1.4	3.2	2.7	3.1	2.6
	F _{Rd(...)}	4.6	3.8	4.5	1.9	4.5	3.7	4.4	3.6
475	allow. load	3.2	1.8	3.1	0.9	3.1	1.8	3.0	1.7
	F _{Rd(...)}	4.4	2.5	4.3	1.3	4.3	2.4	4.2	2.4



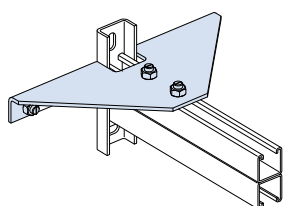
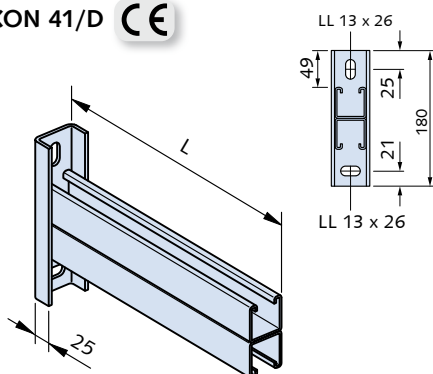

① Explanatory notes for verification, see page 5

KON 41/D 



Assembly example with bracing KON Z1 (see page 31)

Dimensions and load bearing capacities KON 41/D

Length L [mm]	hot-dip galvanized FV Order no. 0310.030-	stainless steel A4 Order no. 0310.030-	F [kN] ①				
				F ₁	F ₁	F ₂	F ₃
325	00001	00004	allow. load	5.60	2.80	2.80	1.85
			F _{Rd}	7.84	3.92	3.92	2.59
475	00002	00005	allow. load	3.70	1.85	1.85	1.20
			F _{Rd}	5.18	2.59	2.59	1.68
625	00003	00006	allow. load	2.80	1.40	1.40	0.90
			F _{Rd}	3.92	1.96	1.96	1.26

① Explanatory notes for verification, see page 5

HALFEN FLEXIBLE FRAMING CONSTRUCTIONS

Cantilever Brackets

Cantilever bracket- Type 41

Connection forces KON 41/D

Connection force KON 41/D

Length L [mm]	① F [kN]								
		Z	Q	Z	Q	Z	Q	Z	Q
325	allow. load	6.9	5.7	6.9	2.9	6.9	5.7	6.8	5.6
	$F_{Rd(...)}$	9.6	7.9	9.6	4.0	9.6	7.9	9.5	7.8
475	allow. load	6.6	9.3	6.6	1.9	6.6	3.8	6.5	3.7
	$F_{Rd(...)}$	3.8	5.3	9.3	2.7	9.3	5.3	9.0	5.1
625	allow. load	6.7	2.9	6.7	1.5	6.7	2.9	6.4	2.8
	$F_{Rd(...)}$	9.3	4.0	9.3	2.1	9.3	4.0	9.0	3.9

① Explanatory notes for verification, see page 5

KON 41/2

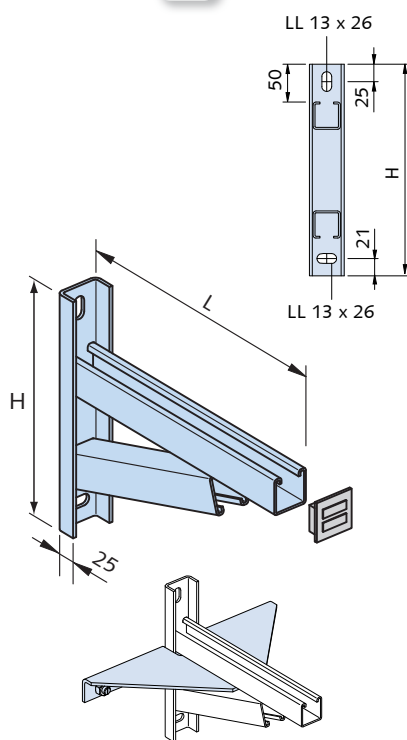

Assembly example with bracing KON Z1 (see below)

Dimensions and load bearing capacities KON 41/2

Size [mm]	hot-dip galvanized FV	stainless steel A4	Order no.	Order no.	F [kN] ①				
						F ₁	F ₁	F ₂	F ₃
325	0310.020-	0310.020-	00001	00005	allow. load	7.50	4.90	4.80	3.40
					F_{Rd}	10.50	6.86	6.72	4.76
475	00002	00006	00002	00006	allow. load	5.00	4.75	3.70	2.45
					F_{Rd}	7.00	6.65	5.18	3.43
625	00003	00007	00003	00007	allow. load	3.50	3.50	2.75	1.85
					F_{Rd}	4.90	4.90	3.85	2.59
775	00004	00008	00004	00008	allow. load	2.65	2.65	2.05	1.40
					F_{Rd}	3.71	3.71	2.87	1.96

① Explanatory notes for verification, see page 5

Connection force KON 41/2

Length L [mm]	① F [kN]								
		Z	Q	Z	Q	Z	Q	Z	Q
325	allow. load	5.5	7.6	6.8	4.9	7.0	9.7	7.5	10.3
	$F_{Rd(...)}$	7.7	10.6	9.6	6.9	9.9	13.5	10.5	14.4
475	allow. load	4.2	5.1	7.6	4.8	6.3	7.5	6.2	7.4
	$F_{Rd(...)}$	6.0	7.1	10.8	6.7	8.8	10.5	8.8	10.4
625	allow. load	3.4	3.6	6.3	3.6	5.2	5.6	5.3	5.6
	$F_{Rd(...)}$	4.7	5.0	9.0	5.0	7.4	7.8	7.4	7.9
775	allow. load	2.8	2.7	5.2	2.7	4.2	4.2	4.3	4.3
	$F_{Rd(...)}$	3.9	3.8	7.3	3.8	6.0	5.9	6.1	6.0

① Explanatory notes for verification, see page 5

Accessory: Bracket KON Z1 for the cantilevers KON 41, KON 36, and KON 28

hot-dip galvanized FV	stainless steel A4
Order no.	Order no.
0310.110-00002	0310.110-00001
Bolts for KON Z1	
KON 28	HS 28/15 M10 x 30 fv
KON 36	HS 38/17 M12 x 30 fv
KON 41	HS 41/41 M12 x 35 fv

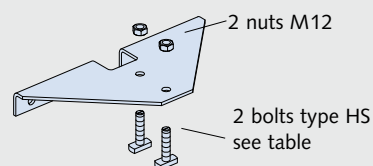
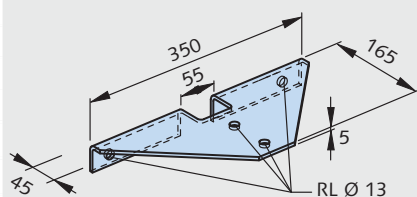

(bolts, nuts and brackets are ordered separately)

HALFEN FLEXIBLE FRAMING CONSTRUCTIONS

Cantilever Brackets

Cantilever bracket - Type 36

KON 36/1 

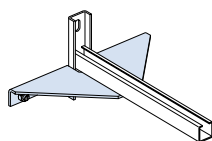
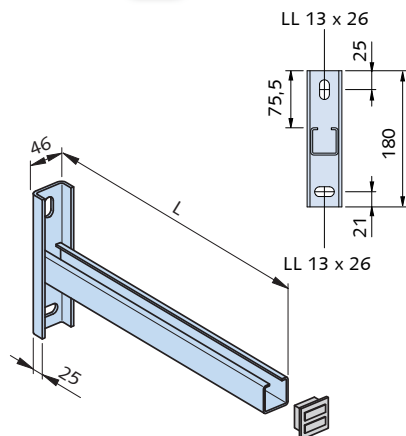

Assembly example with bracing KON Z1 (see page 31)

Dimensions and load bearing capacities KON 36/1

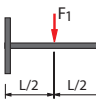
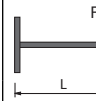
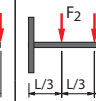
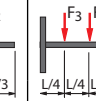
Length L [mm]	hot-dip galvanized FV Order no. 0310.060-	stainless steel A4 Order no. 0310.060-	F [kN] ①				
				F ₁	F ₁	F ₂	F ₃
300	00001	00005	allow. load	2.00	1.00	1.00	0.67
			F _{Rd}	2.80	1.40	1.40	0.98
400	00002	00006	allow. load	1.50	0.75	0.75	0.50
			F _{Rd}	2.10	1.05	1.05	0.70
500	00003	00007	allow. load	1.20	0.60	0.60	0.40
			F _{Rd}	1.68	0.84	0.84	0.56
600	00004	00008	allow. load	1.00	0.50	0.50	0.33
			F _{Rd}	1.40	0.70	0.70	0.46

① Explanatory notes for verification, see page 5

Connection force KON 36/1

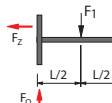
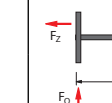
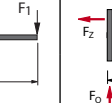
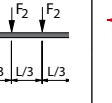
Length L [mm]	F [kN] ①								
		Z	Q	Z	Q	Z	Q	Z	Q
300	allow. load	3.4	2.0	3.5	1.0	3.3	2.0	3.5	2.2
	F _{Rd,(...)}	4.7	2.8	4.9	1.4	4.6	2.8	4.9	3.0
400	allow. load	3.4	1.6	3.6	0.8	3.4	1.6	3.4	1.6
	F _{Rd,(...)}	4.8	2.2	5.0	1.1	4.8	1.6	4.8	2.2
500	allow. load	3.5	1.3	3.6	0.7	3.5	1.3	3.5	1.3
	F _{Rd,(...)}	4.9	1.7	5.0	0.9	4.9	1.7	4.9	1.7
600	allow. load	3.6	1.0	3.6	0.5	3.6	1.0	3.6	1.0
	F _{Rd,(...)}	5.0	1.4	5.1	0.7	5.0	1.4	4.9	1.4

① Explanatory notes for verification, see page 5

KON 36/2 

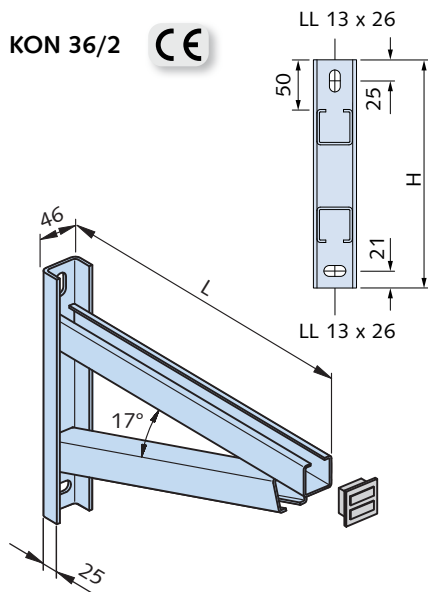

Dimensions and load bearing capacities KON 36/2

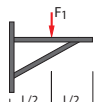
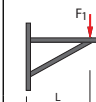
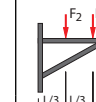
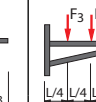
Length L [mm]	hot-dip galvanized FV Order no. 0310.070-	stainless steel A4 Order no. 0310.070-	F [kN] ①				
				F ₁	F ₁	F ₂	F ₃
300	00001	00006	allow. load	5.00	3.20	3.60	2.35
			F _{Rd}	7.00	4.40	5.00	3.30
400	00002	00010	allow. load	4.15	2.75	3.15	2.10
			F _{Rd}	5.80	3.85	4.40	2.95
500	00003	00007	allow. load	3.15	2.70	2.50	1.65
			F _{Rd}	4.40	3.80	3.50	2.30
600	00004	00009	allow. load	2.55	2.50	2.00	1.30
			F _{Rd}	3.60	3.50	2.80	1.80
700	00005	00011	allow. load	2.10	2.50	1.65	1.10
			F _{Rd}	2.95	3.50	2.30	1.55

① Explanatory notes for verification, see page 5

HALFEN FLEXIBLE FRAMING CONSTRUCTIONS

Cantilever Brackets

Cantilever bracket - Type 36

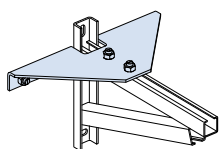

Assembly example with bracing KON Z1 (see page 31)

Connection force KON 36/2									
Length L [mm]	F [kN] ①	F ₁		F ₂		F ₂		F ₃	
		F _Z	F _Q	F _Z	F _Q	F _Z	F _Q	F _Z	F _Q
300	allow. load	4.9	5.0	5.6	3.1	6.7	7.2	6.4	7.1
	F _{Rd,(...)}	6.9	7.0	7.9	4.4	9.4	10.1	8.9	9.9
400	allow. load	5.2	4.2	6.2	2.8	7.3	6.3	7.1	6.3
	F _{Rd,(...)}	7.3	5.8	8.7	3.9	10.2	8.9	9.9	8.9
500	allow. load	4.9	3.2	7.1	2.7	7.1	5.0	6.7	5.0
	F _{Rd,(...)}	6.8	4.5	9.9	3.8	9.9	7.0	9.4	7.0
600	allow. load	4.6	2.6	7.3	2.5	6.6	4.0	6.1	3.9
	F _{Rd,(...)}	6.4	3.6	10.2	3.5	9.3	5.7	8.6	5.5
700	allow. load	4.4	2.1	8.2	2.6	6.3	3.3	5.9	3.3
	F _{Rd,(...)}	6.1	3.0	11.5	3.6	8.8	4.7	8.3	4.7

① Explanatory notes for verification, see page 5

Cantilever bracket - Type 28

KON 28/1

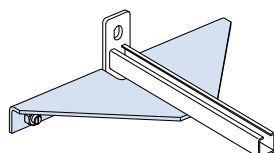
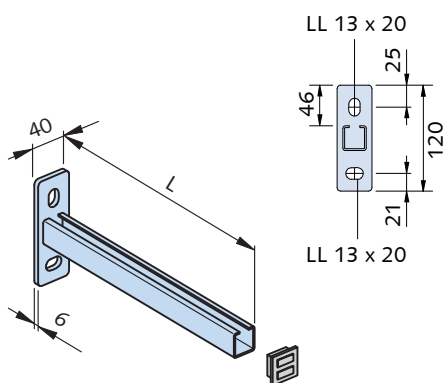

Assembly example with bracing KON Z1 (see page 31)

Dimensions and load bearing capacities KON 28/1									
Length L [mm]	hot-dip galvanized FV Order no. 0310.050-	stainless steel A4 Order no. 0310.050-	F [kN] ①	F ₁		F ₂		F ₃	
				F _Z	F _Q	F _Z	F _Q	F _Z	F _Q
100	00001	00005	allow. load	2.70	1.35	1.35	0.90		
			F _{Rd}	3.78	1.89	1.89	1.26		
200	00002	00006	allow. load	1.35	0.68	0.68	0.45		
			F _{Rd}	1.89	0.95	0.95	0.63		
300	00003	00007	allow. load	0.90	0.45	0.45	0.30		
			F _{Rd}	1.26	0.63	0.63	0.42		
400	00004	00008	allow. load	0.70	0.35	0.35	0.20		
			F _{Rd}	0.98	0.49	0.49	0.28		

① Explanatory notes for verification, see page 5

Connection force KON 28/1									
Length L [mm]	F [kN] ①	F ₁		F ₂		F ₂		F ₃	
		F _Z	F _Q	F _Z	F _Q	F _Z	F _Q	F _Z	F _Q
100	allow. load	1.9	2.7	1.9	1.4	1.9	2.7	1.9	2.7
	F _{Rd,(...)}	2.6	3.8	2.6	1.9	2.6	3.8	2.6	3.8
200	allow. load	1.9	1.4	1.9	0.7	1.9	1.4	1.9	1.4
	F _{Rd,(...)}	2.6	1.9	2.6	1.0	2.6	2.0	2.6	1.9
300	allow. load	1.9	1.0	1.9	0.5	1.9	1.0	1.9	1.0
	F _{Rd,(...)}	2.6	1.3	2.6	0.7	2.6	1.3	2.6	1.3
400	allow. load	1.9	0.8	1.9	0.4	1.9	0.8	1.7	0.7
	F _{Rd,(...)}	2.7	1.0	2.7	0.5	2.7	1.0	2.3	0.9

① Explanatory notes for verification, see page 5

HALFEN FLEXIBLE FRAMING CONSTRUCTIONS

Adjustable Framework Construction – Accessories

Beam clamp – HCS TK

HCS TK
Beam clamp

Beam clamp with "Grip".
form-fit load transmission with 4 nibs,
used in pairs.
Adjustable flange height 5–40 mm.

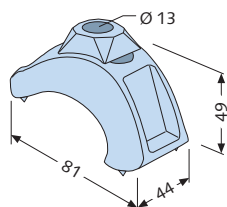

Assembly diagram

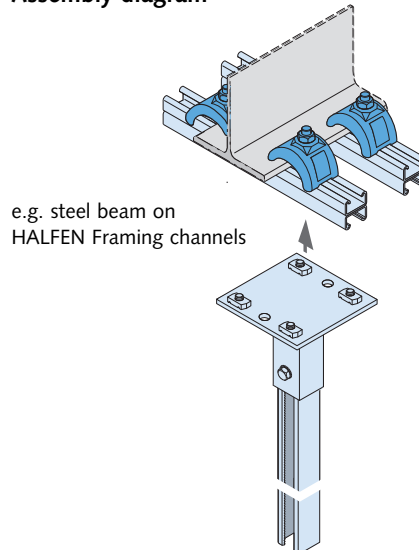

e.g. steel beam on
HALFEN Framing channels

Beam clamps – HCS TK	
Type	Order no.
hot-dip galvanized	
HCS TK - FV	0308.030-00001

Please order HALFEN Bolts and nuts
separately. The torque value depends
on the bolts used.

Beam clamp – KLP-S

KLP - S
Beam clamps, S235 forged steel

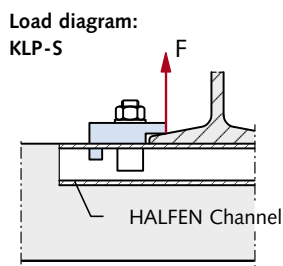
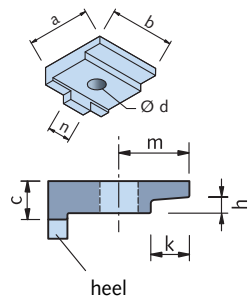

Assembly diagram KLP - S

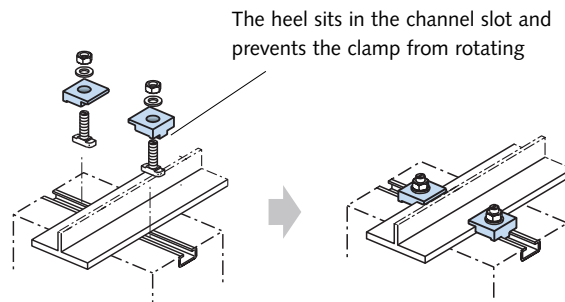

The heel sits in the channel slot and
prevents the clamp from rotating

Dimensions and load bearing capacities – KLP-S

Type no.	FV hot-dip galvanized Order no.	heel width n [mm]	for HALFEN-Bolts $\varnothing \times l$ [mm]	Dimensions [mm]							allow. load at σ allow. = 125 N/mm ² F [kN]	used mainly with		
				a	b	c	$\varnothing d$	h	k	m		europaean standard beams l	other beam, flange thickness t [mm]	Railtracks- [Ⓢ] crane-rails etc. nominal size (acc. DIN 536)
10	00001	16	M 16 x 60	44	45	12	$\varnothing 18$	5	12	22	3.5	80 - 140	4 - 6	S 24
26	00002	no heel	M 16 x 60	62.5	64	21	$\varnothing 18$	9	16.5	34.5	3.5	160 - 240	7 - 9	S 24 A 45, A 55
20	00003	20	M 20 x 65	52	55	19	$\square 21$	8	15.0	24	10.0	160 - 240	7 - 9	S 24 - S 49

Ⓢ Check flange thickness of the rail.

HALFEN FLEXIBLE FRAMING CONSTRUCTIONS

Adjustable Framework Construction – Accessories

Beam clamps – KLP 60

KLP - 60 Beam clamps

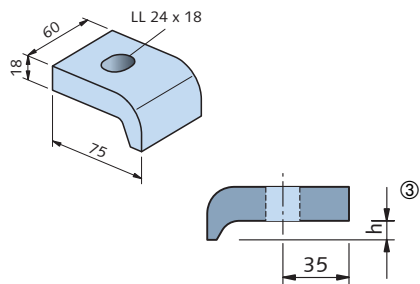

Dimensions and load bearing capacities – KLP - 60							
Type	FV hot-dip galvanized	Clamping height h [mm]	allowable load ^②		used mainly with		
	Order no.		HALFEN HS Bolts to suit selected channel M 16 × 60	Standard profiles I	Standard profiles HEB (IPB)	Railtracks- ^③ crane-rails etc. nominal size (acc. to DIN 536)	
	0325.020-		bolt, grade 4.6	bolt, grade 8.8			
60/10	00001	10	F ₁ = 7,0	F ₂ = 11,25	120 - 160	A65, S 33, S 41	
60/12	00002	12			220 - 240	100	A100, S 49, A75
60/14	00003	14			240 - 280	140	A120, S 54
60/16	00004	16			300 - 340	160 - 180	S 64
60/18	00005	18 ^①			360 - 380	200 - 220	-
60/20	00006	20 ^①			400 - 450	240 - 260	-
					280 - 300	-	

^① T-head bolt M16 × 80 is required (bolt length depends on clamping height and channel type).
^② Do not exceed HALFEN Framing channel bearing capacity! (The effect of the cantilever must be considered when selecting HALFEN Channels and bolts).
^③ Check flange thickness of the rail.

Load diagram KLP - 60

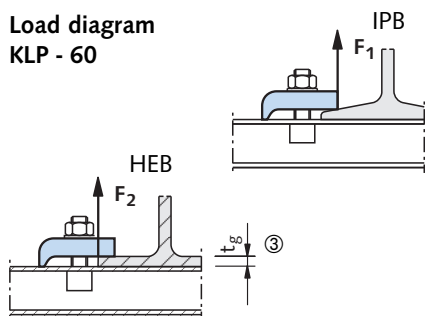

Assembly diagram KLP - 60

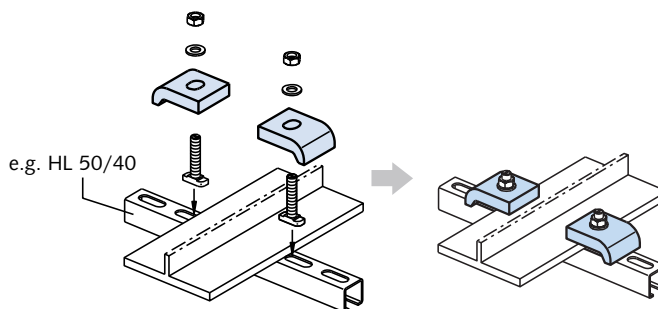

Assembly example:

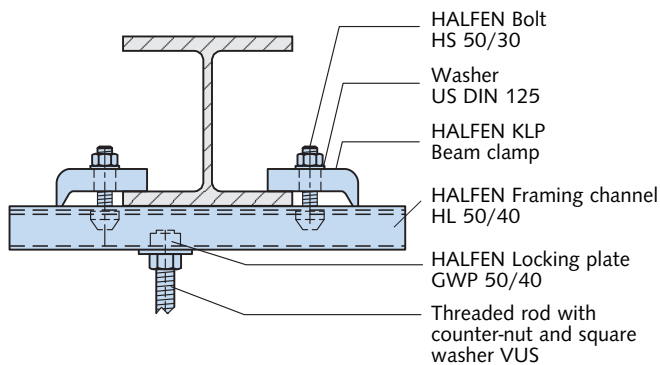

Order example:

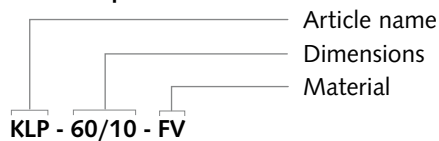

HALFEN FLEXIBLE FRAMING CONSTRUCTIONS

Nuts, Washers

MU

Hexagonal nuts
DIN EN ISO 4032/
DIN 934

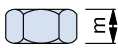

GV galvanized grade 8 thread	A4 stainless steel thread	S/m DIN [mm]	S/m ISO [mm]	e [mm]
M6	M6	10/5	10/6	11.5
M8	M8	13/6.5	13/7.5	15.0
M10	M10	17/8	16/ 9.5	19.6
M12	M12	19/10	18/12	21.9
M16	M16	24/13	24/15.5	27.7
M20	M20	30/16	30/19	34.6
M24	M24	36/19	36/22	41.5
FV hot-dip galvanized thread	A2 stainless steel thread	S/m DIN [mm]	S/m EN [mm]	e [mm]
M6, M8	M8	13/6.5	13/7.5	15.0
M10	M10	17/08	16/ 9.5	19.6
M12	M12	19/10	18/12	21.9
M16	M16	24/13	24/15.5	27.7

VUS

Square washers

VUS 40/25
for profile
40/25;
HZA
41/22

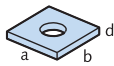

VUS 49/30
for profile
54/33,
49/30

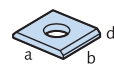

VUS 52/34
for profile
52/34,
50/30

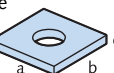

VUS 72/49
for profile
72/48,
72/49

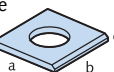

VUS 41/41
for all
41
profiles

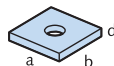

FV hot-dip galvanized for bolt	A4 stainless steel for bolts	a × b × d [mm]
M10	M10	40 × 40 × 5
M12	M12	40 × 40 × 5
M16	M16	40 × 40 × 5
M10	M10	37 × 37 × 5
M12	M12	37 × 37 × 5
M16	M16	37 × 37 × 5
M20	M20	37 × 37 × 5
M16	M16	50 × 50 × 6
M20	M20	50 × 50 × 6
M20	M20	54 × 54 × 6
M24	M24	54 × 54 × 6
M27	M27	54 × 54 × 6
M30	M30	54 × 54 × 6
M6	M6	40 × 40 × 6
M10	M10	40 × 40 × 6
M12	M12	40 × 40 × 6

Ordering example: VUS 52/34 - FV - M20

Application VUS:

For shimming non-flush installation of HALFEN Anchor channels or for stand-off installations.

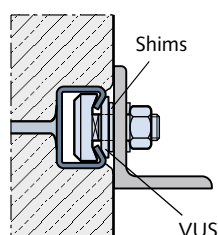

US

Washers
DIN EN
ISO 7093-1/
ISO 7094,
DIN 9021/
DIN 440

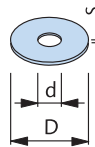

DIN	GV galvanized for bolt	A4 stainless steel for bolt	D [mm]	d [mm]	s [mm]
440	M6		22	6.6	2
9021	M8	M8	24	8.4	2
9021	M10	M10	30	10.5	2.5
440	M12		45	13.5	4
9021	M12	M12	37	13	3
9021	M16	M16	50	17	3
440	M20		72	22	6

Ordering example: US - M12 - GV - DIN 9021

US

Washers
DIN EN ISO
7089/
DIN 125

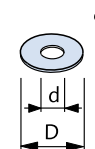

GV galvanized for bolt	A4 stainless steel for bolt	D [mm]	d [mm]	s [mm]
M6	M6	12	6.4	1.6
M8	M8	16	8.4	1.6
M10	M10	21	10.5	2
M12	M12	24	13	2.5
M16	M16	30	17	3
M20	M20	37	21	3
M24		44	25	4
		50	28	4
		56	31	4
FV hot-dip galvanized for bolt	A2 stainless steel for bolt	D [mm]	d [mm]	s [mm]
	M8	17	8.4	1.6
M10	M10	21	10.5	2
M12	M12	24	13	2.5
M16	M16	30	17	3

Ordering example: US - M12 - GV - DIN 125

SIC

Locking washer

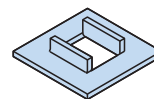

GV galvanized	A4 stainless steel	Suitable for HALFEN Bolts	
		type	dimensions
SIC - 50/30 - GV	SIC - 50/30 - A4	50/30	M16, M20
SIC - 40/22 - GV	SIC - 40/22 - A4	38/17 40/22	M16
SIC - 38/23 - GV		38/23	M16
SIC - 29/20 - GV		29/20	M12
SIC - 38/17 - GV	SIC - 38/17 - A4	38/17 40/22	M12, M10
SIC - 28/15 - GV	SIC - 28/15 - A4	28/15	M8, M10
SIC - 20/12 - GV	SIC - 20/12 - A4	20/12	M8

Ordering example: SIC - 38/17 - GV

Application SIC:

For securing HALFEN Bolts; prevents bolts turning when tightening nuts.

Assembly scheme:

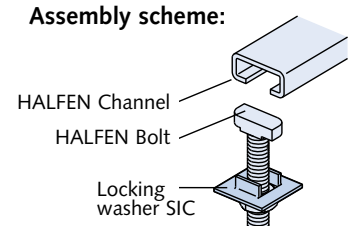

HALFEN FLEXIBLE FRAMING CONSTRUCTIONS

Threaded Rod, Hexagon Bolts, Coupler Sleeves, Ring nuts

GWS

Threaded rods
DIN 976-1

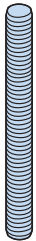

GV	A4	Length	F _{Rd}	perm.F
electroplated grade 4.6 thread	stainless steel thread	[mm]	① [kN]	[kN]
M6	M6	1000	3.1	2.2
M8	M8	1000	5.6	4.0
M10	M10	1000	9.0	6.4
M12	M12	1000	13.0	9.3
M16	M16	1000	24.2	17.3
M20	M20	1000	37.8	27.0
M24		1000	54.3	38.8

Ordering example: GWS - M12 × 1000 - GV

VBM

Coupler sleeves, round

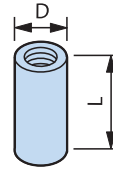

GV	A4	D	L	F _{Rd}	perm.F
electroplated thread	stainless steel thread	[mm]	[mm]	① [kN]	[kN]
M6	M6	10/10	15	3.1	2.2
M8	M8	12/14	20	5.6	4.0
M10	M10	13/16	25	9.0	6.4
M12	M12	16/20	30	13.0	9.3
M16	M16	21/25	40	24.2	17.3
M20	M20	26/32	50	37.8	27.0

Ordering example: VBM - A4 - M16

HSK

Hexagonal head bolts
DIN EN ISO 4017/
DIN 933
(without nut)

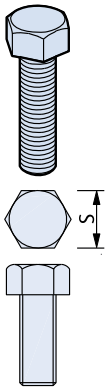

Hex bolts are used in combination with HALFEN Threaded plates

GV 8.8	A4	S	S
galvanized grade 8.8 dimensions	stainless steel dimensions	DIN [mm]	EN ISO [mm]
M6 × 12		10	10
M6 × 25			
M8 × 25	M8 × 25	13	13
M8 × 40			
M10 × 20			
M10 × 30	M10 × 30		
M10 × 45	M10 × 45	17	16
M10 × 60			
M10 × 70			
M12 × 22			
M12 × 25	M12 × 25		
M12 × 30	M12 × 30		
M12 × 40	M12 × 40	19	18
M12 × 50			
M12 × 60	M12 × 60		
M12 × 80	M12 × 80		
M12 × 90			
M16 × 40	M16 × 40		
M16 × 60	M16 × 60	24	24
M16 × 90	M16 × 90		

SKM

Hexagonal coupler sleeves with view holes

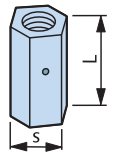

FV	A4	S	L	F _{Rd}	perm.F
hot-dip galvanized thread	stainless steel thread	[mm]	[mm]	① [kN]	[kN]
M10	M10	13	40	9.0	6.4
M12	M12	17	40	13.0	9.3
M16	M16	22	50	24.2	17.3

Ordering example: SKM - FV - M12

SPH

Turnbuckles with right- and left-hand thread

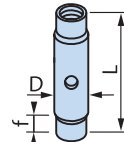

f = min. screw depth
M12 ≧ 10 mm
M16 ≧ 13 mm

A4	A4	D	D
stainless steel thread M12 × length L [mm]	stainless steel thread M16 × length L [mm]	for M12 [mm]	for M16 [mm]
M12 × 60	M16 × 60	16	22
M12 × 75	M16 × 75	16	22
M12 × 95	M16 × 95	16	22
M12 × 115	M16 × 115	16	22
M12 × 135	M16 × 135	16	22
perm. F = 5 kN F _{Rd} = 7 kN	perm. F = 10 kN F _{Rd} = 14 kN		

Ordering example: SPH - A4 - M12 × 75

HJV

Adjustment coupler

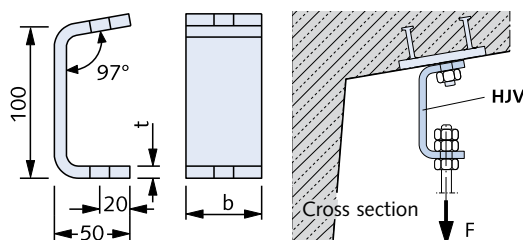
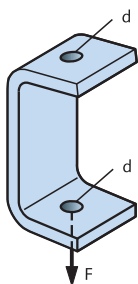

FV	A4	t	b	d	max F _{Ed}	per.F
hot-dip galvanized type	stainless steel type	[mm]	[mm]	[mm]	[kN]	[kN]
1	1	6	40	13	2.1	1.5
2	2	8	50	17	4.6	3.3
3	3	10	50	17	7.0	5

RM

Ring nut
DIN 582
edition 2003-8

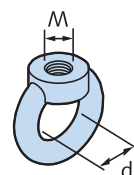

GV	d	F _{Rd}	perm. F
C15E, electroplated thread	[mm]	① [kN]	[kN]
M8	20	2.0	1.4
M10	25	3.2	2.3
M12	30	4.8	3.4
M16	35	9.8	7.0
M20	40	16.8	12.0

Ordering example: RM - GV - M12

- ① Recommended design value of the load capacity with a centric tensile stress
- ② Recommended design value of the load

HALFEN FLEXIBLE FRAMING CONSTRUCTIONS

Adjustable Framework Construction - Accessories

Vibration absorber SDM

Material: Elastomer - Industrial quality (EPDM) 45 ± 5 (Shore hardness)

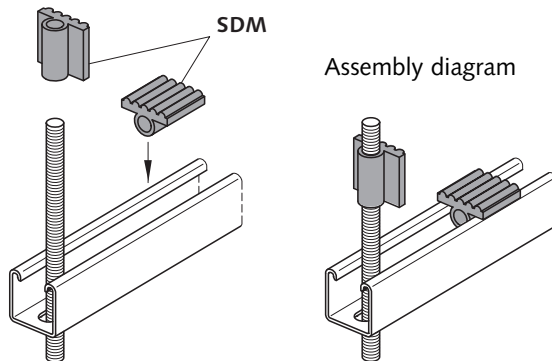
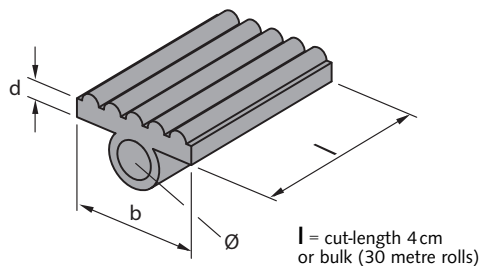

Dimensions					
Article name	Length	Order no.	Suitable for	Suitable for	Suitable for
width/thickness		0319.000-	channel slot width [mm]	channel type	threaded rod
SDM 41/8 -	bulk ①	00001	22	50/40, 41/41 - 41/83	Ø M12
SDM 41/8 -	4 cm - item	00002			
SDM 36/6 -	bulk ①	00003	18	36/36	Ø M10
SDM 36/6 -	4 cm - item	00004			
SDM 28/6 -	bulk ①	00005	12 - 14	28/28, 26/26, 28/15	Ø M8
SDM 28/6 -	4 cm - item	00006			

① Please indicate length [m] when ordering. Bulk for this article is 30 m.

Example; vibration absorber placement SDM

Support elements for ductwork suspensions

Fixing point
to concrete constructions:
HALFEN Channel

Threaded rod
zinc galvanized, see page 37

Vibration absorber
Material: EPDM

HALFEN Slotted channel
hot-dip galvanized, sendzimir-galvanized
channel to accommodate loads in
accordance with table

Washers, nuts
zinc galvanized, see page 36

HPE Channel end caps,
see page 39

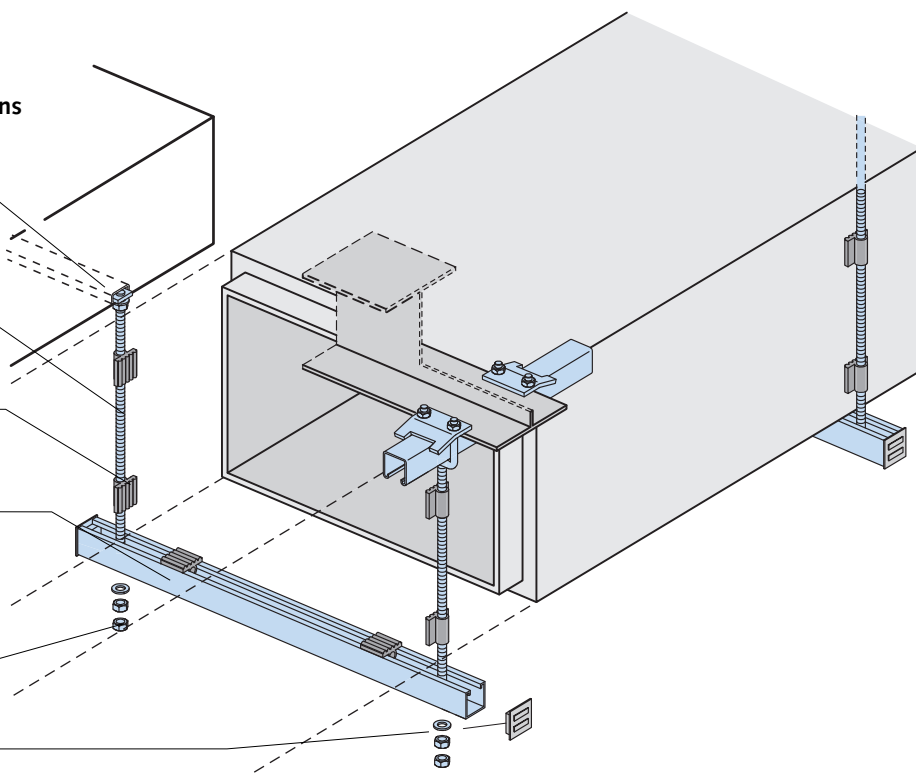

HALFEN FRAMING CHANNELS ACCESSORIES

Channel End Caps, Channel Cover Strip

HPE Channel end cap

Channel end caps (in plastic)



Type **HPE 63/63**
Colour: Blue

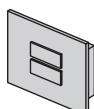

Type **HPE**
Colour: Black

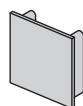

Type **HPE 41/41**
Type **HPE 41/22**
Colour: Black

Order numbers		
Article name	Order no. 0318.	Suitable for channel
HPE 63/63	000-00010	63/63
HPE 52/34	000-00001	52/34
HPE 50/40	000-00002	50/40
HPE 41/41	000-00003	41/41
HPE 41/22	000-00004	41/22
HPE 36/36	000-00005	36/36
HPE 28/28	000-00006	28/28
HPE 28/15	000-00011	28/15
HPE 26/26	000-00007	26/26
HPE 26/18	000-00009	26/18

Assembly diagram:

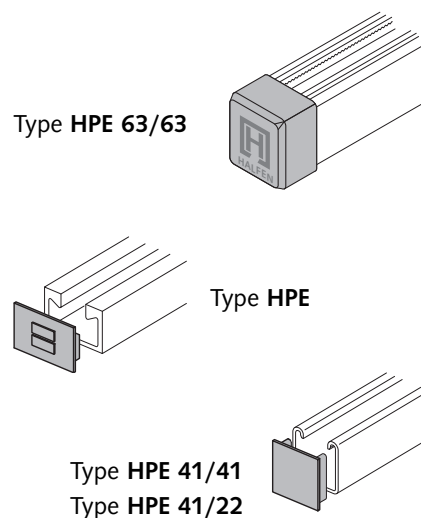

PA Channel cover

The channel cover strip provides a clean finish and protects the channel against dirt and damage.

Type overview			
Type:	PA 41	PA 22	PA 18 H
	Suitable for channel: 50/40, 50/30, 486, for all 41 channels	Suitable for channel: 52/34	Suitable for channel: 36/36, 38/17
Material: Hard PVC (KS)	 white	 medium grey	 medium grey
Material: Steel sendzimir- galvanized (SV)	 white		

Assembly diagram

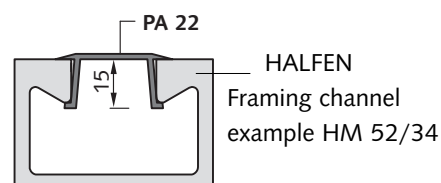

Order no.		
Type	Length [mm]	Order no. 0321.000-
PA -41- KS	- 3000	00002
PA -41- SV	- 3000	00001
PA -22- KS	- 3000	00003
PA -8H- KS	- 3000	00004

HALFEN FLEXIBLE FRAMING CONSTRUCTIONS

Pipe Clamps, Pipe Supports

HALFEN Pipe clamps and pipe supports

Adjustable pipe clamps

The HALFEN Pipe clamp range is an optimised and flexible solution used in combination with standard

HALFEN Cast-in channels and framing systems. HALFEN supplies pipe clamps of various types for pipe diameters of 15 to 530 mm.

The flexibility of the pipe fixings guarantees adjustability in all directions.

Assembly example

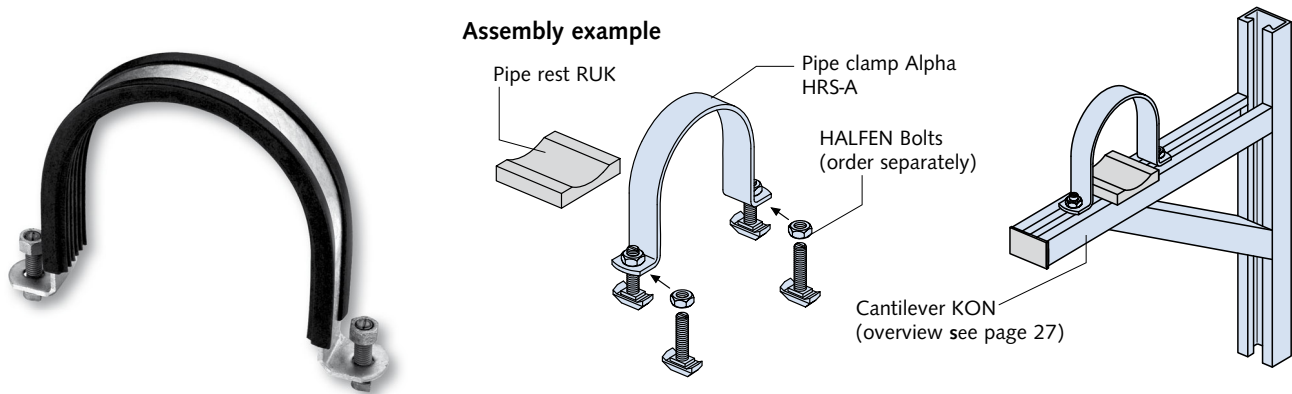

Type selection

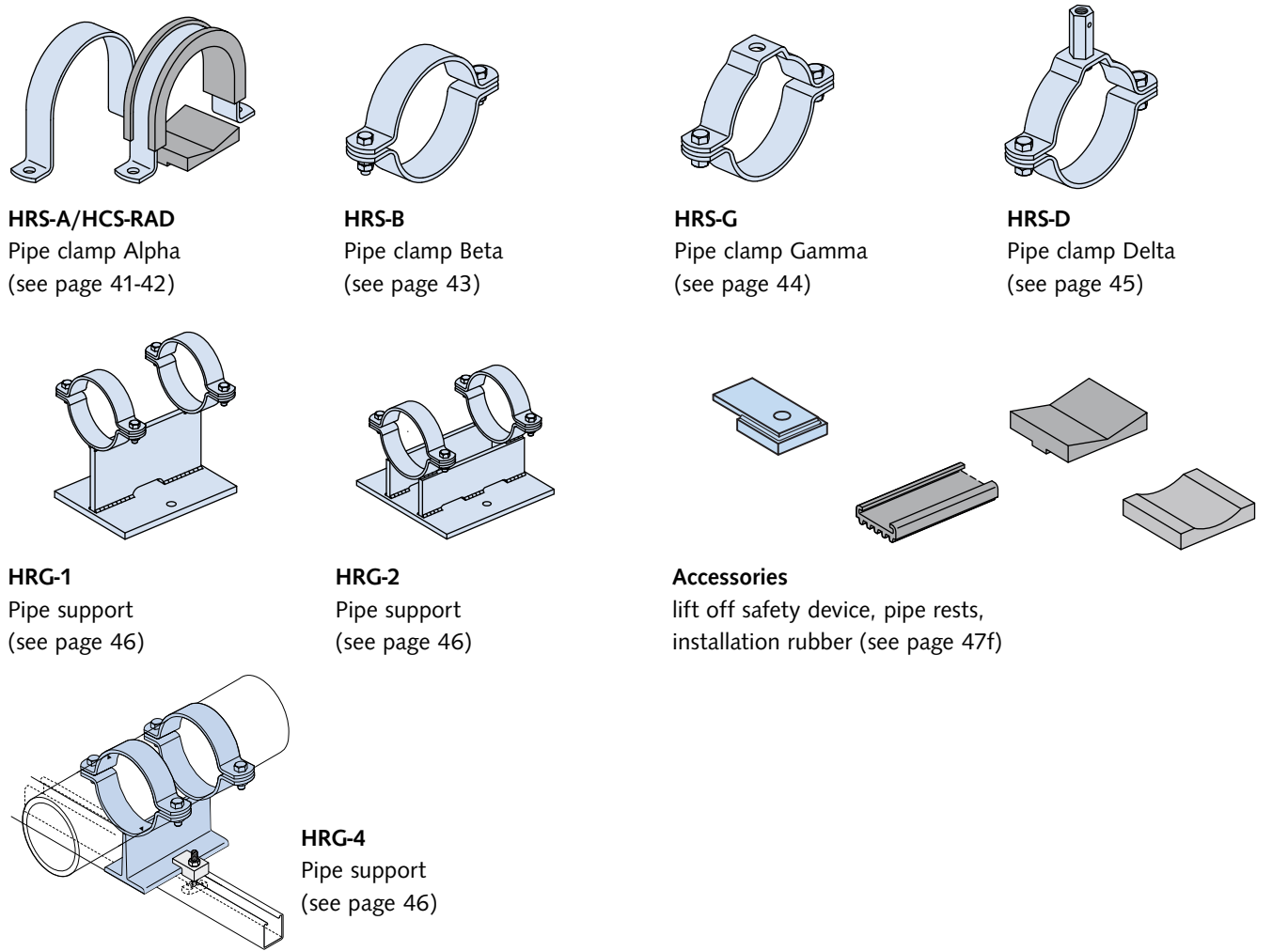

HALFEN FLEXIBLE FRAMING CONSTRUCTIONS

Pipe Clamps, Pipe Supports

Pipe clamp - Type Alpha

HRS-A
Pipe clamp Alpha

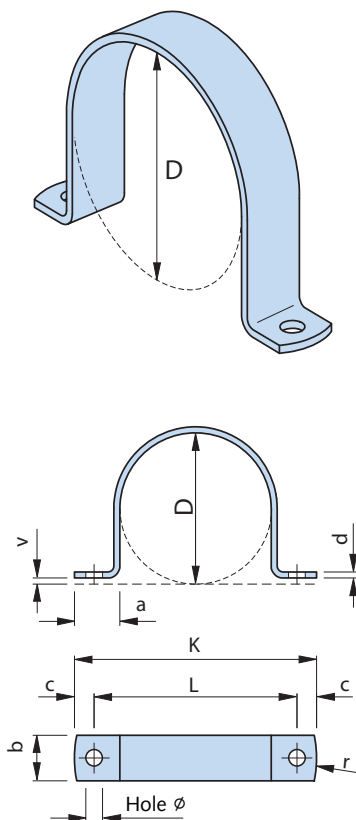

Pipe clamp HRS-A													
Type FV hot-dip galvanized		Type A4 stainless steel		Clamp-range min-max [mm]	hole Ø [mm]	Dimensions						Pre-tension value [mm]	
Ø D [mm]	Order no. 0311.010-	Ø D [mm]	Order no. 0311.010-			b/d [mm]	L [mm]	K [mm]	a [mm]	c [mm]	r [mm]		v [mm]
17	00048	17	00001	16 - 19	11 for M10	25/2.5	51	77	30	13	16	2.75	
21.5	00049	21.5	00002	20.5 - 23.5			55.5	81.5					
27	00050	27	00003	26 - 29			61	87					
33.5	00051	33.5	00004	32.5 - 35.5			67.5	93.5					
42.5	00052	42.5	00005	41.5 - 44.5			76.5	102.5					
48.5	00053	48.5	00006	47.5 - 50.5			82.5	108.5					
50	00054	50	00007	49 - 52			84	110					
56	00055	56	00008	55 - 58			90	116					
60	00056	60	00009	59 - 62			94	120					
64	00057	64	00010	63 - 66			98	124					
77	00058	77	00011	76 - 79	111	137	30	13	19	4			
80	00059	80	00012	79 - 82	114	140							
84	00060	84	00013	83 - 86	118	144							
89	00061	89	00014	88 - 91	123	149							
96	00062	96	00015	95 - 98	130	156							
100	00063	100	00016	98 - 102	134	160							
105	00064	105	00017	103 - 107	139	165							
110	00065	110	00018	108 - 112	144	170							
116	00066	116	00019	114 - 118	150	176							
125	00067	125	00020	123 - 127	159	185							
131	00068	131	00021	129 - 133	165	191	13 for M12	16	24	4			
137	00069	137	00022	135 - 139	171	197							
141	00070	141	00023	139 - 143	175	201							
150	00071	150	00024	148 - 152	184	210							
157	00072	157	00025	155 - 159	191	217							
160	00073	160	00026	158 - 162	208	240							
168	00074	168	00027	166 - 170	216	248							
176	00075	176	00028	174 - 178	224	256							
185	00076	185	00029	183 - 187	233	265							
200	00077	200	00030	198 - 202	248	280							
212	00078	212	00031	210 - 214	260	292	17 for M16	25	36	5			
218	00079	218	00032	216 - 220	266	298							
225	00080	225	00033	223 - 227	273	305							
235	00081	235	00034	233 - 237	283	315							
267	00083	267	00035	265 - 269	317	367							
273	00084	273	00036	271 - 275	323	373							
285	00085	285	00037	283 - 287	335	385							
326	00086	326	00038	324 - 328	376	426							
340	00087	340	00039	338 - 342	390	440							
355	00088	355	00040	353 - 357	405	455							
400	00089	400	00041	398 - 402	450	500	17 for M16	25	36	5			
406	00090	406	00042	404 - 408	456	506							
420	00091	420	00043	418 - 422	470	520							
429	00092	429	00044	427 - 431	479	529							
508	00093	508	00045	506 - 510	558	608							
525	00094	525	00046	523 - 527	575	625							
532	00095	532	00047	530 - 534	582	635							

HALFEN FLEXIBLE FRAMING CONSTRUCTIONS

Pipe Clamps, Pipe Supports

Pipe clamp – assembly set

HCS-RAD

Pipe clamp assembly set with DGM Installation rubber and pipe rest RUV and RUK

Set includes:

- 1 × Pipe clamp Alpha
 - 1 × installation rubber DGM (bulk length)
 - 1 × Pipe rest RUV or RUK
- Order matching T-head bolts separately!

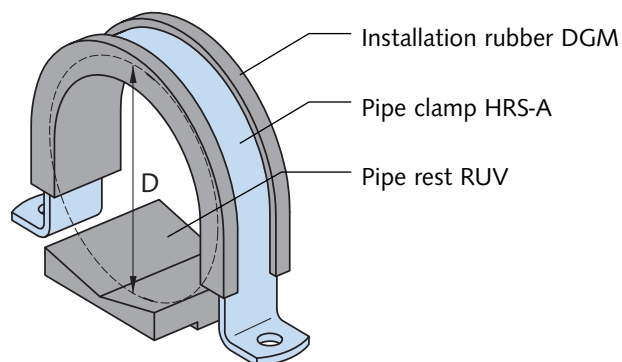

Note:

When using DGM Installation rubber always use a RUK or RUV pipe rest.

For pipe clamps with installation rubber the effective diameter is $D_{\text{eff}} = \text{diameter } D - 16 \text{ mm}$.

Pipe clamps are suitable for pipe-diameters as listed in the table (see clamp-range value).

Pipe clamp – assembly set HCS-RAD

Material FV hot-dip galvanized		Material A4 stainless steel		Clamp-range min-max [mm]	Dimensions DGM Length [mm]
Ø D ① [mm]	Order no. 0303.010-	Ø D ① [mm]	Order no. 0303.010-		
Type DGM 25/8					
33.5	00042	33,5	00001	16.5 - 21.5	1 × 75
42.5	00043	42,5	00002	25.5 - 30.5	1 × 75
48.5	00044	48,5	00003	31.5 - 36.5	1 × 120
50	00045	50	00004	33 - 38	1 × 120
56	00046	56	00005	39 - 44	1 × 120
60	00047	60	00006	43 - 48	1 × 150
64	00048	64	00007	47 - 52	1 × 150
77	00049	77	00008	60 - 65	1 × 180
80	00050	80	00009	63 - 68	1 × 180
84	00051	84	00010	67 - 72	1 × 180
89	00052	89	00011	72 - 77	1 × 210
96	00053	96	00012	79 - 84	1 × 210
Type DGM 30/8					
100	00054	100	00013	83 - 88	1 × 250
105	00055	105	00014	88 - 93	1 × 250
110	00056	110	00015	93 - 98	1 × 250
116	00057	116	00016	99 - 104	1 × 250
125	00058	125	00017	108 - 113	1 × 305
131	00059	131	00018	114 - 119	1 × 305
137	00060	137	00019	120 - 125	1 × 305
141	00061	141	00020	124 - 129	1 × 305
150	00062	150	00021	133 - 138	1 × 355
157	00063	157	00022	140 - 145	1 × 355
Type DGM 40/8					
160	00064	160	00023	143 - 148	1 × 395
168	00065	168	00024	151 - 156	1 × 395
176	00066	176	00025	159 - 164	1 × 395
185	00067	185	00026	168 - 173	1 × 450
200	00068	200	00027	183 - 188	1 × 450
212	00069	212	00028	195 - 200	1 × 500
218	00070	218	00029	201 - 206	1 × 500
225	00071	225	00030	208 - 213	1 × 560
235	00072	235	00031	218 - 223	1 × 560
Type DGM 50/8					
267	00073	267	00032	250 - 255	1 × 650
273	00074	273	00033	256 - 261	1 × 650
285	00075	285	00034	268 - 273	1 × 700
326	00076	326	00035	309 - 314	1 × 800
340	00077	340	00036	323 - 328	1 × 800
355	00078	355	00037	338 - 343	1 × 860
400	00079	400	00038	383 - 388	1 × 1015
406	00080	406	00039	389 - 394	1 × 1015
420	00081	420	00040	403 - 408	1 × 1015
429	00082	429	00041	412 - 417	1 × 1015
508		508		491 - 496	1 × 1295
525		525		508 - 513	1 × 1295
532		532		515 - 520	1 × 1295

① Ø D = Nominal diameter of pipe clamp without installation rubber

HALFEN FLEXIBLE FRAMING CONSTRUCTIONS

Pipe Clamps, Pipe Supports

Pipe clamp - Type Beta

HRS-B

Pipe clamp Beta

Set includes:

- 1 × Pipe clamp HRS-B
- 2 × Hex. head bolts
- 2 × Nuts

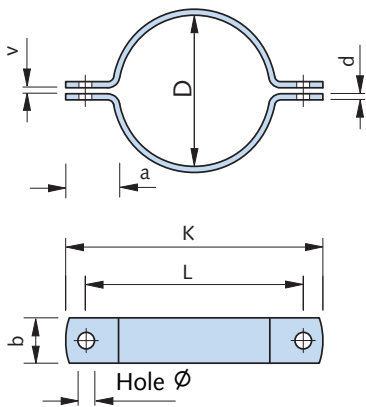
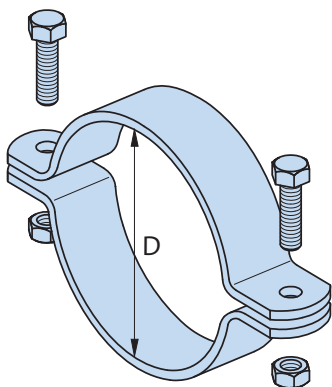

Accessory:

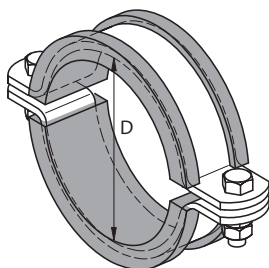

DGM Installation rubber
(see page 49)

Pipe clamp HRS-B

Material FV hot-dip galvanized		Material A4 stainless steel		Clamp-range min - max [mm]	Hole Ø [mm]	Dimensions					Pre- tension value [mm]	allow. load capacity [kN]
Ø D [mm]	Order no. 0311.030-	Ø D [mm]	Order no. 0311.030-			b/d [mm]	L [mm]	K [mm]	a [mm]	v [mm]		
21.5	00049	21.5	00002	20.5 - 23.5	6,5 for M6	25/2.5	49.5	71.5	25	2.75	1.9	
27	00050	27	00003	26 - 29			55	77				
33.5	00051	33.5	00004	32.5 - 35.5			61.5	83.5				
42.5	00052	42.5	00005	41.5 - 44.5			70.5	92.5				
48.5	00053	48.5	00006	47.5 - 50.5			76.5	98.5				
50	00054	50	00007	49 - 52			78	100				
56	00055	56	00008	55 - 58			84	106				
60	00056	60	00009	59 - 62			88	110				
64	00057	64	00010	63 - 66			92	114				
77	00058	77	00011	76 - 79			105	127				
80	00059	80	00012	79 - 82	8,5 for M8	30/4	108	130	35	4	4.1	
84	00060	84	00013	83 - 86			112	134				
89	00061	89	00014	88 - 91			118	140				
96	00062	96	00015	95 - 98			125	147				
100	00063	100	00016	98 - 102			144	170				
105	00064	105	00017	103 - 107			149	175				
110	00065	110	00018	108 - 112			154	180				
116	00066	116	00019	114 - 118			160	186				
125	00067	125	00020	123 - 127			169	195				
131	00068	131	00021	129 - 133			175	201				
137	00069	137	00022	135 - 139	181	207						
141	00070	141	00023	139 - 143	185	211						
150	00071	150	00024	148 - 152	194	220						
157	00072	157	00025	155 - 159	201	227						
160	00073	160	00026	158 - 162	13 for M12	40/4	208	240	40	4	4.9	
168	00074	168	00027	166 - 170			216	248				
176	00075	176	00028	174 - 178			224	256				
185	00076	185	00029	183 - 187			233	265				
200	00077	200	00030	198 - 202			248	280				
212	00078	212	00031	210 - 214			260	292				
218	00079	218	00032	216 - 220			266	298				
225	00080	225	00033	223 - 227			273	305				
235	00081	235	00034	233 - 237			283	315				
267	00082	267	00035	265 - 269			317	367				
273	00083	273	00036	271 - 275	17 for M16	50/5	323	373	50	5	7.8	
285	00084	285	00037	283 - 287			335	385				
326	00085	326	00038	324 - 328			376	426				
340	00086	340	00039	338 - 342			390	440				
355	00087	355	00040	353 - 357			415	465				
400	00088	400	00041	398 - 402			460	510				
406	00089	406	00042	404 - 408			466	516				
420	00090	420	00043	418 - 422			480	530				
429	00091	429	00044	427 - 431			489	539				
508	00092	508	00045	506 - 510			568	618				
525	00093	525	00046	523 - 527	585	635						
532	00094	532	00047	530 - 534	592	642						

HALFEN FLEXIBLE FRAMING CONSTRUCTIONS

Pipe Clamps, Pipe Supports

Pipe clamp - Type Gamma

HRS-G

Pipe clamp Gamma

Set includes:

- 1 × Pipe clamp Gamma
- 2 × Hex. head bolts
- 2 × Nuts

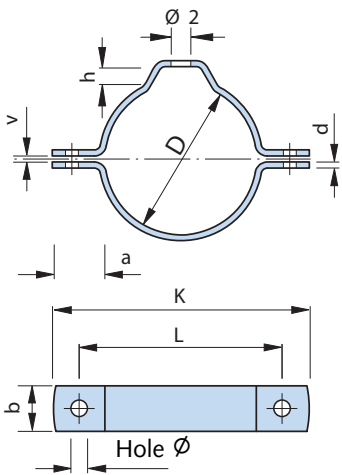
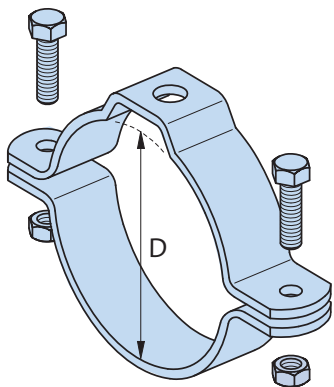

Pipe clamp HRS-G

Material FV hot-dip galvanized		Material A4 stainless steel		Clamp-range min-max [mm]	Hole Ø [mm]	Dimensions						Pre-tension value [mm]	allow. load capacity [kN]		
Ø D [mm]	Order no. 0311.060-	Ø D [mm]	Order no. 0311.060-			b/d [mm]	L [mm]	K [mm]	a [mm]	h [mm]	Ø 2 [mm]			v [mm]	
64	00030	64	00001	63 - 66	8.5 for M8	25/2.5	92	114							
77	00031	77	00002	76 - 79			105	127							
80	00032	80	00003	79 - 82			108	130	25	9	11	2.75	1.9		
89	00033	89	00004	88 - 91			118	140							
96	00034	96	00005	95 - 98			125	147							
100	00035	100	00006	98 - 102	11 for M10	30/4	144	170							
105	00036	105	00007	103 - 107			149	175							
110	00037	110	00008	108 - 112			154	180							
116	00038	116	00009	114 - 118			160	186							
125	00039	125	00010	123 - 127			169	195	35	11	13	4	4.1		
131	00040	131	00011	129 - 133			175	201							
137	00041	137	00012	135 - 139			181	207							
141	00042	141	00013	139 - 143			185	211							
150	00043	150	00014	148 - 152			194	220							
157	00044	157	00015	155 - 159			201	227							
160	00045	160	00016	158 - 162	13 for M12	40/4	208	240							
168	00046	168	00017	166 - 170			216	248							
176	00047	176	00018	174 - 178			224	256							
185	00048	185	00019	183 - 187			233	265							
200	00049	200	00020	198 - 202			248	280	40	14	17	4	4.9		
212	00050	212	00021	210 - 214			260	292							
218	00051	218	00022	216 - 220			266	298							
225	00052	225	00023	223 - 227			273	305							
235	00053	235	00024	233 - 237			283	315							
267	00054	267	00025	265 - 269			17 for M16	50/5	317	367					
273	00055	273	00026	271 - 275	323	373									
285	00056	285	00027	283 - 287	335	385			50	18	17	5	7.8		
326	00057	326	00028	324 - 328	376	426									
340	00058	340	00029	338 - 342	390	440									

Accessory:

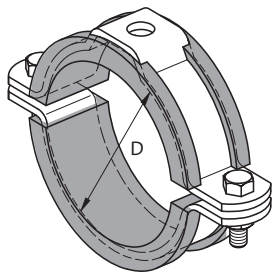

DGM Installation rubber
(see page 49)

HALFEN FLEXIBLE FRAMING CONSTRUCTIONS

Pipe Clamps, Pipe Supports

Pipe clamp - Type Delta

HRS-D

Pipe clamps Delta

Set includes:

- 1 × Pipe clamp with hexagonal rod coupler, pivoted and permanently fixed to pipe clamp
- 2 × Hex. head bolts
- 2 × Nuts

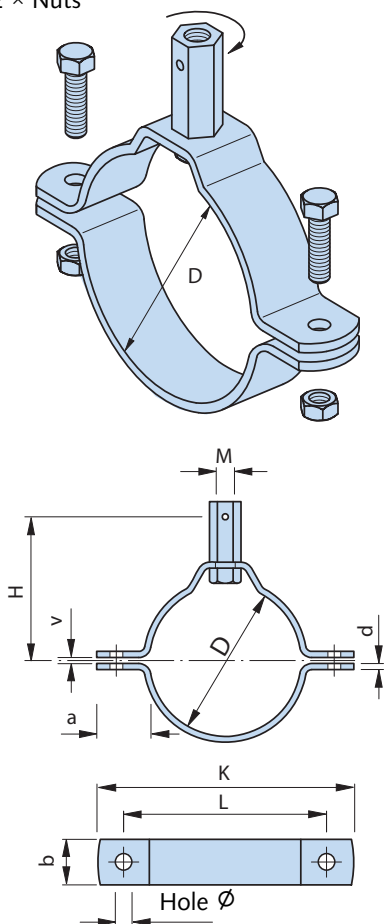

Accessory:

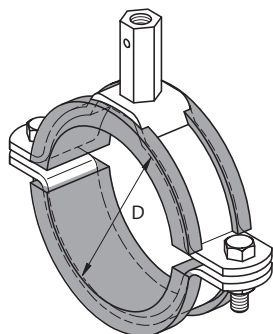

DGM Installation rubber (see page 49)

Pipe clamp HRS-D

Material FV hot-dip galvanized		Material stainless steel A4		Clamp range min-max [mm]	Hole Ø [mm]	Dimensions					M [mm]	Pre-tension value [mm]	allow. load capacity [kN]
Ø D [mm]	Order no. 0311.050-	Ø D [mm]	Order no. 0311.050-			b/d [mm]	L [mm]	K [mm]	a [mm]	H [mm]			
64	00030	64	00001	63 - 66	8 for M8	25/2.5	92	114		78	M10 x40 ①	2.75	1.9
77	00031	77	00002	76 - 79			105	127		85			
80	00032	80	00003	79 - 82			108	130	25	86			
89	00033	89	00004	88 - 91			118	140		91			
96	00034	96	00005	95 - 98			125	147		94			
100	00035	100	00006	98 - 102	11 for M10	30/4	144	170		98	M12 x40 ①	4	4.1
105	00036	105	00007	103 - 107			149	175		100			
110	00037	110	00008	108 - 112			154	180		103			
116	00038	116	00009	114 - 118			160	186		106			
125	00039	125	00010	123 - 127			169	195	35	110			
131	00040	131	00011	129 - 133			175	201		113			
137	00041	137	00012	135 - 139			181	207		116			
141	00042	141	00013	139 - 143			185	211		118			
150	00043	150	00014	148 - 152			194	220		123			
157	00044	157	00015	155 - 159			201	227		126			
160	00045	160	00016	158 - 162	13 for M12	40/4	208	240		139	M16 x50 ①	4	4.9
168	00046	168	00017	166 - 170			216	248		143			
176	00047	176	00018	174 - 178			224	256		147			
185	00048	185	00019	183 - 187			233	265		151			
200	00049	200	00020	198 - 202			248	280	40	159			
212	00050	212	00021	210 - 214			260	292		165			
218	00051	218	00022	216 - 220			266	298		168			
225	00052	225	00023	223 - 227	273	305		171					
235	00053	235	00024	233 - 237	283	315		176					
267	00054	267	00025	265 - 269	17 for M16	50/5	317	367		197	M16 x50 ①	5	7.8
273	00055	273	00026	271 - 275			323	373		200			
285	00056	285	00027	283 - 287			335	385	50	206			
326	00057	326	00028	324 - 328			376	426		227			
340	00058	340	00029	338 - 342			390	440		234			

① with monitor hole

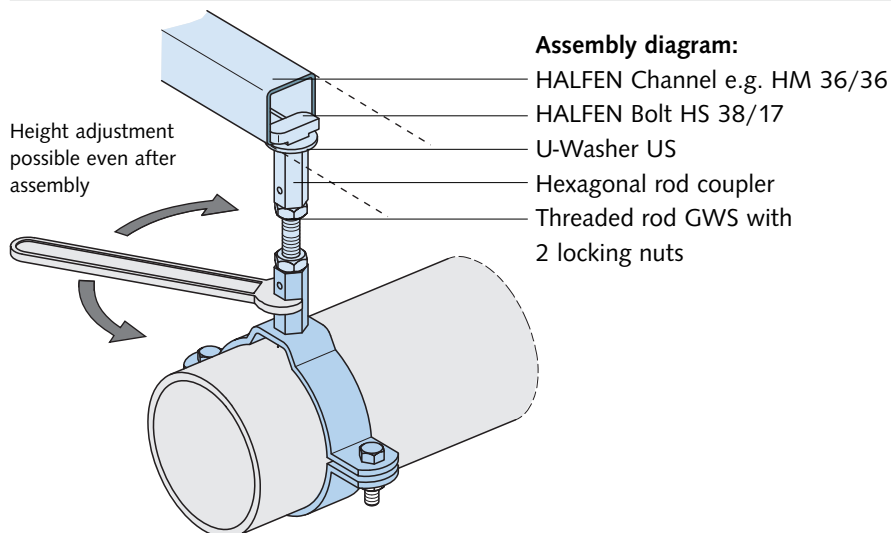

Assembly diagram:

- HALFEN Channel e.g. HM 36/36
- HALFEN Bolt HS 38/17
- U-Washer US
- Hexagonal rod coupler
- Threaded rod GWS with 2 locking nuts

Height adjustment possible even after assembly

HALFEN FLEXIBLE FRAMING CONSTRUCTIONS

Pipe Clamps, Pipe Supports

HRG Pipe support

HRG-1

for pipe diameters
D = 21.5 up to 185 mm

Pipe clamp type Beta

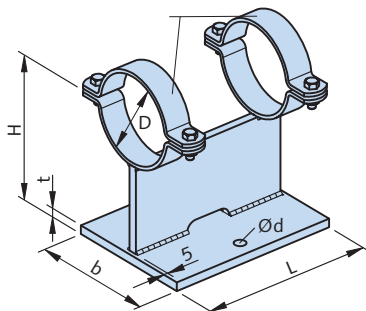

HRG-2

for pipe diameters
D = 176 up to 532 mm

Pipe clamp type Beta

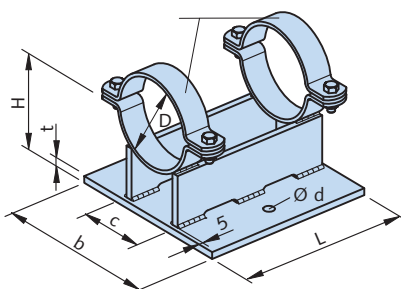

HRG-4 sliding support

Clamps acc. to DIN 3567, shape A
for nominal pipe diameters
DN = 15 up to DN 200 mm

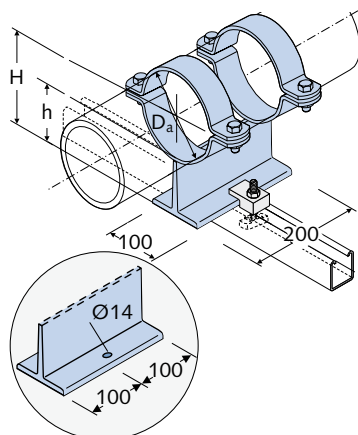

Pipe support HRG-1

HRG-1 for pipe- Ø D	Material: FV hot-dip galvanized Order no. 0291.-009-	Material: A4 stainless steel Order no. 0291.009-	Dimensions [mm]				
			H	L	b	Ø d	t
21,5 - 60	00004 ①	00001 ①	100	130	80	11	5
63 - 84			125	150	100	11	8
89 - 131			150	180	100	11	8
137 - 141			175	200	120	11	10
150 - 185			200	200	150	13	10

① When ordering please state the required pipe clamp diameter-Ø [mm].
Available diameters of pipe clamps see HRS-B, see page 43.
Note: Consider using a larger diameter clamp when using a DGM Installation rubber.

Pipe support HRG-2

HRG-2 for pipe- Ø D	Material: FV hot-dip galvanized Order no. 0291.-009-	Material: A4 stainless steel Order no. 0291.009-	Dimensions [mm]					
			H	L	b	c	Ø d	t
176 - 185	00005 ①	00002 ①	200	200	200	80	17	8
200 - 235			200	200	200	100	17	8
267 - 273			250	250	200	100	17	8
285			250	250	225	125	17	8
326			250	300	250	150	17	10
340 - 355			300	300	250	150	17	10
400 - 429			350	300	250	150	17	10
508 - 532			400	400	300	200	22	15

① When ordering please state the required pipe clamp diameter-Ø [mm].
Available diameters of pipe clamps see HRS-B, see page 43.
Note: Consider using a larger diameter clamp when using a DGM Installation rubber.

Pipe support HRG-4

For Pipe-Ø D _a	Material: FV hot-dip galvanized Order no.	Dimensions [mm]
		H
21.3	HRG 4 - 21 0291.040-00001	116
33.7	HRG 4 - 33 0291.040-00002	122
48.3	HRG 4 - 48 0291.040-00003	129
60.3	HRG 4 - 60 0291.040-00004	136
76.1	HRG 4 - 76 0291.040-00009	144
88.9	HRG 4 - 89 0291.040-00005	150
114.3	HRG 4 -116 0291.040-00006	166
139.7	HRG 4 -141 0291.040-00007	178
168.3	HRG 4 -168 0291.040-00008	192
219.1	HRG 4 -219 0291.040-00010	217.5

① When ordering please state the required pipe clamp diameter-Ø [mm].
Note: Consider using a larger diameter clamp when using a DGM Installation rubber.

HALFEN FLEXIBLE FRAMING CONSTRUCTIONS

Pipe Clamps, Pipe Supports – Accessories

Lift off safety device AHS

AHS

Lift off safety device for pipe T-supports

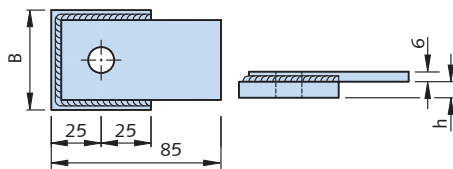
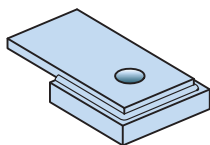

Other dimensions on request

Lift off safety device AHS

Type	Order no. 0324.000-	B [mm]	h [mm]	Ø d [mm]
AHS -1- FV	00001	50	8.0	13
AHS -2- FV	00002	50	10.0	13
AHS -3- FV	00003	50	12.0	13
AHS -4- FV	00004	70	20.0	17
AHS -1- A4	00005	50	8.0	13
AHS -2- A4	00006	50	10.0	13
AHS -3- A4	00007	50	12.0	13
AHS -4- A4	00008	70	20.0	17

Assembly diagram:

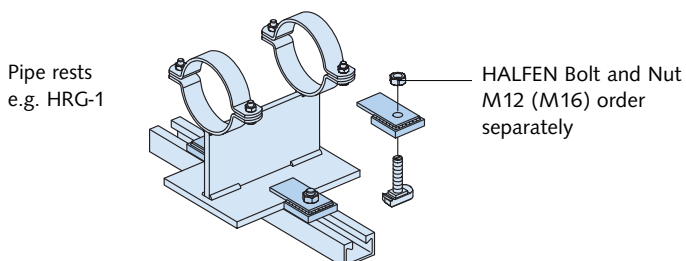

Lift off safety device AHS (used in pairs)

Pipe Rest

Pipe Rest RUK

Material: Polypropylene,
Temperature resistant
from -30 to +90°C,
Colour: Green

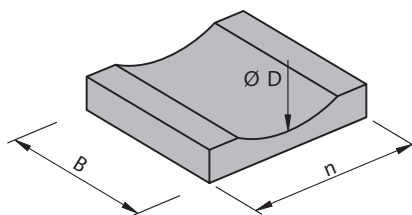

d2 = diameter of studs
Ø 10 – 30 mm (see table)

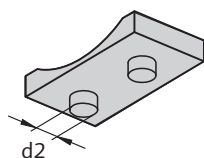

Channel slot width > d2

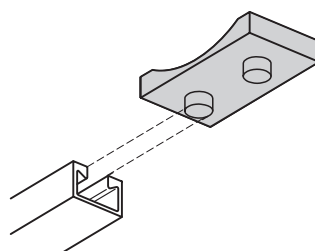

Channel slot width < d2

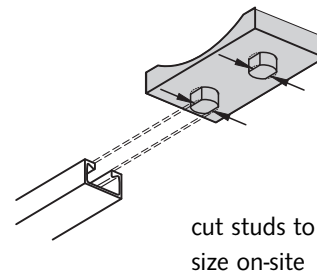

HALFEN FLEXIBLE FRAMING CONSTRUCTIONS

Pipe Clamps, Pipe Supports – Accessories

Assembly example

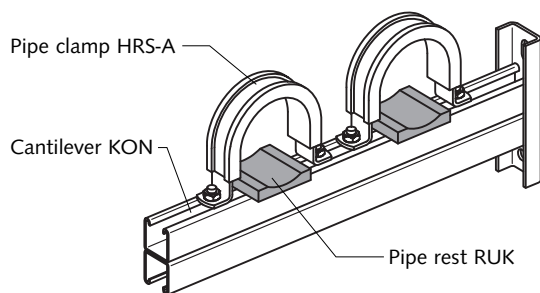

Pipe rest RUK					
Type	Order no. 0316.000-	for Ø D [mm]	Dimensions [mm]		
			n	B	d2
RUK - 57	00001	57	38	50	10
RUK - 60	00002	60			
RUK - 76	00003	76			
RUK - 88	00004	88			
RUK - 108	00005	108	75	70	15
RUK - 114	00006	114			
RUK - 133	00007	133			
RUK - 139	00008	139			
RUK - 159	00009	159	140	75	25
RUK - 168	00010	168			
RUK - 193	00011	193			
RUK - 216	00012	216			
RUK - 219	00013	219	220	75	30
RUK - 267	00014	267			
RUK - 273	00015	273			
RUK - 318	00016	318			
RUK - 323	00017	323	220	75	30
RUK - 355	00018	355			
RUK - 368	00019	368			
RUK - 406	00020	406			
RUK - 419	00021	419			
RUK - 508	00022	508			
RUK - 521	00023	521			

Pipe rests RUV-K, RUV-M, RUV-G

Pipe rest for various pipe diameters.
 Cost efficient alternative as one size RUV is suitable for various pipe sizes.
 The pipe rest is made of durable plastic (two-point-support).

Material: Polypropylene,
 Temperature resistant from -30 to +90° C,
 Colour: Black

Assembly example:

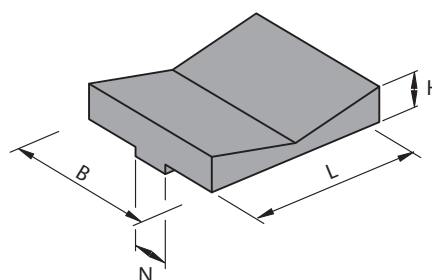
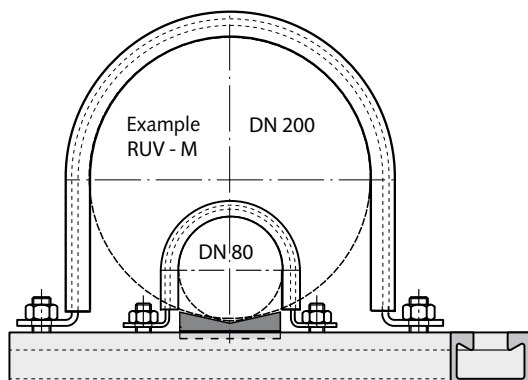

Pipe rest RUV						
Type	Order no. 0317.000-	for Ø D [mm]	Dimensions			
			L [mm]	B [mm]	N [mm]	H [mm]
RUV-K	0001	25 - 79	30	50	11	11
RUV-M	0002	80 - 269	80	70	17	15
RUV-G	0003	270 - 420	120	70	17	16

Type **RUV-K** for HALFEN Framing channels:
 min. 12 mm slot width, max. 52 mm channel width

Type **RUV-M** for HALFEN Framing channels:
 min. 18 mm slot width, max. 72 mm channel width

Type **RUV-G** for HALFEN Framing channels:
 min. 18 mm slot width, max. 72 mm channel width

HALFEN FLEXIBLE FRAMING CONSTRUCTIONS

Pipe Clamps, Pipe Supports – Accessories

Installation rubber DGM

Installation rubber DGM (bulk-ware)
for HALFEN Pipe clamps.

Material:
EPDM temperature resistant
from - 40°C to +110° C

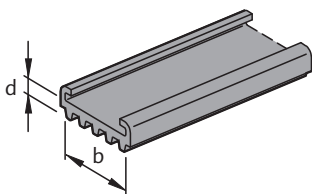

Note:

When using a DGM Installation rubber
always use a RUK or RUV pipe rest
(see pages 47-48).

Order numbers and lengths					
Pipe clamps-Ø D ①	Clamping range for DGM min. -max. [mm]	Length [mm]	DGM Installation rubber Type b/d [mm]		② Order no. 0320.000-
			Pipe clamp HRS-A	Pipe clamp HRS-B, -G, -D	
21.5		-			
27					
33.5	16.5 - 21.5	2 × 50			
42.5	25.5 - 30.5				
48.5	31.5 - 36.5				
50	33 - 38	2 × 70			
56	39 - 44				
60	43 - 48				
64	47 - 52	2 × 85			
77	60 - 65	2 × 110			
80	63 - 68				
84	67 - 72				
89	72 - 77	2 × 130			
96	79 - 84				
100	83 - 88				
105	88 - 93	2 × 155			
110	93 - 98				
116	99 - 104				
125	108 - 113	2 × 175			
131	114 - 119				
137	120 - 125	2 × 190			
141	124 - 129				
150	133 - 138	2 × 220			
157	140 - 145				
160	143 - 148	2 × 240			
168	151 - 156				
176	159 - 164	2 × 270			
185	168 - 173				
200	183 - 188	2 × 295			
212	195 - 200	2 × 310			
218	201 - 206				
225	208 - 213	2 × 345			
235	218 - 223				
267	250 - 255	2 × 405			
273	256 - 261				
285	268 - 273	2 × 435			
326	309 - 314	2 × 490			
340	323 - 328	2 × 530			
355	338 - 343	2 × 530			
400	383 - 388				
406	389 - 394	2 × 625			
420	403 - 408				
429	412 - 417				
508	491 - 496				
525	508 - 513	2 × 790			
532	515 - 520				

① Ø D = nominal diameter of the pipe clamp without installation rubber.
With insulated pipe clamp the effective diameter $D_{eff} = \text{Ø D} - 16 \text{ mm}$
② Please specify required length [m] when ordering.

HALFEN FLEXIBLE FRAMING CONSTRUCTIONS

Pipe Weights and Support Spacing

Threaded pipes, steel pipes			
Pipe outer diameter Ø ① [mm]	Pipe weight (empty) [kg/m]	Pipe weight (water filled) [kg/m]	Support spacing max. [m]
Threaded pipes according to DIN 10255 (medium duty)			
17.2	0.89	1.01	1.35
21.3	1.27	1.47	1.50
26.9	1.65	2.02	1.80
33.7	2.55	3.13	2.10
42.4	3.28	4.30	2.40
48.3	3.77	5.15	2.60
60.3	5.33	7.55	3.00
76.1	6.80	10.52	3.20
88.9	8.85	13.98	3.50
114.3	12.60	21.30	4.20
139.7	16.90	30.17	4.60
165.1	20.10	39.06	5.30
Steel pipe (heating pipes) according to DIN EN 10220			
17.2	0.69	0.83	1.40
21.3	0.96	1.2	1.60
26.9	1.41	1.8	1.85
33.7	2.01	2.65	2.15
44.5	2.70	3.91	2.50
48.3	2.95	4.41	2.60
51.0	3.12	4.77	2.70
57.0	3.90	5.96	2.80
60.3	4.14	6.47	3.00
63.5	4.36	6.97	3.00
76.1	5.28	9.16	3.50
82.5	6.31	10.86	3.65
88.9	6.81	12.15	3.80
101.6	8.76	15.76	4.00
108.0	9.33	17.31	4.10
114.3	9.90	18.9	4.20
127.0	12.20	23.32	4.35
133.0	12.80	25.07	4.40
139.7	13.50	27.12	4.50
152.4	16.40	32.54	4.75
159.0	17.10	34.76	4.80
168.3	18.10	36.93	4.90
177.8	21.30	43.4	5.00
193.7	25.00	51.26	5.20
219.1	31.00	64.73	5.50
267.0	40.60	91.40	5.90
273.0	41.60	95.40	5.90
298.5	51.10	117.60	6.20
318.0	57.40	129.50	6.40 ⑤
323.9	55.60	130.85	6.40 ⑤
406.4	85.90	204.40	7.10 ⑤
508.0	135.00	320.50	8.00 ⑤

Drainage pipes			
Pipe outer diameter Ø max. ① [mm]	Pipe weight (empty) [kg/m]	Pipe weight (water filled) [kg/m]	Support spacing max. [m]
Drainage pipe GA DIN 19 500 (previous version)			
60	5.300	7.505	0.60
80	7.100	11.283	0.80
112	10.300	18.791	1.15
137	13.700	26.763	1.35
162	17.300	35.437	1.60
212	32.700	64.100	2.00
Drainage pipe Cast iron (SML, ML)			
58	4.300	6.400	approx. 1.50 ②
78	5.900	9.900	
110	8.400	17.700	
135	11.800	24.500	
160	14.100	32.300	
210	23.100	54.600	
274	33.300	87.700	
326	43.200	120.800	
429	75.500	208.800	
532	104.300	311.800	
635	137.100	434.200	
Drainage pipe PE (Geberit)			
32	0.273	0.804	0.32 ③
40	0.348	1.255	0.40 ③
50	0.443	1.963	0.50 ③
56	0.500	2.463	0.56 ③
63	0.566	3.116	0.63 ③
75	0.679	4.416	0.75 ③
90	0.952	6.360	0.90 ③
110	1.432	9.503	1.10 ③
125	1.817	12.271	1.25 ③
140	2.287	15.391	1.40 ③
160	3.004	20.106	1.60 ③
200	3.830	31.457	2.00 ③
250	6.019	49.150	2.50 ③
Drainage pipe, hard PVC			
50	0.244	1.284	0.50
63	0.308	1.998	0.60
75	0.490	3.930	0.75
110	1.025	8.006	1.10
125	1.351	12.430	1.25
160	2.158	18.031	1.60

Copper pipes			
Pipe outer diameter Ø ④ [mm]	Pipe weight (empty) [kg/m]	Pipe weight (water filled) [kg/m]	Support spacing max. [m]
Copper pipes DIN EN 1057 and 12449, (bright rolled)			
10	0.252	0.302	≤ 0.50
12	0.308	0.387	
15	0.391	0.524	≤ 1.00
18	0.475	0.676	
22	0.587	0.901	≤ 1.50
28	1.110	1.601	
35	1.420	2.214	
42	1.700	2.894	≤ 2.00
54	2.910	4.873	
64	3.470	6.296	
70	3.800	7.219	
74	4.030	7.877	≤ 2.00 -3.00
80	4.360	8.894	
104	5.700	13.550	
125	10.200	21.316	≤ 2.00 -3.00
131	10.700	22.966	

① For pipe clamps with DGM the additional dimensions of the rubber must be considered → See page 49

② Manufacturers of cast iron require that each pipe section be supported at least twice and corner elements i.e. shaped pipes each have a dedicated support.

③ According to manufacturer 10 × Ø.

④ For pipes with standard wall thickness.

⑤ Observe the capacity of the pipe clamps; reduce the span if required.

HALFEN FLEXIBLE FRAMING CONSTRUCTIONS

Pipe Dimensions







Pipe Dimensions																
Threaded pipe DIN EN 10255 (medium and heavy)			Seamless steel pipe DIN EN 10220 DIN 2460 heating pipe		Insulated copper pipe Wicu-Pipe Standard with web coat		Bright copper pipe DIN EN 1057	Steel drainage pipe DIN 19 530 Loro. Steel plastic coated		Cast iron drain pipe GA DIN 19 500 and SML (old version)		Eternit-pipe DIN 19 830 (prior version)		PVC DIN 19531-10 PP DIN 19 560-10 ABS DIN 19 561-10 Rotstrich HT		
DN	Inches	Da	DN	Da	pipe Da	insul. Da	DN	DN	Da	DN	Da	DN	Da	DN	Da	
							12									
							15									
10	3/8	17.2	10	17.2	12	16										
15	1/2	21.3	15	21.3	15	19	18/22									
20	3/4	26.9	20	26.9	18/22	23/27	28									
25	1	33.7	25	33.7	28	33	35							30	32	
					35	40										
32	1 1/4	42.4	32	44.5			42	40	42					40	42.5	
40	1 1/2	48.3	40	48.3	42	48				40	48					
			46	51										50	50	
			50	57			54	50	53	50	58					
50	2	60.3	50	60.3	54	60					60					
			57	63.5			64/65					50	64			
65	2 1/2	76.1	65	76.1			76	70	73	70	78			70	75	
											80					
			76	82.5			85					70	84			
80	3	88.9	80	88.9			89									
			94	101.6			100	100	102							
			100	108						100	110			100	110	
100	4	114.3	100	114.3								100	116			
			113	121												
				127			125								125	125
			125	133			133	125	133	125	133					
											137					
125	5	139.7	125	139.7								125	141			
			150	159			159	150	159	150	160				150	160
150	6	165.1	150	168.3								150	168			
				177.8												
			175	193.7												
															200	200
										200	210					
			200	219.1			219	200	219			200	220			
				267												
			250	273						250	274	250	274			
				298.5												
				318												
			300	323.9						300	326	300	326			
			350	355.6						350	355					
			400	406.4												
										400	429					
			500	508												
										500	532					

DN = nominal diameter; Da = outer pipe diameter

Dimensions in mm (in inches, where stated)

HALFEN FLEXIBLE FRAMING CONSTRUCTIONS

Pipe Dimensions, Selection of Pipe Clamps

Pipe Dimensions													
PE DIN 19 535-10 (Geberit, Akatherm, Riamer, Supralen)		PVC Drainage pipe DIN 19 531		PVC Pressure pipe DIN 19 532 and DIN 8062		PE - Soft-pressure pipe DIN 19 533 (prior version) (Supralen)							
DN	Da	DN	Da	DN	Da	DN	Da	Ø D [mm]	Ø D [mm]	Ø D [mm]	Ø D [mm]	Ø D [mm]	Ø D [mm]
				10	16			17					
				15	20			21.5		21.5			
								27	42.5	27	42.5		
	32	25	32	25	32	20	32	33.5	48.5	33.5	48.5		
	40	32	40	32	40	25	40	42.5	56	42.5	56		
								42.5	56	42.5	56		
								48.5	64	48.5	64		64
40	50	50	50	40	50	32	50	50	64	50	64		64
50	56							56	64	56	64		64
								60	77	60	77		77
60	63	60	63	50	63	40	63	64	80	64	80	64	80
70	75	70	75	65	75	50	75	77	89	77	89	77	89
								80	96	80	96	80	96
								84	100	84	100	84	100
80	90		90	80	90		90	89	105	89	105	89	105
								100	116	100	116	100	116
100	110	100	110	100	110	65	110	110	125	110	125	110	125
								116	131	116	131	116	131
								125	141	125	141	125	141
125	125	125	125	125	125	80	125	125	141	125	141	125	141
								131	150	131	150	131	150
								137	150	137	150	137	150
	140		140		140			141	157	141	157	141	157
150	160	150	160	150	160			160	176	160	176	160	176
								168	185	168	185	168	185
								176	185	176	185	176	185
								200	212	200	212	200	212
200	200	200	200	200	200			200	212	200	212	200	212
								212	225	212	225	212	225
								218	235	218	235	218	235
250	250								267		267		267
								267	285	267	285	267	285
								273	285	273	285	273	285
300	315	300	315						326		326		326
								326	340	326	340	326	340
								355		355			
400	400	400	400					400	420	400	420		
								406	420	406	420		
								429		429			
								508	525	508	525		
								532		532			

DN = nominal diameter; Da = outer pipe diameter

Ø D = nominal clamp diameter (see table pages 41f.)

HALFEN FLEXIBLE FRAMING CONSTRUCTIONS

Pipe Fixing under Bridges

Regulations, standards and basic rules

Reference drawings for civil engineering structures (RIZ-Ing), Published 2015 planning requirements for the drainage of bridges

- Mandatory drawings WAS 5, 6, 13 and 15.
- Execution according to the annex for technical-conditions for contracts, (*ZTV-Ing 8-5 Zusätzlichen Technischen Vertragsbedingungen*).

Additional technical contracting conditions for civil engineering structures (German regulation ZTV-ING), Publ. 2017, part 8, section 5:

"Pipe Supports and fixing connections (...) must be made of stainless steel grade A4 or A5 material no 1.4401 or 1.4571 according to EN 10088 and EN ISO 3506."

Standard catalogue of work specifications (STLK)

The standard catalogue of work specifications for water structures (STLK), issued by the German Federal ministry for transport, and digital communication (*BMVI - Bundesministerium für Verkehr und digitale Infrastruktur*) standardizes the text required for the bidding procedure in water structure projects. It expands on the contract procedures for construction work in Germany as well as on the technical regulations for excavation projects, especially the annex for technical-conditions for contracts, (*ZTV-ING*).

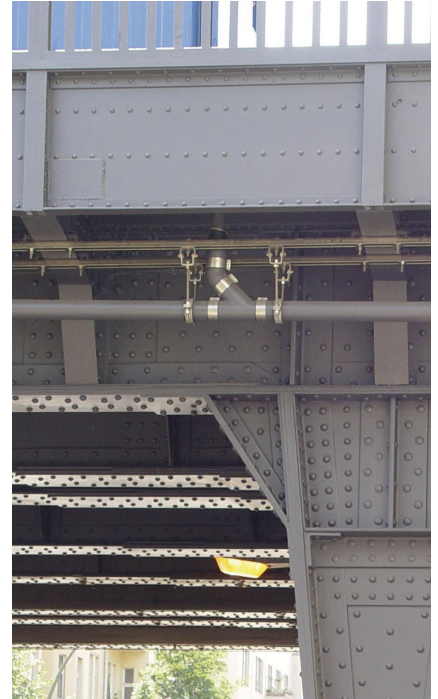

Support structures for pipes under bridges, which are not covered by WAS regulations

The large range of HALFEN Channels, T-bolts and accessories in stainless steel grade A4 enables support structures, even with difficult boundary conditions, to be successfully completed according to customer requirements. We offer technical support for clients; we supply efficient solutions for various types of projects.

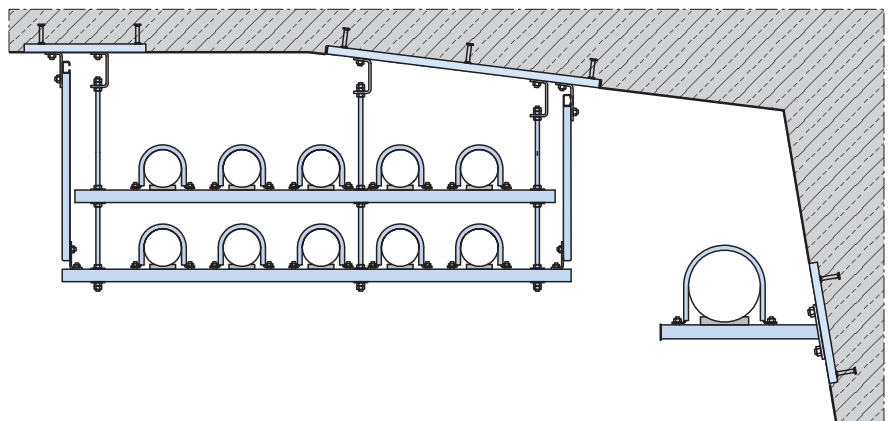

For more information please contact us

Please see the back page of this catalogue for regional contact addresses.
www.halfen.com

HALFEN FLEXIBLE FRAMING CONSTRUCTIONS

Pipe Fixing under Bridges

Specification examples

WAS 5 or WAS 6

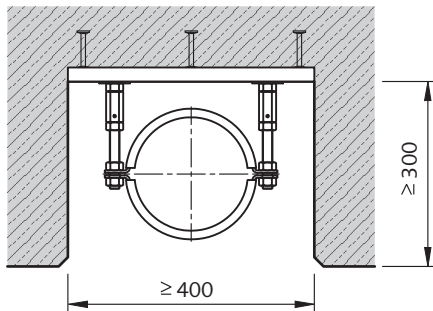

Specification text:

HALFEN Pipe fastener according to WAS 6.
Supply and install _____ piece(s) HALFEN Pipe fastener according to WAS 6, material stainless steel W 1.4571/ 1.4401 (A4) for DN ____.

WAS 15

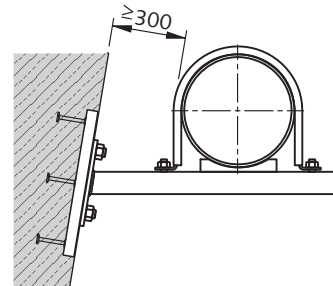

Specification text:

HALFEN Pipe fastener according to WAS 15.
Supply and install _____ piece(s) HALFEN Pipe fastener according to WAS 15, material stainless steel W 1.4571/ 1.4401 (A4) for DN ____.

WAS 13 Figure 1 – Rigid fixing

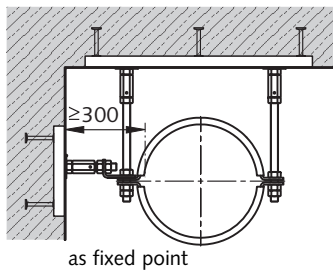

Specification text:

HALFEN Pipe fastener (rigid) according to WAS 13.
Supply and install _____ piece(s) HALFEN Pipe fastener according to WAS 13, material stainless steel W 1.4571/ 1.4401 (A4) for DN ____ with/without fixed point.

WAS 13 Figure 2

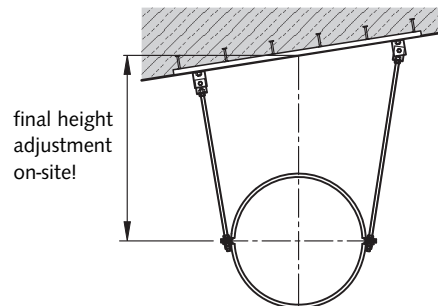

Specification text:

HALFEN Pipe fastener according to WAS 13.
Supply and install _____ piece(s) HALFEN Pipe fastener according to WAS 13, material stainless steel W 1.4571/ 1.4401 (A4) for DN ____.

HALFEN FLEXIBLE FRAMING CONSTRUCTIONS

Specification Texts

1. HALFEN Pipe clamp suspension

Type Beta, zinc plated for pipe DN__ Da__

Supply and install __ piece(s) HALFEN Pipe clamp suspension, consisting of pipe clamp type Beta __, in finish __, with installation rubber - or - without installation rubber and threaded rod M12, L = 1000 mm with hexagonal rod coupler SKM M12, with T-head bolts for fixing on pre-installed HALFEN Channel __/__ or for fixing with dowel.

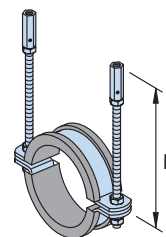

2. HALFEN Pipe clamp suspension

Type Delta, zinc coated for pipe DN__ Da__

Supply and install __ piece(s) HALFEN Pipe clamp suspension, consisting of pipe clamp type Delta __, in finish __, with installation rubber - or - without installation rubber and threaded rod M16, L = 1000 mm with hexagonal rod coupler SKM M16, with T-head bolts for fixing on pre-installed HALFEN Channel __/__ or for fixing with dowel.

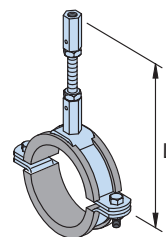

3. HALFEN Pipe clamp fixing

System HCS RAD for Rohr DN__ Da__

Supply and install __ piece(s) HALFEN Pipe clamp suspension type Alpha HCS - RAD __, in finish __, with installation rubber and pipe rest - or - without installation rubber with/or without pipe rest incl. T-head bolts for fixing of pipes to HALFEN Channels __/__.

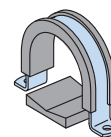

4. HALFEN Pipe support

Pipe support HRG for Pipe DN__ Da__

Supply and install __ piece(s) HALFEN Pipe support HRG __, in finish __, as fixed support for assembly using T-head bolts or as a floating support with lift-off safety device and T-head bolts, appropriate for the anticipated forces.

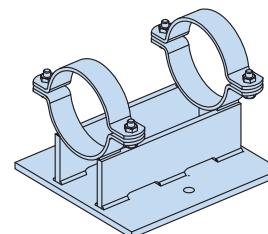

5. HALFEN Lift off safety device

Lift off safety device AHS

Supply and install __ piece(s) HALFEN Lift-off safety device type AHS __, finish __, as guides for pipe T-supports type HRG __.

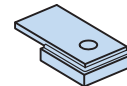

6. HALFEN Cantilever

Supply and install __ piece(s) HALFEN Cantilever type KON __, for fixing pipes or other components.

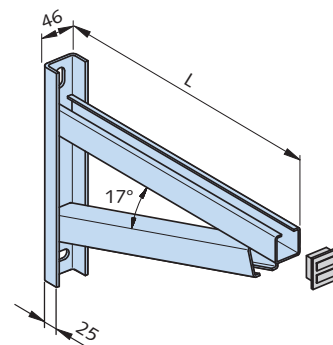



Leviat®

Innovative engineered products
and construction solutions that
allow the industry to build safer,
stronger and faster.



Contact Leviat worldwide

Australia

Unit A, 1 Heinrich Close,
Eastern Creek, Sydney, NSW 2766
Tel: +61 - 2 8808 3100
Email: info.au@leviat.com

Austria

Leonard-Bernstein-Str. 10
Saturn Tower, 1220 Wien
Tel: +43 - 1 - 259 6770
Email: info.at@leviat.com

Belgium

Industrielaan 2
1740 Ternat
Tel: +32 - 2 - 582 29 45
Email: info.be@leviat.com

China

Room 601 Tower D,
Vantone Centre
No. A6 Chao Yang Men Wai Street
Chaoyang District
Beijing P.R. China 100020
Tel: +86 - 10 5907 3200
Email: info.cn@leviat.com

Czech Republic

Pekařská 695/10a
155 00 Praha 5
Tel: +420 - 311 - 690 060
Email: info.cz@leviat.com

Finland

Vädursgatan 5
412 50 Göteborg / Sweden
Tel: +358 (0)10 6338781
Email: info.fi@leviat.com

France

6, Rue de Cabanis
31240 L'Union
Tel: +33 (0)5 34 25 54 82
Email: info.fr@leviat.com

Germany

Liebigstrasse 14
40764 Langenfeld
Tel: +49 - 2173 - 970 - 0
Email: info.de@leviat.com

India

Unit S4, 902, A Wing,
Lodha iThink Techno Campus Building,
Panchpakhadi, Pokharan Road 2,
Thane, 400606
Tel: +91-022 695 33700
Email: info.in@leviat.com

Italy

Via F.lli Bronzetti 28
24124 Bergamo
Tel: +39 - 035 - 0760711
Email: info.it@leviat.com

Malaysia

28 Jalan Anggerik Mokara 31/59
Kota Kemuning,
40460 Shah Alam Selangor
Tel: +603 - 5122 4182
Email: info.my@leviat.com

Netherlands

Oostermaat 3
7623 CS Borne
Tel: +31 - 74 - 267 14 49
Email: info.nl@leviat.com

New Zealand

246D James Fletcher Drive, Otahuhu,
Auckland 2024
Tel: +64 - 9 276 2236
Email: info.nz@leviat.com

Philippines

27F Office A, Podium West Tower,
12 ADB Avenue, Ortigas Center
Mandaluyong City, 1550
Tel: +63 - 2 7957 6381
Email: info.ph@leviat.com

Poland

Ul. Obornicka 287
60-691 Poznań
Tel: +48 - 61 - 622 14 14
Email: info.pl@leviat.com

Singapore

10 Benoi Sector,
Singapore 629845
Tel: +65 - 6266 6802
Email: info.sg@leviat.com

Spain

Polígono Industrial Santa Ana
c/ Ignacio Zuloaga, 20
28522 Rivas-Vaciamadrid
Tel: +34 - 91 632 18 40
Email: info.es@leviat.com

Sweden

Vädursgatan 5
412 50 Göteborg
Tel: +46 - 31 - 98 58 00
Email: info.se@leviat.com

Switzerland

Grenzstrasse 24
3250 Lyss
Tel: +41 (0)800 22 66 00
Email: info.ch@leviat.com

United Arab Emirates

RA08 TB02, PO Box 17225
JAFZA, Jebel Ali, Dubai
Tel: +971 (0)4 883 4346
Email: info.ae@leviat.com

United Kingdom

President Way,
President Park,
Sheffield S4 7UR
Tel: +44 - 114 275 5224
Email: info.uk@leviat.com

USA / Canada

6467 S Falkenburg Road
Riverview, FL 33578
Tel: (800) 423-9140
Email: info.us@leviat.us

For countries not listed

Email: info@leviat.com

Notes regarding this document

© Protected by copyright. The information in this publication is based on state-of-the-art technology at the time of publication. In every case, project working details should be entrusted to appropriately qualified and experienced persons. Leviat shall not accept liability for the accuracy of the information in this document or for any printing errors. We reserve the right to make technical and design changes at any time. With a policy of continuous product development, Leviat reserves the right to modify product design and specification at any time.

Leviat®

Imagine. Model. Make.

Leviat.com