

## Installation Guide MM 63 Remedial Wall Tie

Drill a hole through the outer leaf and into the inner to a minimum depth of 60mm using a 10mm drill bit. Remove dust and debris.

Screw the male threaded portion of the tie into the female threaded part of the setting tool. Note a gap of at least 1mm must be maintained between the nut and the end of the setting tool.

Insert the wall tie into the hole and turn in a clockwise direction whilst gently pushing into the back of the hole. Continue turning unit hand tight. (1.2 - 2Nm)

To remove the fixing tool, hold the single handle whilst turning the T handle anti-clockwise. Unscrew fixing tool from wall tie. Close together the setting tool prior to setting additional ties.

Carry out pull test to tie on inner leaf if required.

To fix the outer leaf insert the hexagonal setting tool over the small nut on the tie and turn clockwise until hand tight. (1.2 - 2Nm) Remove setting tool.

Make good the outer brick using colour matched mortar or mastic.

### Ancon 63 Range

Cavity Width (mm)	Tie Lengths (mm)	Drill Diameter (mm)	Drill Depths (mm)
50-75	200	10	60 min.
76-100	225	10	60 min.
101-125	250	10	60 min.
126-175	300	10	60 min.

**Spacings:** Accepted practice is to follow BS 5628 i.e. 900mm horizontally and 450mm vertically in a staggered pattern with 300mm vertical centres around openings within 225mm of the opening. For cavities over 100mm, horizontal spacing may need to be reduced to 450mm

### Failure Loads (Pull-Out)

Base Material	Compressive Strength (N/mm <sup>2</sup> )	Failure Load (kN)
Hard Brick (Accrington Nori)	80	5.6
Soft Brick (Yellow Imperial)	30	3.8
Portland Stone	20	5.3
Dense Aggregate Block	7	1.9

**Note:** Test results are a mean of 5 tests



MM63 Remedial Tie



Inner Setting Tool

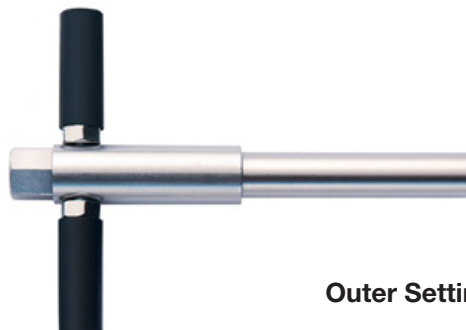

Outer Setting Tool

© Leviat, 2020

The Construction applications and details provided in this guide are indicative only. In every case installation should be entrusted to appropriately qualified and experienced persons. Normal handling precautions should be taken to avoid physical injury. Leviat cannot be held responsible for any injury as a result of using our products, unless such injury arises as a result of our negligence.