

## Installation Guide Ancon Steelgrip

Ancon Steelgrip is designed for fixing Ancon masonry support systems to square or rectangular hollow steel sections. It can also be used with other steel sections where access is only available from the front.

It is a high performance fixing available in one size (M12).

Steelgrip includes a serrated washer, which matches the serrations at the back of the Ancon bracket. With the bracket in position, Steelgrip is inserted through the vertical slot in the bracket and into the pre-drilled hole in the Hollow Section. It is then simply tightened to the correct torque.

### Performance

The safe working loads given in the table below are based on a FOS 3:1.

### Installation

1. Drill a hole in the steel member. See table below for hole diameter and minimum edge distance.
2. With the bracket in place, insert the Steelgrip through the vertical slot ensuring that the serrations on the washer are horizontal and will mesh with the serrations at the back of the bracket.
3. Adjust the height of the bracket, and if necessary insert shims behind the bracket up to a maximum thickness of 16mm. An isolation membrane will normally be positioned between the face of the steel edge member and the stainless steel bracket/shim.
4. Tighten the Steelgrip to required torque using a calibrated torque wrench. See table below for tightening torque.

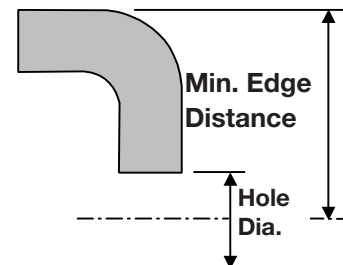
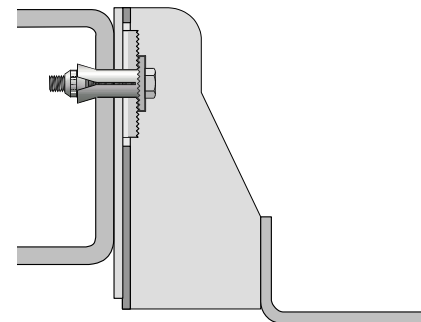

**5mm-28mm  
including shims**

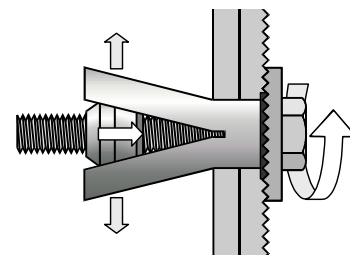
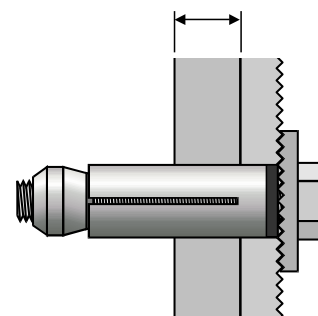

Technical Data	M12
SWL Tension	15kN
SWL Shear	10kN
Hole Diameter	20mm
Min. Edge Distance	25mm
Tightening Torque	80Nm

© Leviat, 2020

The Construction applications and details provided in this guide are indicative only. In every case installation should be entrusted to appropriately qualified and experienced persons. Normal handling precautions should be taken to avoid physical injury. Leviat cannot be held responsible for any injury as a result of using our products, unless such injury arises as a result of our negligence.