

HALFEN CONCRETE FAÇADE ANCHOR SYSTEMS

Technical Product Information

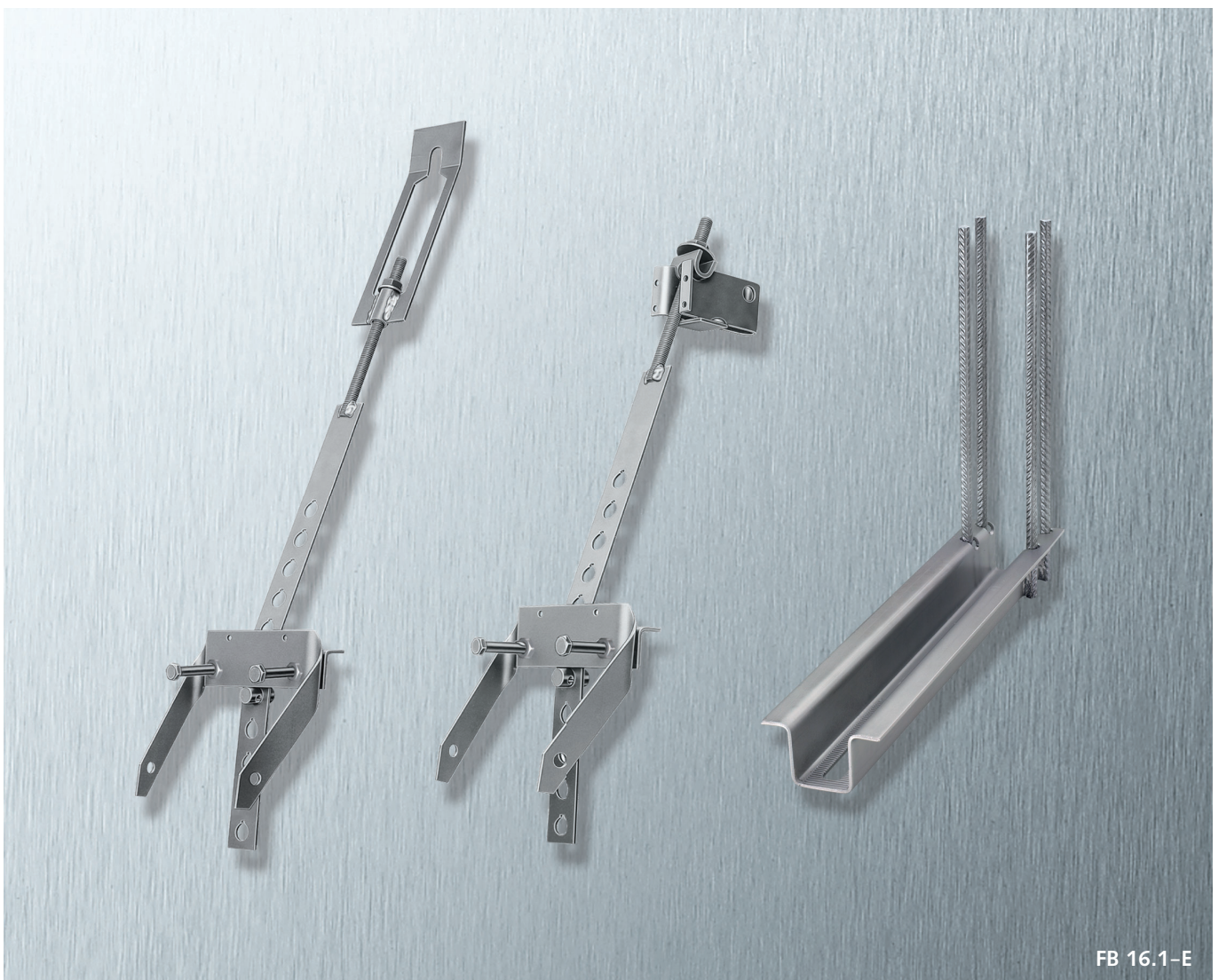

- CE marking acc. to EN 1090-1, EN 1090-2 for FPA and BRA
- Larger wall cavity
- Standard solution FPA-5S for lateral installation to columns



- FPA-Software with integrated FE kernel
- BRA-L4 Parapet corbel in Lean Duplex

Leviat

We imagine, model and make engineered products and innovative construction solutions that help turn architectural visions into reality and enable our construction partners to build better, safer, stronger and faster.

Leviat is a world leader in connecting, fixing, lifting and anchoring technology.

From the build of new schools, hospitals, homes and infrastructure, to the repair and maintenance of heritage structures, our engineering skills are making a difference around the world.

We provide technical design assistance at every stage of a project, from initial planning to installation and beyond.

Our technical support services range from simple product selection through to the development of a fully customised project-specific design solution.

Every promise we make locally, has the commitment and dedication of our global team behind it. We employ almost 3,000 people at 60 locations across North America, Europe and Asia-Pacific, providing an agile and responsive service worldwide.



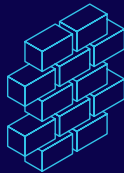
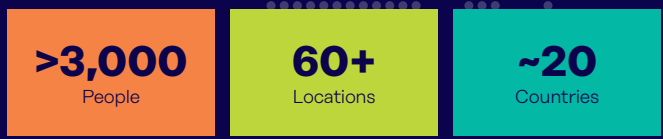

Façade Support & Restraint

Systems for the safe and thermally-efficient fixing of the external building envelope, including brick and natural stone, insulated sandwich panels, curtain walling and suspended concrete façades, and also the repair and strengthening of existing masonry installations.

- Masonry Support Systems
- Windposts
- Lintels
- Brick Slip Systems
- Wall Ties & Restraints
- Masonry Reinforcement
- Natural Stone Façade Systems
- Cavity Trays
- Sandwich Panel anchor
- Suspended concrete façade
- Masonry Repair

Other areas of expertise:

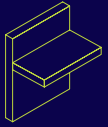

Structural Connections

Systems to form robust, efficient connections, and continuity of concrete reinforcement as necessary, between walls, slabs, columns, beams and balconies, providing structural integrity as well as enhanced thermal and acoustic performance.

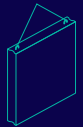

Lifting & Bracing

Systems for the safe and efficient transportation, lifting and temporary bracing of cast concrete elements and tilt-up panels before permanent structural connections are made.

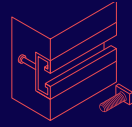

Anchoring & Fixing

Systems for fixing secondary fixtures to concrete, including anchor channels, bolts and inserts; also tension rod systems for roofs and canopies.



Formwork & Site Accessories

Non-structural accessories that complement our engineered solutions and help keep your construction environment operating safely and efficiently, including moulds for casting standard and special concrete elements and construction essentials such as reinforcing bar spacers.

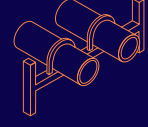

Industrial Technology

Mounting channels, pipe clamps and other versatile framing systems that provide safe fixing in a wide range of industrial applications.

Leviat product ranges:

Ancon | Aschwanden | Connolly | Halfen | Helifix | Isedio | Meadow Burke | Modersohn | Moment | Plaka | Scaldex | Thermomass

HALFEN CONCRETE FAÇADE ANCHOR SYSTEMS

Global Market Leader in Fixing Systems for Concrete Façades



German Federal Ministry for environment,
nature conservation and reactor safety,
Berlin
(*Bundesministerium für Umwelt,
Naturschutz und Reaktorsicherheit*)

Product: HALFEN FPA,
HALFEN DS

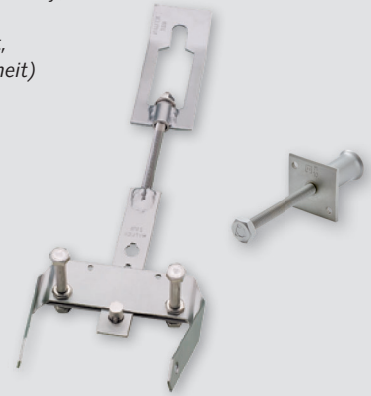

Alexa Shopping Centre,
Berlin

Product: HALFEN FPA,
HALFEN DS



HALFEN CONCRETE FAÇADE ANCHOR SYSTEMS

Contents

General

-	Software	4
-	Basics of design	5



Precast panel anchors

-	FPA-3	6
-	FPA-5, FPA-5Z	8
-	FPA-5A	9
-	FPA-5AZ	10
-	FPA-5S	11
-	Anchor design	12
-	Dimension tables for perforated straps	13
-	Installation of the FPA-3 and FPA-5 Façade panel anchors	16
-	Mounting of the FPA-3 and FPA-5 Façade panel anchors	17

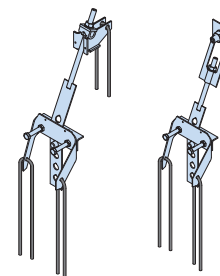

Top fixing dowels

-	WPA-A, WPA-B Top fixing dowels	18
-	Anchor dimensioning	18
-	Assembly and installation instructions	19

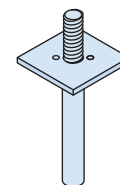

Parapet corbels

-	BRA-L4 Parapet corbels	20
-	Dimensioning	22
-	Assembly and installation instructions	23
-	Installation accessories	25

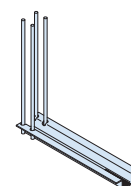

Horizontal anchorage / Dowel restraints

-	Type overview	27
-	Spacer bolts	28
-	Dimensions of spacer bolts	29
-	Load capacities of spacer bolts	30
-	LD Adjustable restraint	31
-	SPV Restraint with turnbuckle	33
-	WDK Wind anchor	34
-	WDI Wind anchor	35
-	HKZ Restraint tie	36
-	HFV Dowel restraints	38
-	ULZ Universal tie	41

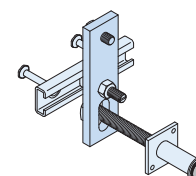
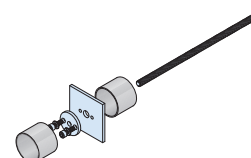

Building physics

-	Building physics	44
---	------------------	----

Invitation to tender

-	FPA-3 / FPA-5 / DS 13 / LD	45
-	HFV (plastic / stainless) / BRA-N / BRA-NJ	46

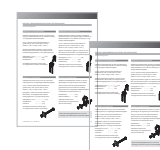

Other HALFEN Systems for concrete façades

-	Sandwich panel anchors	47
-	Lifting anchor systems	47

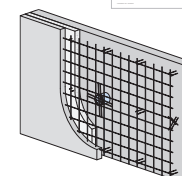

HALFEN CONCRETE FAÇADE ANCHOR SYSTEMS

Software

Calculation programs help to shorten planning time

The HALFEN BRA and FPA Dimensioning programs are user-friendly and easy to learn.

Façade dimensions, parapet slab dimensions, selection of anchor types and other options are entered for calculation.

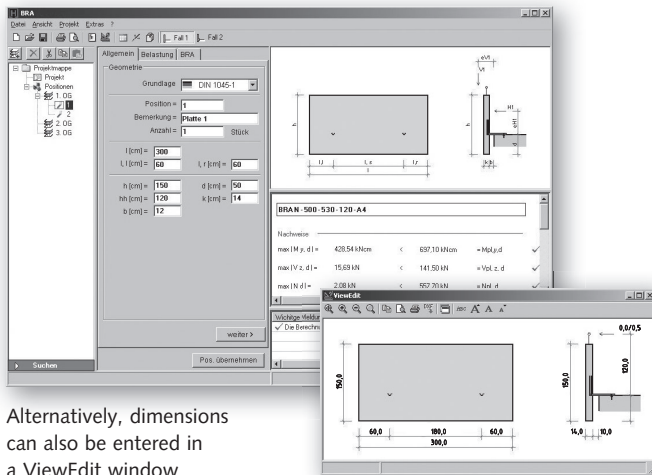

Alternatively, dimensions can also be entered in a ViewEdit window.

BRA calculation result:

- parapet corbel profile description
- loads per profile
- anchor recommendation
- printout of the results with a drawing
- printout of the static calculation

New features in the BRA-Software:

- stainless-steel reinforcement option allows thinner parapet design
- variable entry of concrete cover
- integrated tool for wind loads



All software has easy to use online help; including the FPA and the BRA program.

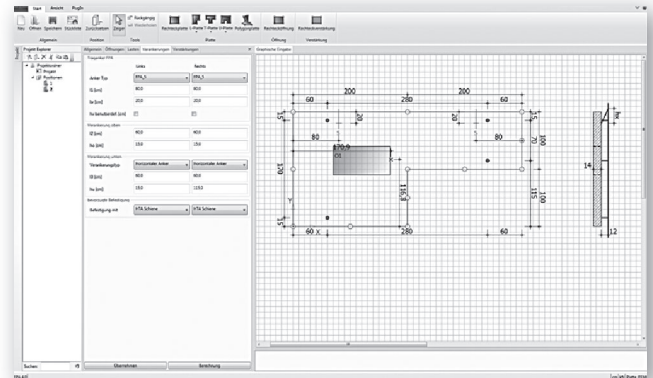

FPA calculation result:

- description of the calculated anchorage type
- loads per anchor
- description of the spacer bolts or the dowel restraint fitting
- loads for horizontal restraints
- wind-suction protection where required
- printout of the results incl. a drawing

New features in the FPA-Software:

- dimensioning of non-symmetrical slab geometry and anchor layout with the integrated FE kernel
- enlarged wall cavities for FPA bolts and spacer bolts
- integration of all accessories (horizontal restraints, suction protection, fastening devices)
- default slab shapes (U, L, T, etc.)
- output of parts listed separately as installation (precast) and (on-site) assembly parts
- integrated tool for wind loads
- transfer of dowel restraint load data
- element plan with anchor positions and type identification

You can download our programs from the Internet under www.halfen.com/downloads or order our latest "Dimensioning software" DVD free of charge by post.



HALFEN CONCRETE FAÇADE ANCHOR SYSTEMS

Global Market Leader in Fixing Systems for Concrete Façades

Safe and economical planning

In this catalogue, you will find all the necessary planning, calculation information and details required for the constructive design of concrete façades as well as information for suitable anchors and installation accessories.

If required our team is available with its extensive experience and comprehensive range of products to assist all the way through to final installation. This includes initial planning, static consultation and comprehensive calculation.

In addition to our technicians, our support and consultation team who are able to personally assist with your projects, we also provide easy to use software to help calculate your projects.

Basic planning information for concrete façades

Innovative production methods in precast concrete plants and up to date self-compacting concrete allow contemporary surface textures and therefore, high quality, economical functional and good quality precast-concrete components.

These façades components are secured to the load-bearing structure of the building as separate, thin façade elements.

Following distinction in construction type is made:

1. Suspended panels

- architectural variety
- economical
- quick installation
- high insulation thicknesses

2. Angled panels

- aesthetic building finishings
- no thermal bridges
- safe installation and storage

3. Parapet panels

- higher level of prefabrication
- variety in architecture
- safe and quick installation

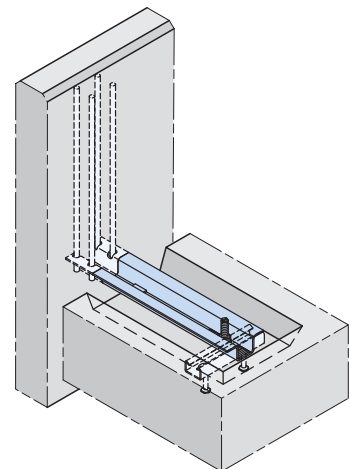
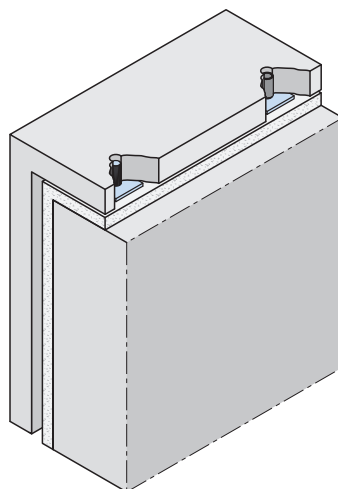
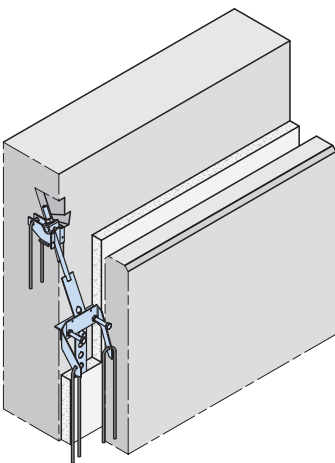

HALFEN CONCRETE FAÇADE ANCHOR SYSTEMS

HALFEN FPA-3 Façade Panel Anchors

FPA-3 Façade panel anchors

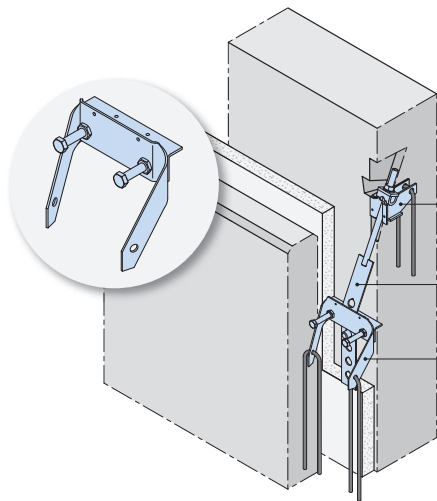

Component parts e.g. FPA-3

FPA - 3 - R (cast-in structural connection):
Support arm and recess former

FPA - 3 - M (assembly component):
Perforated strap with locating pin,
nut, washer and locking bolts

FPA - 3/5 - E (cast-in panel connection):
Cast-in part with shaped bracket and recess
former

FPA-3/5-E Cast-in part for pre-fabricated elements

The cast-in parts for the façade panel anchors are the same for all types and are selected from the following table. The colour codes and the assembly and installation instructions can be found on pages 16-17.

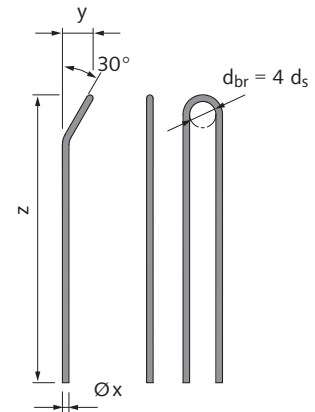
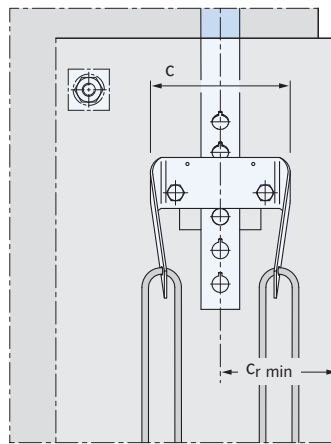
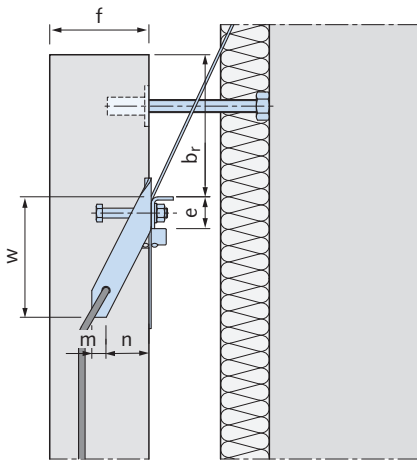

The stirrup for load group ≥ 34 is bent 30° degrees as shown

Cast-in panel connection FPA-3/-5-E for pre-fabricated element [mm]

Load group	Load capacity $F_{V,Rd}$ [kN]	Cast-in part FPA-3/5-E suitable for FPA-3, FPA-5, FPA-5Z, FPA-5A, FPA-5AZ								Reinforcement stirrup, B500A, B500B, (supplied by others)		
		f min	b_r min	c_r min	c	e	m	n	w	$\varnothing x$	y	z
5.0	6.75	70 ^①	50	107	122	22	11	40	107	6	-	250
8.0	10.80	70 ^①	60	112	137	28	13	40	116	6	-	250
11.5	15.53	80 ^①	70	122	142	36	15	46	133	8	-	250
16.0	21.60	80 ^①	80	132	170	39	18	52	148	8	-	350
22.0	29.70	90	100	132	170	42	21	52	151	8	-	400
34.0	45.90	100	110	160	210	52	25	52	164	10	25	500
46.0	62.10	115	140	180	213	62	30	50	166	12	42	500
56.0	75.60	125	150	180	218	69	35	50	173	12	52	600

① Only possible when complying to minimal concrete cover (no tolerance allowance)

HALFEN CONCRETE FAÇADE ANCHOR SYSTEMS

HALFEN FPA-3 Façade Panel Anchors

FPA-3 Façade panel anchors

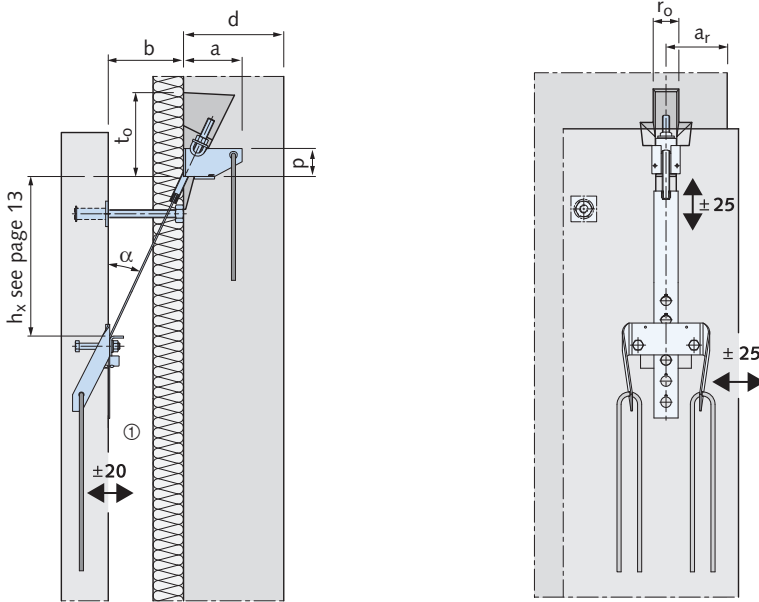

Dimensions in [mm]

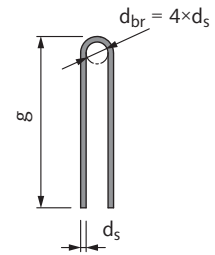

B500A, B500B Steel reinforcement stirrups are not included in the scope of delivery.

① Horizontal adjustment using spacer bolt, see page 28 f.

Please order spacer bolt and sleeve separately, see page 28

Components of FPA-3

FPA - 3 - R (cast-in structural connection):
Support arm and recess former

FPA - 3 - M (assembly component):
Perforated strap with locating pin, nut, washer and locking bolts

FPA - 3 - E (cast-in panel connection):
Cast-in part with shaped bracket and recess former

FPA - 3 - G (complete set) components:

FPA - 3 - R
+ **FPA - 3 - M**
+ **FPA - 3 - E**

Order example

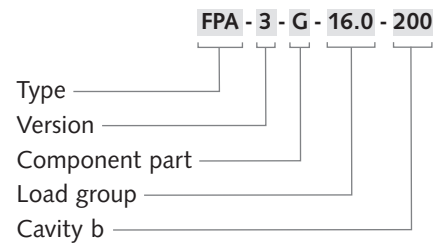

Dimension table FPA-3-R

Load group	Load capacity $F_{V,Rd}$ [kN]	Perforated strap angle α ①	Installation depth a [mm]	d_{min} [mm]	Lateral edge distance $a_{r,min}$ ② [mm]	t_o [mm]	r_o [mm]	p [mm]	Stirrup	
									d_s [mm]	g [mm]
5.0	6.75	25.0°	81	100	70	121	38	38	6	200
8.0	10.80	25.0°	85	115	80	130	40	38	6	200
11.5	15.53	25.0°	96	125	90	150	45	50	8	200
16.0	21.60	25.0°	115	140	120	165	50	55	8	250
22.0	29.70	22.5°	134	160	130	179	60	59	10	250
34.0	45.90	22.5°	155	180	150	202	70	72	12	300
46.0	62.10	20.0°	190	240	170	236	80	86	16	350
56.0	75.60	20.0°	213	300	200	255	94	95	16	400

① For more information about perforated straps, see page 13-15

② For smaller values for a_r , please contact our Technical Support Team

HALFEN CONCRETE FAÇADE ANCHOR SYSTEMS

HALFEN FPA-5 and FPA-5Z Façade Panel Anchors

FPA-5 Façade panel anchors

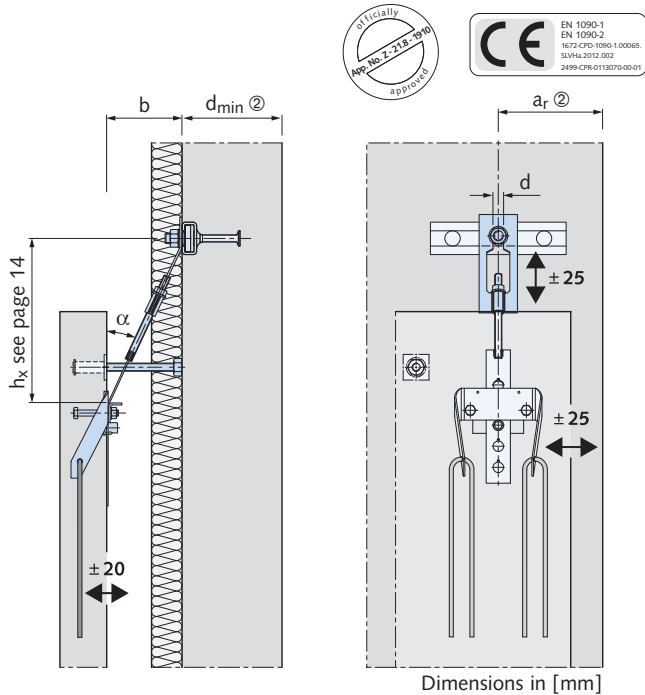

FPA-5Z Façade panel anchors

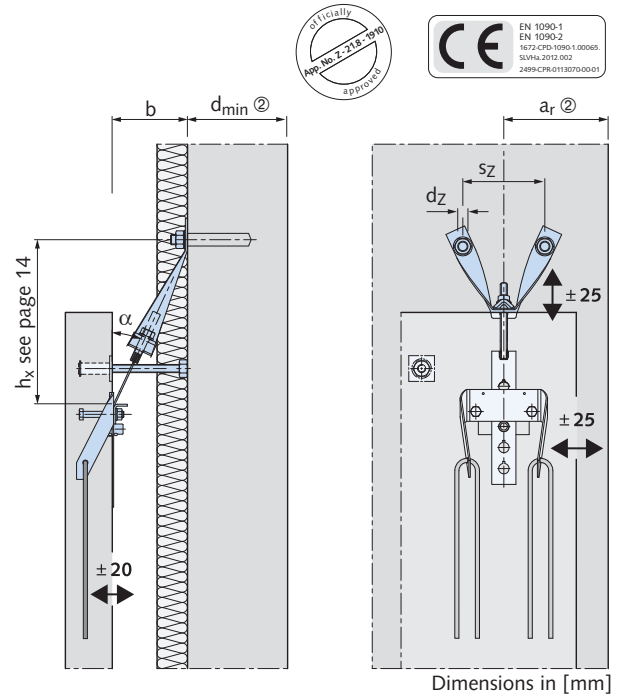

FPA-5 Components

FPA - 5 - M (assembly component):
Perforated strap with nut, washer, locking bolts and suspension

FPA - 3/5 - E (cast-in panel connection):
Cast-in element with shaped bracket and recess former

FPA - 5 - G (complete set) components:

- FPA - 5 - M**
- + **FPA - 5 - E**

Order example

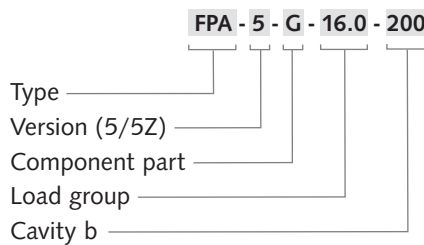

Spacer bolt and sleeve are ordered separately, see page 28

Information on using façade anchors fixings

We recommend using HTA Cast-in channels or tension suitable anchor bolts. Fitness for purpose must be clarified in advance if non-tension zones anchors-bolts are used. All fittings must be calculated for the actual loads.

Dimension table FPA-5 and FPA-5Z

Load group	Load capacity $F_{V,Rd}$ [kN]	Perforated strap angle α for cavity b ^③								Hole diameter, assembly component		S_Z ^④ [mm]
		[mm]								d [mm]	d_z [mm]	
		60	70	80	90	100	110	120	>120			
5.0	6.75	18.5°	21.5°	25.0°	25.0°	25.0°	25.0°	25.0°	25.0°	13	8.5	120
8.0	10.80	18.5°	21.5°	25.0°	25.0°	25.0°	25.0°	25.0°	25.0°	17	10.5	135
11.5	15.53	16.5° ①	19.0°	22.0°	25.0°	25.0°	25.0°	25.0°	25.0°	21	12.5	160
16.0	21.60	14.5° ①	17.0°	19.5°	22.5°	25.0°	25.0°	25.0°	25.0°	21	12.5	160
22.0	29.70	13.5° ①	15.5°	18.0°	20.0°	22.5°	22.5°	22.5°	22.5°	21	16.5	170
34.0	45.90	-	14.0° ①	16.0° ①	18.5°	20.5°	22.5°	22.5°	22.5°	25	22.5	190
46.0	62.10	-	-	-	-	16.0° ①	18.0° ①	20.0°	20.0°	28	25.0	250
56.0	75.60	-	-	-	-	-	15.0° ①	17.0° ①	20.0°	31	25.0	315

① Reduced tolerance range

② d_{min} and a_r depend on the fixing system

③ For more information on perforated straps, see page 14

④ Values may deviate up to 15 mm!

HALFEN CONCRETE FAÇADE ANCHOR SYSTEMS

HALFEN FPA-5A Façade Panel Anchors

FPA-5A Façade panel anchors

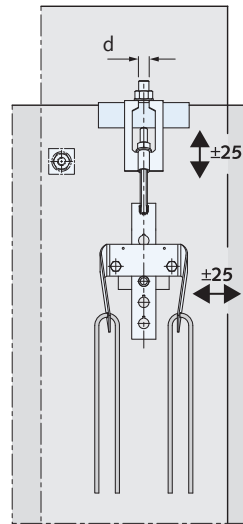
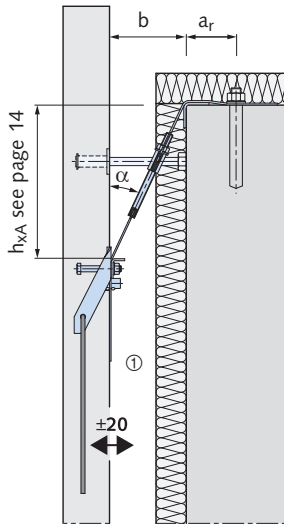

Dimensions in [mm]

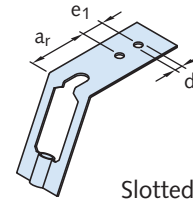

Slotted strap FPA-5A

① Horizontal adjustment using the spacer bolt, see page 28 f.

Spacer bolt and sleeve are ordered separately, see page 28

Components FPA-5A

FPA - 5A - M (assembly component):
Perforated strap with nut and washer, locking bolts, slotted strap and corner protection

FPA - 5A - G (complete set):
FPA - 5A - M
+ **FPA - 5 - E**

FPA - 3/5 - E (cast-in panel connection):
Cast-in part with shaped bracket and recess former

Order example

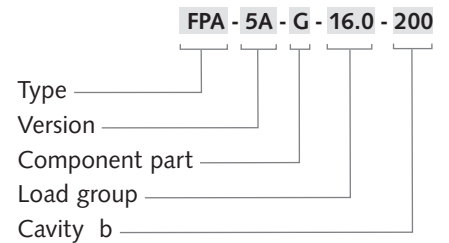

Dimension table FPA-5A

Load group	Load capacity $F_{V,Rd}$ [kN]	Perforated strap angle α for cavity b							Hole diameter, assembly component d [mm]	Only for FPA-5A	
		②								Hole spacing e_1 [mm]	Edge distance a_r [mm]
		60	70	80	90	100	110	≥ 120			
5.0	6.75	18.5°	21.5°	25.0°	25.0°	25.0°	25.0°	25.0°	$\emptyset 11$	24	110
8.0	10.80	18.5°	21.5°	25.0°	25.0°	25.0°	25.0°	25.0°	$\emptyset 13$	28	135
11.5	15.53	16.5° ①	19.0°	22.0°	25.0°	25.0°	25.0°	25.0°	$\emptyset 17$	37	155
16.0	21.60	14.5° ①	17.0°	19.5°	22.5°	25.0°	25.0°	25.0°	$\emptyset 21$	46	210
22.0	29.70	13.5° ①	15.5°	18.0°	20.0°	22.5°	22.5°	22.5°	$\emptyset 21$	46	210
34.0	45.90	-	14.0° ①	16.0°	18.5°	20.5°	22.5°	22.5°	$\emptyset 25$	55	260
46.0	62.10	available on request									
56.0	75.60										

① Reduced tolerance range

② For more information on perforated straps, see page 14

HALFEN CONCRETE FAÇADE ANCHOR SYSTEMS

HALFEN FPA-5AZ Façade Panel Anchors

FPA-5AZ Façade panel anchors

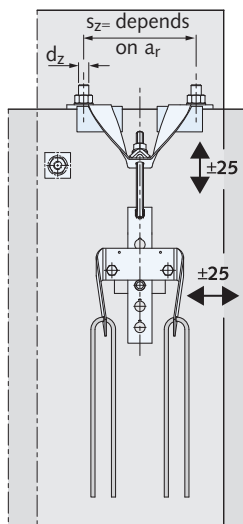
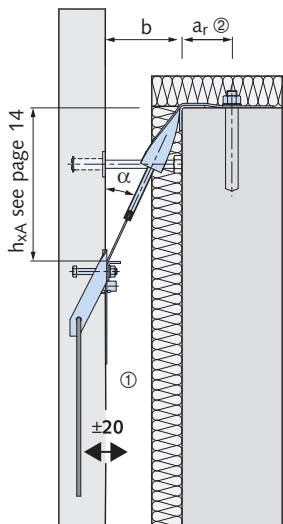

Dimensions in [mm]

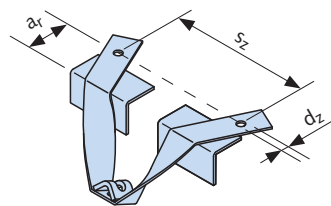

Two-point suspension FPA-5AZ

① Horizontal adjustment using spacer bolt, see page 28 f.

Spacer bolt and sleeve are ordered separately, see page 28

Components of FPA-5AZ

Order example

FPA - 5AZ - M (assembly component):
Perforated strap with nut, washer, locking bolts, two-point suspension and corner protection

FPA - 5AZ - G (complete set):
FPA - 5AZ - M
+ **FPA - 5 - E**

FPA - 3/5 - E (cast-in panel connection):
Cast-in part with shaped bracket and recess former

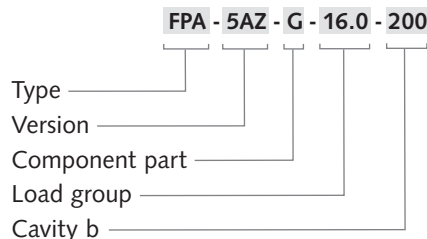

Dimension table FPA-5AZ

Load group	Load capacity $F_{V,Rd}$ [kN]	Perforated strap angle α for cavity b ② [mm]								Hole diameter installation part d_z [mm]	Spreading s_z [mm] at edge distance a_r [mm] ③ ④								$a_{r,max}$ ⑤ [mm]		
		60	70	80	90	100	110	120	≥ 120		60	80	100	120	140	160	180	200		230	280
5.0	6.75	18.5°	21.5°	25.0°	25.0°	25.0°	25.0°	25.0°	25.0°	Ø 8.5	175	190	210							100	
8.0	10.80	18.5°	21.5°	25.0°	25.0°	25.0°	25.0°	25.0°	25.0°	Ø 10.5	190	205	225							110	
11.5	15.53	16.5° ①	19.0°	22.0°	25.0°	25.0°	25.0°	25.0°	25.0°	Ø 12.5	200	220	240	255						135	
16.0	21.60	14.5° ①	17.0°	19.5°	22.5°	25.0°	25.0°	25.0°	25.0°	Ø 12.5	210	230	250	270	290					140	
22.0	29.70	13.5° ①	15.5°	18.0°	20.0°	22.5°	22.5°	22.5°	22.5°	Ø 16.5		235	255	270	290	310				170	
34.0	45.90	-	14.0° ①	16.0°	18.5°	20.5°	22.5°	22.5°	22.5°	Ø 22.5			270	290	305	325	340	360		200	
46.0	62.10					16.0° ①	18.0° ①	20.0°	20.0°	Ø 25.0				320	335	335	370	385	410	230	
56.0	75.60						15.0° ①	17.0° ①	20.0°	Ø 25.0					370	390	405	420	445	485	280

① Reduced tolerance range

② For more information on perforated straps, see page 14

③ Please provide value for a_r when ordering. Dowel load bearing capacity must be verified for the selected position

④ Values may deviate up to 20 mm!

⑤ Larger a_r values are available on request

HALFEN CONCRETE FAÇADE ANCHOR SYSTEMS

HALFEN FPA-5S Façade Panel Anchors

FPA-5S Façade panel anchor

NEW!

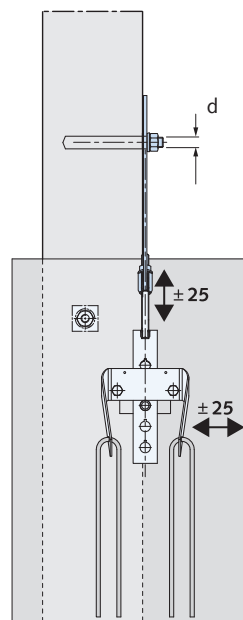
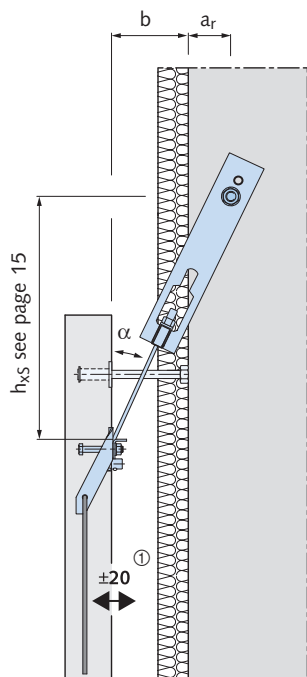

Dimensions in [mm]

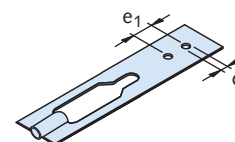

Slotted strap FPA-5S

① Horizontal adjustment using spacer bolt, see page 28 f.

Spacer bolt and sleeve are ordered separately, see page 28

Components of FPA-5S

FPA - 5S - M (assembly component):
Perforated strap with nut and washer, locking bolts and slotted strap

FPA - 5S - G (Complete set):
FPA - 5S - M
+ **FPA - 5 - E**

FPA - 3/5 - E (cast-in panel connection):
Cast-in part with shaped bracket and recess former

Order example

FPA - 5S - G - 16.0 - 200

Type _____
Version _____
Component part _____
Load group _____
Cavity b _____

Dimension table FPA-5S

Load group	Load capacity $F_{V,Rd}$ [kN]	Perforated strap angle α for cavity b ① [mm]								Hole diameter installation part d [mm]	Spacing of hole e_1 [mm]	Edge distance a_r [mm]
		60	70	80	90	100	110	120	≥ 130			
5.0	6.75	-	-	25.0°	25.0°	25.0°	25.0°	25.0°	25.0°	Ø 11	24	100
8.0	10.80	-	-	25.0°	25.0°	25.0°	25.0°	25.0°	25.0°	Ø 13	28	130
11.5	15.53	-	-	-	-	25.0°	25.0°	25.0°	25.0°	Ø 17	37	150
16.0	21.60	-	-	-	-	-	25.0°	25.0°	25.0°	Ø 21	46	175
22.0	29.70	-	-	-	-	-	22.5°	22.5°	22.5°	Ø 21	46	210
34.0	45.90	-	-	-	-	-	-	-	22.5°	Ø 25	55	260

① For more information on perforated straps, see page 15

HALFEN CONCRETE FAÇADE ANCHOR SYSTEMS

Basic Static Calculations

Calculation of the anchor forces and selection of required fittings to support a façade slab

When fixing a suspended façade slab, two façade anchors are needed as support for the vertical forces (dead weight) and four horizontal anchors (generally two DS Spacer bolts at the upper and two at the lower edge) are needed to ensure the wall space. With stacked suspended façade slabs the lower spacer bolts are replaced with HFV Dowels.

Depending on slab geometry and expected wind loads, additional anchorage for wind suction may be required for the horizontal anchor (e.g. compression-bolt or restraint anchor).



No more than two façade anchors allowed per precast slab

Actions:

G = Vertical weight from proportional dead weight of the slab

With symmetrical suspension, G per anchor is = 1/2 dead weight of the slab

wd = Wind pressure load per horizontal anchor

ws = Wind suction load per horizontal anchor

Global safety factor of 1.2 against lift-off (according to expert reports)

Partial safety factor, acting loads:

γ_G = 1.35 constant influence (dead load)

γ_Q = 1.50 variable influence (wind load)

Anchor loads:

V_d = Vertical load in the anchor = $G \times \gamma_G$

H_d = Horizontal load in the anchor = $V_d \times \tan \alpha$

R_d = Resulting diagonal load in the anchor = $\sqrt{(V_d^2 + H_d^2)}$

Spacer bolt loads (horizontal):

Do_d = at top (from $Do_{g,d} + Do_{w,d}$)

Du_d = at base (from $Du_{g,d} + Du_{w,d}$)

$Do_{g,d}$ = at top from dead weight $\times \gamma_G$

max $Do_{w,d}$ = at top from wind ($wd \times \gamma_Q$)

min $Do_{w,d}$ = at top from wind ($ws \times \gamma_Q$)

$Du_{g,d}$ = at base from dead weight $\times \gamma_G$

max $Du_{w,d}$ = at base from wind ($wd \times \gamma_Q$)

min $Du_{w,d}$ = at base from wind ($ws \times \gamma_Q$)

Condition:

If min $Do_d < 0$
If min $Du_d < 0$ } Suction restraint necessary (e.g. LD / LD-A Adjustable restraint)

Calculation:

$\Sigma M_A \rightarrow Du_{g,d} = (H_d \times h_2 + V_d \times e) / h_1$

max $Du_d = Du_{g,d} + \max Du_{w,d}$

min $Du_d = Du_{g,d} - \min Du_{w,d}$

$\Sigma H \rightarrow Do_{g,d} = H_d - Du_{g,d}$

max $Do_d = Do_{g,d} + \max Do_{w,d}$

min $Do_d = Do_{g,d} - \min Do_{w,d}$

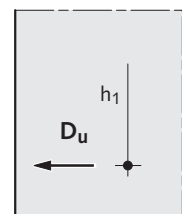
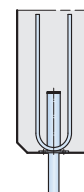
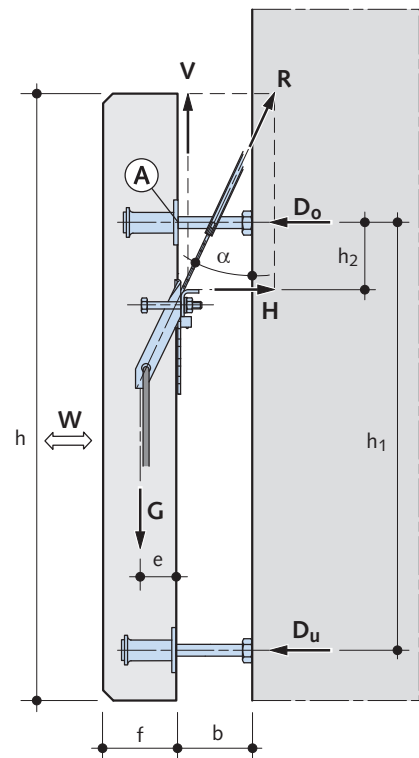

α = Angle of inclination
(see tables on page 7 to 11)

HALFEN CONCRETE FAÇADE ANCHOR SYSTEMS

Perforated Straps for HALFEN FPA-3 Façade Panel Anchors

Perforated straps for FPA-3 Façade panel anchors

FPA-3

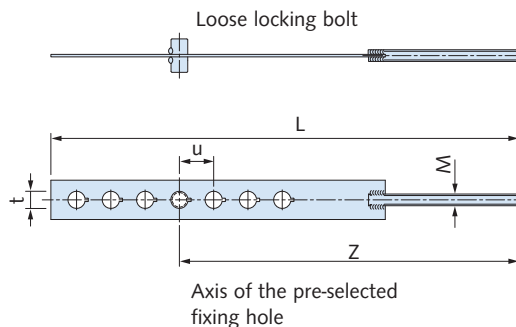
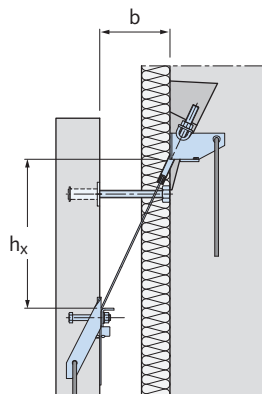

Dimension table perforated straps for FPA-3

Load group	5.0		8.0		11.5		16.0		22.0		34.0		46.0		56.0									
Thread	M8		M10		M12		M14		M16		M20		M27		M30									
Wrench size	13		17		19		22		24		30		41		46									
t [mm]	11		13		17		21		21		25		28		31									
u [mm]	21		25		33		41		41		50		56		62									
Cavity b [mm]	hx	L		hx	L		hx	L		hx	L		hx	L		hx	L							
		⊙	Z		⊙	Z		⊙	Z		⊙	Z		⊙	Z		⊙	Z						
60	130		251	140		284	130		316	135		320	170		378	170		393	220		458	230		500
70	150		293	160		309	150		316	160		361	195		378	195		443	245		514	260		562
80	175	435 (12/M)	314	180	453 (10/M)	334	175	506 (8/M)	349	180	515 (6/M)	361	220	614 (8/M)	419	220	630 (6/M)	443	275	724 (6/M)	514	285	794 (6/M)	562
90	195		335	205		359	195		382	200		402	245		460	245		493	300		570	315		624
100	215		356	225		384	215		382	220		402	265		460	270		493	330		626	340		624
110	235		377	245		409	240		415	245		443	290		501	295		543	355		626	370		686
120	260		398	265		434	260		448	265		484	315		542	315		543	385		682	395		686
130	280		419	290		459	280		481	285		484	340		542	340		593	410		682	425		748
140	300		440	310		459	300		481	310		525	365		583	365		593	440		738	450		748
150	325		482	330		484	325		514	330	679 (6/L)	525	390		624	390		643	465		738	480		748
160	345		503	355	653 (10/L)	509	345	704 (8/L)	547	350		566	410		624	415	830 (6/L)	643	495	948 (6/L)	794	505	1042 (6/L)	810
170	365	645 (12/L)	524	375		534	365		547	370		566	435		665	435		693	520		794	535		872
180	385		545	395		559	390		580	395		607	460	860 (8/L)	665	460		693	550		850	560		872
190	410		566	415		584	410		613	415		648	485		706	485		743	575		850	590		872
200	430		587	440		609	430		646	435		648	510		747	510		793	605		906	615		934
210	450		608	460		634	450		646	460		689	535		747	535		793	630		906	645		934
220	475		650	505		659	475		679	480	843 (6/XL)	689	550		788	560		843	660		962	670		996
230	490		671	505		684	495		712	500		730	580		829	580		843	685		962	700		996
240	515		692	525	853 (10/XL)	709	515		712	520		730	605		829	605	1030 (6/XL)	893	715	1172 (6/XL)	1018	725		1058
250	535		713	545		734	540		745	545		771	630		870	630		893	740		1018	755		1058
260	560	855 (12/XL)	734	565		759	560	902 (8/XL)	778	565		812	655		911	655		943	770		1074	780	1290 (6/XL)	1120
270	580		755	590		784	580		811				675		911	680		943	795		1074	810		1120
280	600		776	610		809	600		811				700	1106 (8/XL)	952	705		993	825		1130	835		1182
290	625		797	630		834	625		844				725		952							865		1182
300	645		818			845			877				750		993							890		1244
310													775											
320													800											
330													820											

Perforated straps for larger cavities on request ⊙ values in brackets → number of holes / type of perforated strap (M/L/XL)

HALFEN CONCRETE FAÇADE ANCHOR SYSTEMS

Perforated Straps for HALFEN FPA-5, FPA-5Z, FPA-5A and FPA-5AZ Façade Panel Anchors

Perforated straps for FPA-5, FPA-5Z, FPA-5A and FPA-5AZ Façade panel anchors

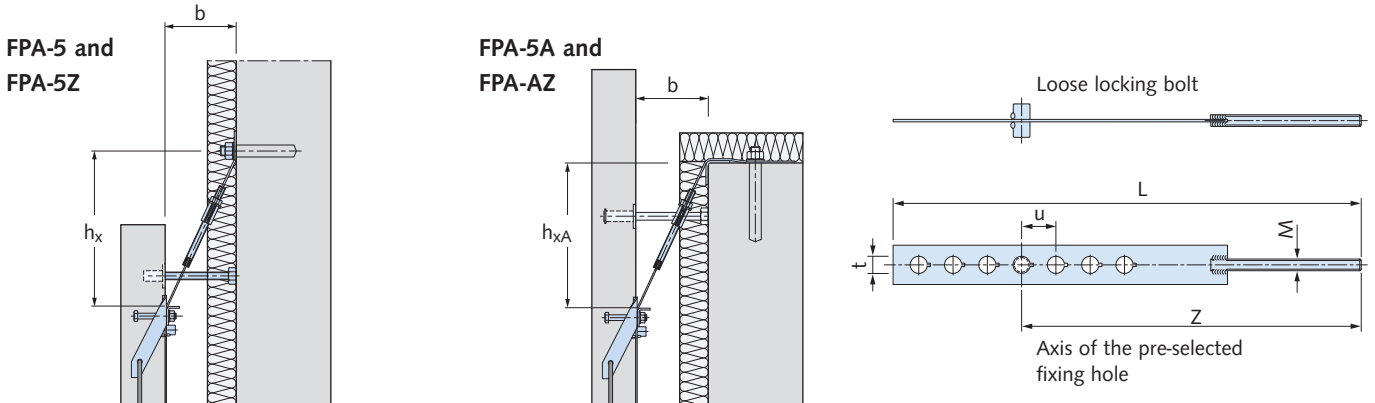

Dimension table: perforated straps for FPA-5, FPA-5Z, FPA-5A and FPA-5AZ

Load group	5.0		8.0		11.5		16.0		22.0		34.0		46.0		56.0			
Thread	M8		M10		M12		M14		M16		M20		M27		M30			
SW, t, u	Dimensions t, u and wrench size see "dimension table perforated straps for FPA-3" (page 13)																	
Cavity b [mm]	hx ②	hxA ③	L ①	Z	hx ②	hxA ③	L ①	Z	hx ②	hxA ③	L ①	Z	hx ②	hxA ③	L ①	Z		
60	195	180		188	200	180		184	225	205		217	255	235		238	275	250
70	195	180	246	188	195	180		184	225	205		217	255	230		238	280	255
80	190	175	(4/S)	188	190	175		184	220	200		217	250	230		238	270	250
90	210	195		209	210	195		209	215	195		217	240	220		238	275	250
100	230	215		230	235	215		234	235	215		250	240	215		238	265	245
110	255	240		251	255	240		259	260	240		250	260	240		279	290	270
120	275	260		272	275	260		284	280	260		283	280	260		279	315	290
130	295	280		293	295	280		309	300	280		316	305	280		320	340	315
140	315	305	435 (12/M)	314	320	305		334	320	305		349	325	305		320	365	340
150	340	325		356	340	325		359	345	325		349	345	325		361	390	365
160	360	345		377	360	345		359	365	345		382	365	345		361	410	390
170	380	365		398	385	365		409	385	365		415	390	365		402	435	415
180	405	390		419	405	390		409	410	390		415	410	390		443	460	435
190	425	410		440	425	410		434	430	410		448	430	410		443	485	460
200	445	430		461	445	430		459	450	430		481	455	430		484	510	485
210	470	455		482	470	455		484	470	455		514	475	455		484	535	510
220	490	475	645 (12/L)	524	490	475		509	495	475		514	495	475		525	555	535
230	510	495		545	510	495		534	515	495		547	515	495		525	580	560
240	530	515		566	535	515		559	535	515		580	540	515		566	605	580
250	555	540		587	555	540		584	560	540		580	560	540		607	630	605
260	575	560		608	575	560		609	580	560		613	580	560		607	655	630
270	595	580		629	595	580		634	600	580		646	605	580		648	680	655
280	620	605		650	620	605		659	620	605		679	625	605		648	700	680
290	640	625		671	640	625		684	645	625		679	645	625		689	725	705
300	660	645		692	660	645		709	665	645		712	665	645		730	750	725
310	680	665		734	685	665		734	685	665		745	690	665		730	775	750
320	705	690	855 (12/XL)	755	705	690		759	710	690		771	800	775		771	800	775
330	725	710		776	725	710		784	730	710		778	730	710		771	825	800
340	745	730		797	745	730		784	750	730		811	755	730		812	845	825
350	770	755		818	770	755		834	770	755		844				870	845	
360								795	775			844				895	870	
370								795				877				920	895	
380																945	920	
390																970	945	
400																990	970	
410																1015	990	
420																		

Perforated straps for larger wall cavities on request ① Values in brackets → number of holes/type of perforated strap (S/M/L/XL) ② hx for FPA-5/5Z ③ hxA for FPA-5A/5AZ

HALFEN CONCRETE FAÇADE ANCHOR SYSTEMS

Perforated Straps for HALFEN FPA-5S Façade Panel Anchors

Perforated straps for FPA-5S Façade panel anchors

FPA-5S

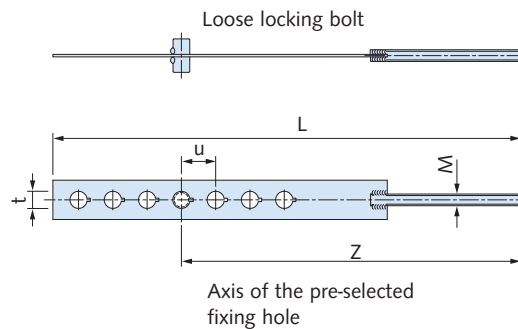
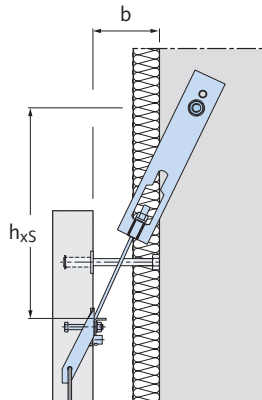

Dimension table; perforated straps for FPA-5S

Load group	5.0			8.0			11.5			16.0			22.0			34.0		
Thread	M8			M10			M12			M14			M16			M20		
Wrench size	13			17			19			22			24			30		
t [mm]	11			13			17			21			21			25		
u [mm]	21			25			33			41			41			50		
Cavity b [mm]	h _{xs}	L Ⓢ	Z	h _{xs}	L Ⓢ	Z	h _{xs}	L Ⓢ	Z	h _{xs}	L Ⓢ	Z	h _{xs}	L Ⓢ	Z	h _{xs}	L Ⓢ	Z
60	-		-	-		-	-		-	-		-	-		-	-		-
70	-	246 (4/S)	-	-		-	-		-	-		-	-		-	-		-
80	390		188	455	278 (4/S)	184	-	341 (4/S)	-	-		-	-		-	-		-
90	410		209	475		209	-		-	-		-	-		-	-		-
100	430		230	495		234	535		250	-	392 (4/S)	-	-	409 (4/S)	-	-	480 (4/S)	-
110	455		251	520		259	560		250	615		279	775		296	-		-
120	475		272	540		284	580		283	635		279	795		296	-		-
130	495		293	560		309	600		316	655		320	820		337	945		343
140	520	12/M	314	585	453 (10/M)	334	625		349	680		320	845		378	970		393
150	540		356	605		359	645		349	700		361	870		378	995		393
160	560		377	625		359	665		382	720		361	895		419	1020		443
170	580		398	645		409	685		415	740	515 (6/M)	402	920	614 (8/M)	460	1045		443
180	605		419	670		409	710		415	765		443	940		460	1065	630 (6/M)	493
190	625		440	690		434	730		448	785		443	965		501	1090		493
200	645		461	710		459	750		481	805		484	990		542	1115		543
210	670		482	735		484	775		514	830		484	1015		542	1140		543
220	690	12/L	524	755	653 (10/L)	509	795		514	850		525	1040		583	1165		593
230	710		545	775		534	815		547	870	679 (6/L)	525	1065		583	1190		593
240	730		566	795		559	835		580	890		566	1085		624	1210		643
250	755		587	820		584	860		580	915		607	1110		665	1235	830 (6/L)	643
260	775		608	840		609	880		613	935		607	1135		665	1260		693
270	795		629	860		634	900		646	955		648	1160		706	1285		693
280	820		650	885		659	925		679	980		648	1185		747	1310		743
290	840		671	905		684	945		679	1000		689	1210		747	1335		793
300	860		692	925		709	965		712	1020	843 (6/XL)	730	1230		788	1355		793
310	880	12/XL	734	945	853 (10/XL)	734	985		745	1040		730	1255		829	1380		843
320	905		755	970		759	1010		745	1065		771	1280		829	1405	1030 (6/XL)	843
330	925		776	990		784	1030		778	1085		771	1305		870	1430		893
340	945		797	1010		784	1050		811	1105		812	1330		870	1455		893
350	970		818	1035		834	1075		844				1350		911	1475		943
360									1095				1375	1106 (8/XL)		952		
370									1115				1400			952		
380													1425			993		
390													1450			1034		
400													1475			1034		
410													1495			1075		

Perforated straps for larger wall cavities on request Ⓢ Values in brackets → number of holes/type of perforated strap (S/M/L/XL)

HALFEN CONCRETE FAÇADE ANCHOR SYSTEMS

Installation of the Façade Panel Anchor Connection FPA-3 and FPA-5

Installing the FPA-3/5-E

1.1 The FPA-3/5-E Cast-in panel connection, consisting of shaped bracket, angled bracket and polystyrene recess former is delivered pre-assembled.

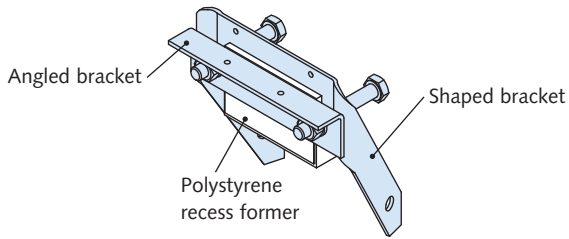

1.2 Insert reinforcement stirrups into the provided holes.

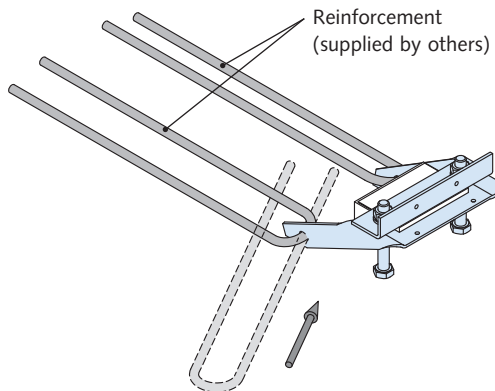

1.3 Secure to the formwork with nails. Nail holes are provided on the shaped bracket and on the angled bracket.

Note: The auxiliary construction must be exactly flush with the highlighted surface ①

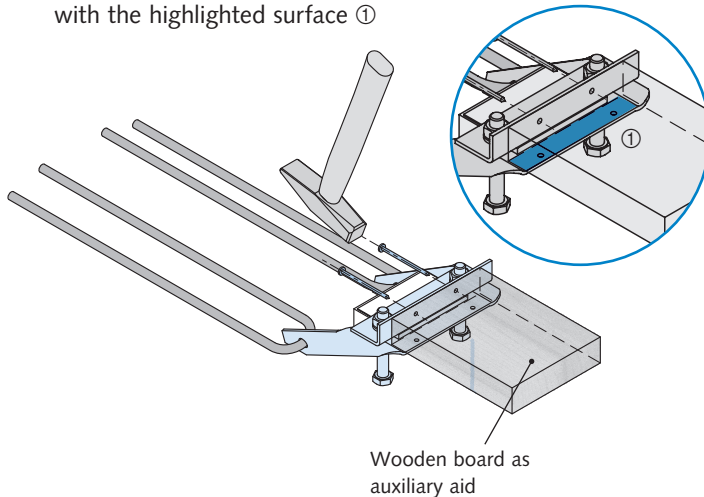

Installing the FPA-3-R

2.1 Place the recess former onto the support arm.

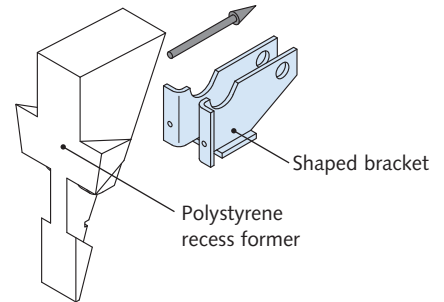

2.2 Insert a reinforcement stirrup through the rear holes in the support arm.

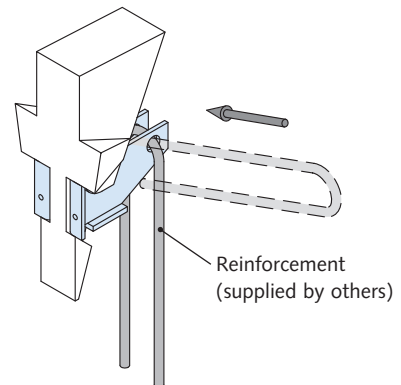

2.3 Attach the cast-in support to the formwork with 2 nails (secure with additional reinforcement if necessary).

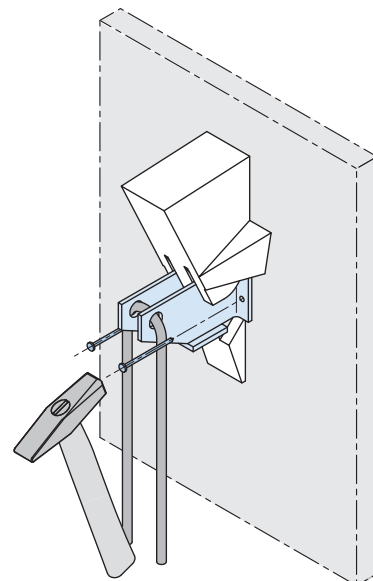

HALFEN CONCRETE FAÇADE ANCHOR SYSTEMS

Installation of the Façade Panel Anchors FPA-3 and FPA-5

Installing the perforated strap

1.1 Remove the polystyrene recess former. Any polystyrene still in the space between the shaped bracket and angled bracket can be pushed out with the perforated strap.

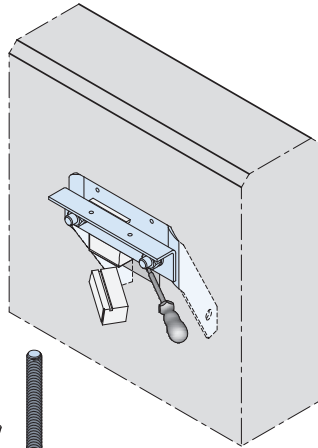

1.2 Insert the perforated strap between the shaped bracket and the angled bracket.

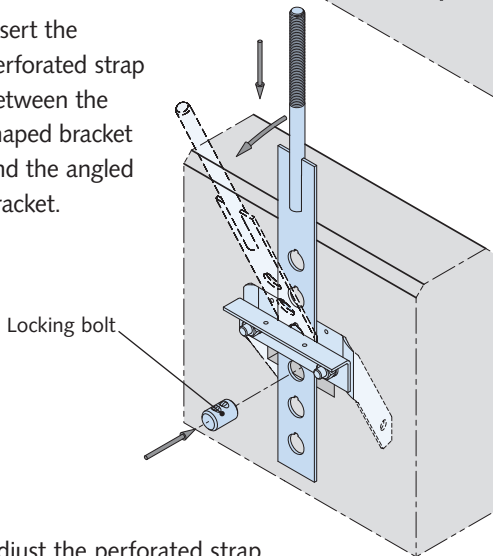

1.3 Adjust the perforated strap roughly to the required length. Secure the perforated strap using the locking bolt (turn the bolt 180°) and bend over the angled bracket.

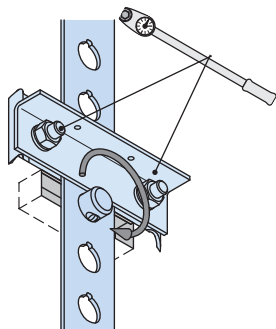

1.4 Tighten the nuts to the torque listed in the table below.

Recommended torque for façade panel cast-in parts			
Load group	Torque [Nm]	Spanner size	Colour code
5.0	5	13	yellow
8.0	5	13	red
11.5	10	17	blue
16.0	15	19	green
22.0	15	19	brown
34.0	30	24	black
46.0	60	30	orange
56.0	60	30	white

Assembly to the pre-cast panel

2.1 Mount the slotted strap onto the threaded rod of the perforated strap using a washer and nut.

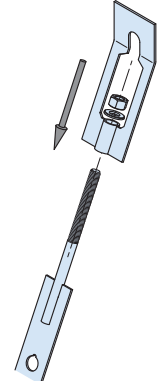

2.2 Fix the upper part to the pre-drilled dowel or channel.

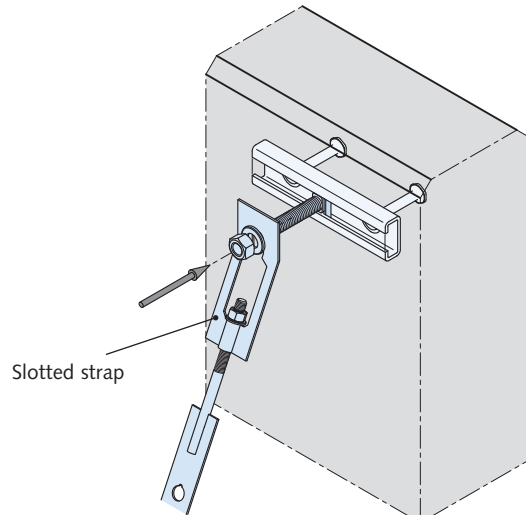

3.1 Fix the locating pin and washer to the threaded rod of the perforated strap, secure with the nut and suspend from the cast-in element.

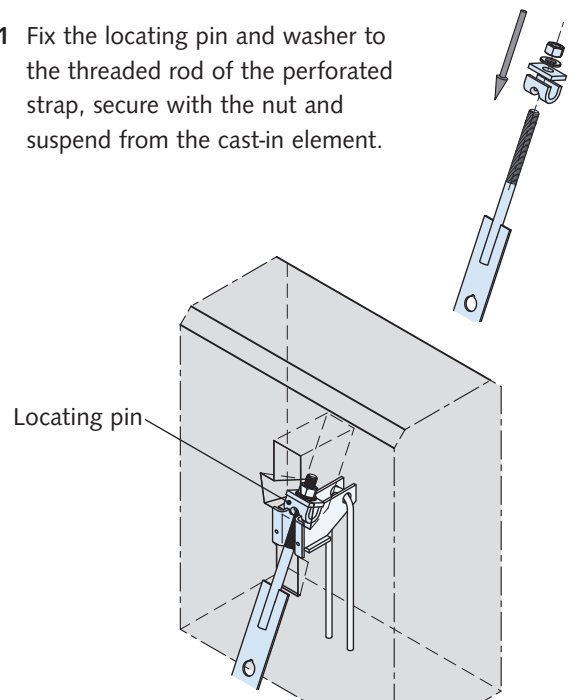

HALFEN CONCRETE FAÇADE ANCHOR SYSTEMS

HALFEN WPA Top Fixing Dowel

WPA-A/-B Top fixing dowel

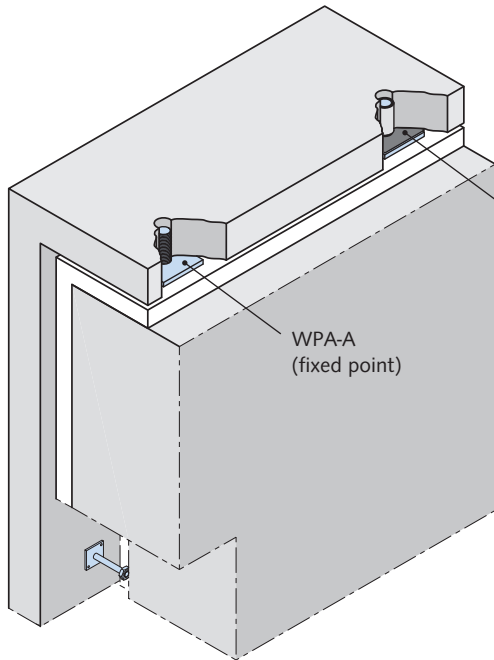

Type WPA-B
(with plastic sleeve and elastomer support on the plate to allow for thermal expansion)

WPA-A
(fixed point)

The top fixing dowel allows height adjustment of ± 20 mm.

Load group 5.0 to 16.0:

$b = 20$ mm: $+ 20$ mm; $- 5$ mm

$b = 30$ mm: $+ 20$ mm; $- 15$ mm

$b \geq 40$ mm: ± 20 mm

Load group 22.0 to 34.0:

$b = 30$ mm: $+ 20$ mm; $- 10$ mm

$b \geq 40$ mm: ± 20 mm

One dowel must be fitted with a plastic sleeve to allow for thermal expansion.

Ordering example: WPA - A - 11.5 - 60

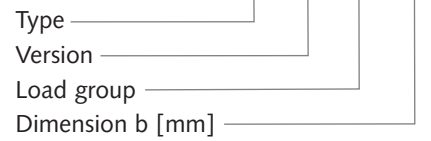

Approximate anchor dimensioning

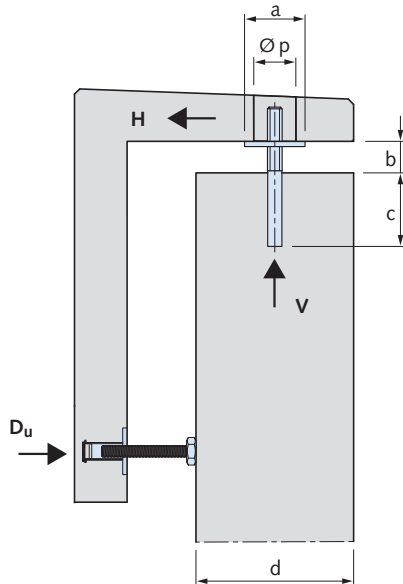

Individual certification:

Not necessary if H_{max} and V_{max} are complied with according to the table on page 19.

Dimensioning example:

assumed: $V_k = 10.0$ kN

$H_k = 2.0$ kN

$b = 8$ cm

Pre-selecting a load group

selected: Load group 11.5

$$N_d = 1.35 \times V_k \text{ [kN]}$$

$$= 1.35 \times 10.0 = 13.5 \text{ kN}$$

$$M_d = 1.4 \times H_k \times (b + \varnothing D) \text{ [kNcm]}$$

$$= 1.4 \times 2.0 \times (8.0 + 2.9) = 30.52 \text{ kNcm}$$

$$\rightarrow N_d / (\kappa \times N_{Rd}) + M_d / M_{Rd} + temp \leq 1.0$$

$$13.5 / 94 + 30.52 / 57.2 + 0.26$$

$$= 0.937 < 1.00 \checkmark$$

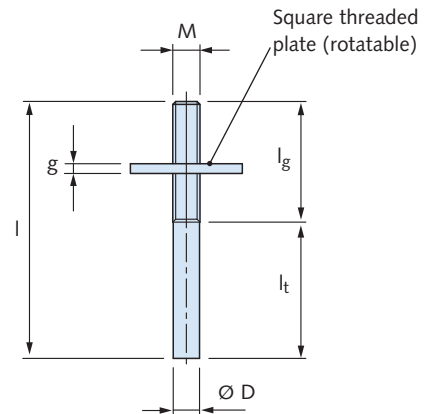

HALFEN CONCRETE FAÇADE ANCHOR SYSTEMS

HALFEN WPA Top Fixing Dowel

Dimension table WPA Top fixing dowel													
Load group	N _{d,max} [kN]	Distance ① b [cm]	κ × N _{Rd} [kN]	M _{y,Rd} [kNcm]	temp [-]	H _{k,max} [kN]	d _{min} [cm]	Thread M	Ø D × L [mm]	l _g + l _t [mm]	a × g [mm]	Ø p [mm]	min c [mm]
5.0	6.75	2.0 ②	64	24.9	0.12	2.20	15	M24 × 1.5	22 × 295	135 + 160	110 × 10	60	160
		4.0	58		0.16	1.55	15						
		6.0	53		0.20	1.15	15						
		8.0	49		0.24	0.88	15						
8.0	10.80	2.0 ②	99	46.1	0.10	3.90	20	M28 × 1.5	27 × 295	135 + 160	115 × 10	70	160
		4.0	92		0.13	2.90	18						
		6.0	86		0.16	2.20	16						
		8.0	80		0.19	1.75	15						
11.5	15.53	2.0 ②	115	57.2	0.14	4.20	20	M30 × 1.5	29 × 330	140 + 190	120 × 12	70	190
		4.0	108		0.18	3.10	18						
		6.0	101		0.22	2.30	16						
		8.0	94		0.26	1.75	15						
16.0	21.60	2.0 ②	161	92.1	0.13	6.50	26	M35 × 1.5	34 × 335	145 + 190	125 × 12	70	190
		4.0	153		0.16	4.80	22						
		6.0	144		0.20	3.70	20						
		8.0	136		0.23	2.90	18						
22.0	29.70	4.0	194	128.5	0.17	6.30	24	M39 × 1.5	40 × 365	145 + 220	140 × 15	80	220
		6.0	184		0.20	4.85	22						
		8.0	175		0.24	3.85	20						
34.0	45.90	4.0	265	199.6	0.18	8.80	30	M45 × 1.5	44 × 395	145 + 250	140 × 15	80	250
		6.0	254		0.21	6.80	25						
		8.0	243		0.25	5.40	23						

① Values include a vertical adjustment range of ± 20 mm

② Vertical adjustment range can only be fully utilized in the upward direction

Assembly and installation instructions for top fixing dowels

1. A recess (corrugated sheathing tube) is provided in the precast concrete element for the threaded dowel, the dowel is grouted in, perpendicularly, using concrete / mortar with a strength class of at least C30/37 as defined in DIN EN 1992-1-1. Alternatively, the dowel may also be cast directly into the concrete ensuring it remains completely perpendicular.
2. A recess is provided in the precast corner panel to grout the dowel after final alignment.

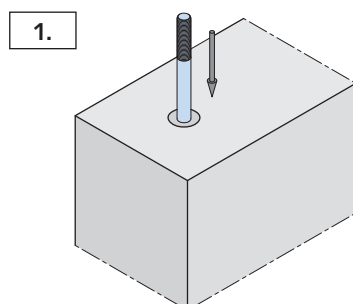

3. Remove any protective cover from the threaded dowel and ensure the thread is clean; the threaded plate is screwed on and pre-adjusted.
4. The precast corner panel is adjusted. Horizontal alignment is possible within the limits of the (grout)

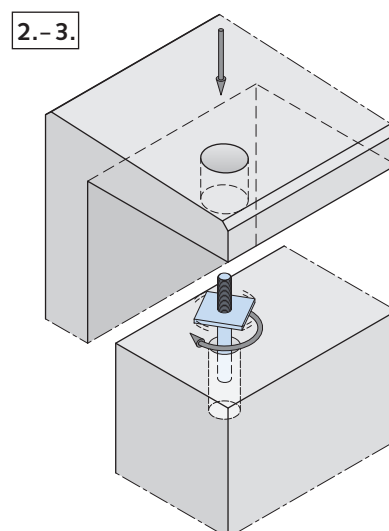

- recess; for vertical alignment the threaded plate is turned up or down, respectively.
5. After the panel is aligned the recess is filled (strength class ≥ C20/25 as defined in DIN EN 1992-1-1). Secure the position of the panel until the concrete / mortar has hardened.

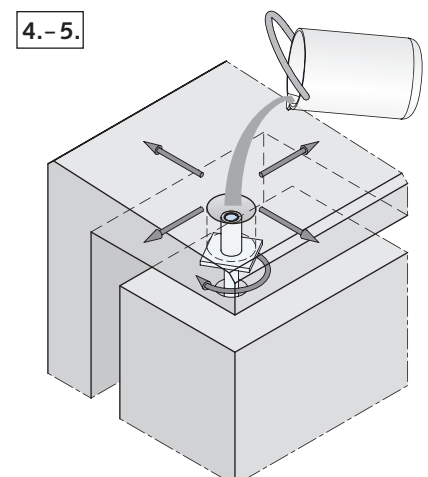

HALFEN CONCRETE FAÇADE ANCHOR SYSTEMS

HALFEN BRA-L4 Parapet Corbel

BRA-N L4, Parapet corbel standard version (required installation accessories: BRA-M1)

Type; Standard bracket type without height adjustment bolt.
Sizes: BRA-1 to BRA-8.

Larger special brackets are possible. Limited height adjustment is possible. Additional shims are required; these are placed under the bracket's front point of load. HALFEN Cast-in channels or approved dowels are used to connect the brackets.

Application example for the BRA-N Bracket type is to support balcony parapets. The bracket may be recessed into the top of the floor slab. To ensure even load distribution only two brackets are allowed to be used per panel. If more than two anchor are used it is absolutely essential to use the adjustable BRA-NJ Bracket type.

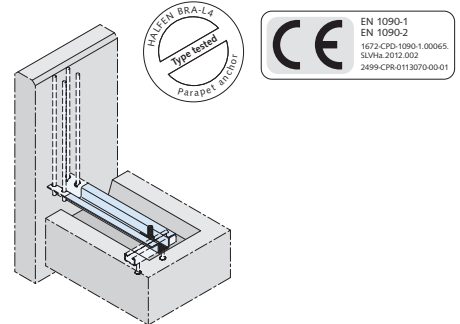

BRA-A L4, Parapet corbel suspended version (required installation accessories: BRA-M1)

Type; Standard bracket suspension type without height adjustment bolt.
Sizes: BRA-1 to BRA-8.

Larger special brackets are possible. Limited height adjustment is possible. Additional shims are required; these are placed under the bracket's front point of load. HALFEN Cast-in channels or approved dowels are used to

connect the brackets. Application example for the BRA-A Bracket type is to support suspended roof-parapets elements. To ensure even load distribution only two brackets are allowed to be used per panel. If more than two anchor are used it is absolutely essential to use the adjustable BRA-NJ Bracket type.

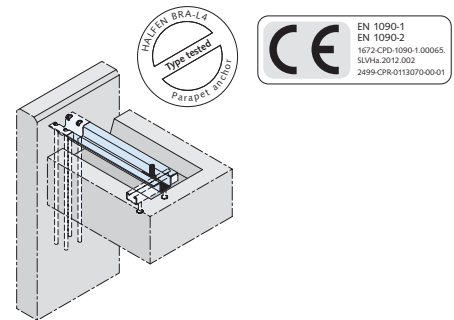

BRA-NJ L4, Parapet corbel standard version, adjustable (required installation accessories: BRA-M1 and BRA-M2)

Type; Standard bracket type with height adjustment bolt.
Sizes: BRA-1 to BRA-8.

Larger special brackets are possible. Adjustment accessory BRA-M2 is required for exact height adjustment. HALFEN Cast-in channels or approved dowels are used to connect the brackets.

If feasible, only two brackets should be used for each panel element. In exceptional load situations three anchors can be installed; however, appropriate measures are required to ensure the load is evenly distributed.

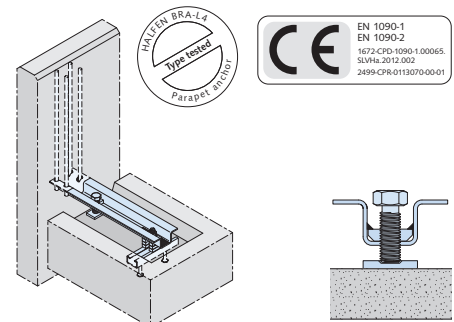

BRA-AJ L4, Parapet corbel suspended version, adjustable (required installation accessories: BRA-M1 and BRA-M2)

Type; Standard bracket suspension type with height adjustment bolt.
Sizes: BRA-1 to BRA-8.

Larger special brackets are possible. Adjustment accessory BRA-M2 is required for exact height adjustment. HALFEN Cast-in channels or approved dowels are used to connect the brackets.

If possible, only two brackets should be used for each panel element. In exceptional load situations three anchors can be installed; however, appropriate measures are required to ensure the load is evenly distributed.

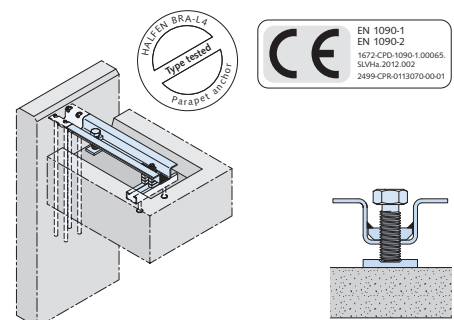

HALFEN CONCRETE FAÇADE ANCHOR SYSTEMS

HALFEN BRA-L4 Parapet Corbel: Product Overview

Article name and dimensions

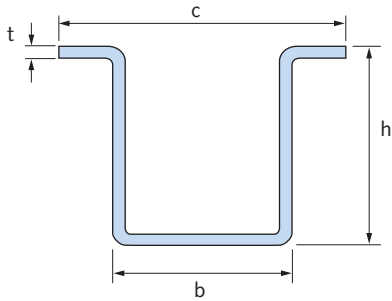

Order example:

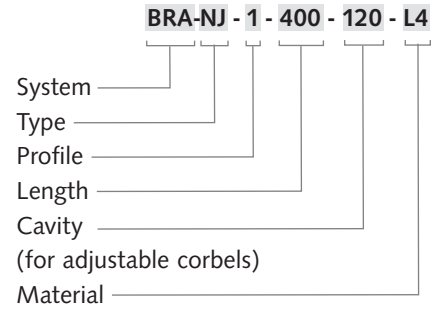

Dimension table BRA-L4 Parapet corbel

Profile	b [mm]	h [mm]	c [mm]	t [mm]
BRA 1	40	44	74	3
BRA 2	45	48	84	3
BRA 3	51	54	94	4
BRA 4	65	66	122	4
BRA 5	66	70	122	5
BRA 6	77	83	144	5
BRA 7	80	84	148	6
BRA 8	80	85	144	8

BRA Types:

- BRA - **A** → Suspended version (downward rebars)
- BRA - **AJ** → Suspended version adjustable (downward rebars)
- BRA - **N** → Standard-version (upward rebars)
- BRA - **NJ** → Standard-version adjustable (upward rebars)

BRA-L4 profile choice

BRA-N L4

Standard model without height adjustment bolt

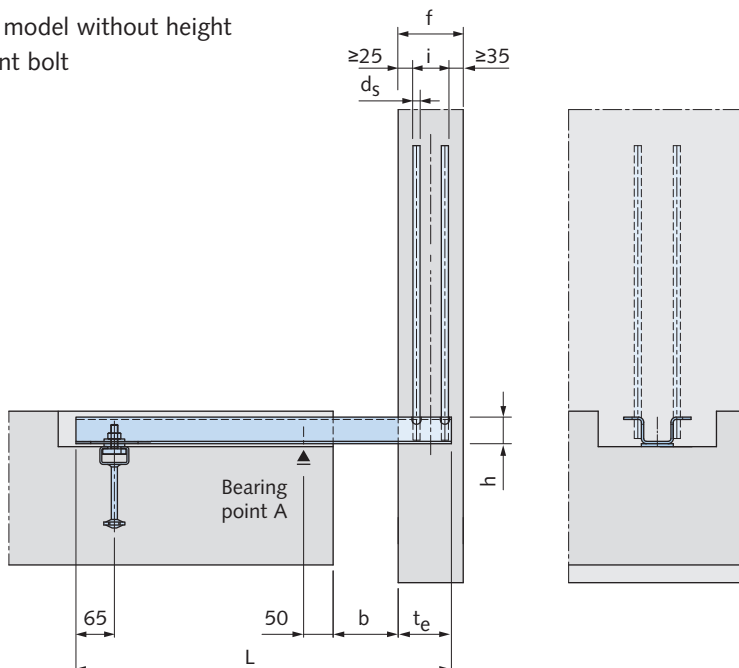

The required profile for the HALFEN Parapet anchor is selected by calculating the bending moment 'M_y' and the shear load (dead load) 'D' at bearing point 'A' (dead load, wind, live load etc.); the results are then checked and verified against the allowable values in the table on the next page.

A calculation program to determine BRA profiles and for verifiable static calculations is available for download at www.halfen.com.

HALFEN CONCRETE FAÇADE ANCHOR SYSTEMS

Dimensioning of HALFEN BRA-L4 Parapet Corbel

Dimensioning (see also → type test report)

1. $M_{i,d} = \gamma_G \cdot V \cdot a_1 + \gamma_Q \cdot \psi_0 \cdot W \cdot e_w + \gamma_Q \cdot \psi_0 \cdot H \cdot h_1 \leq M_{i,R,d}$
2. $M_{y,d} = M_{i,d} + \gamma_G \cdot G \cdot \left(\frac{f}{2} + b + 50\text{mm}\right) + \gamma_G \cdot V \cdot \left(\frac{f}{2} + b + 50\text{mm}\right) \leq [1 - (N_d/N_{pl,d})^{1,2}] M_{pl,d}$
3. $V_{z,d} = \gamma_G \cdot G + \gamma_G \cdot V \leq V_{z,R,d}$
4. $Z_d = \frac{M_{y,d}}{y} \leq Z_{R,d}$
5. $D_d = Z_d + V_{z,d} \leq D_{R,d}$
6. $D_d \geq 0$ (proof against uplift)
7. $N_d = \gamma_Q \cdot \psi_0 \cdot W + \gamma_Q \cdot \psi_0 \cdot H \leq N_{R,d}$

Interaction design:

$$\frac{M_{z,d}}{M_{pl,z,d}} + \left(\frac{N_d}{N_{pl,d}}\right)^{2,6} + \left[1 - \left(\frac{N_d}{N_{pl,d}}\right)^{2,6}\right] \cdot \frac{N_{pl,d}}{N_d} \cdot \left(\frac{M_{y,d}}{M_{pl,y,d}}\right)^{2,3} \leq 1$$

Vertical deflection: $f_z = \frac{M_{y,k} \cdot L_1 \cdot \left(L_2 + \frac{L_1}{2}\right)}{3 \cdot E \cdot I_y}$

with: $L_1 = \frac{f}{2} + e + 50\text{mm}; L_2 = L - t_e - 65\text{mm} + \frac{f}{2}$

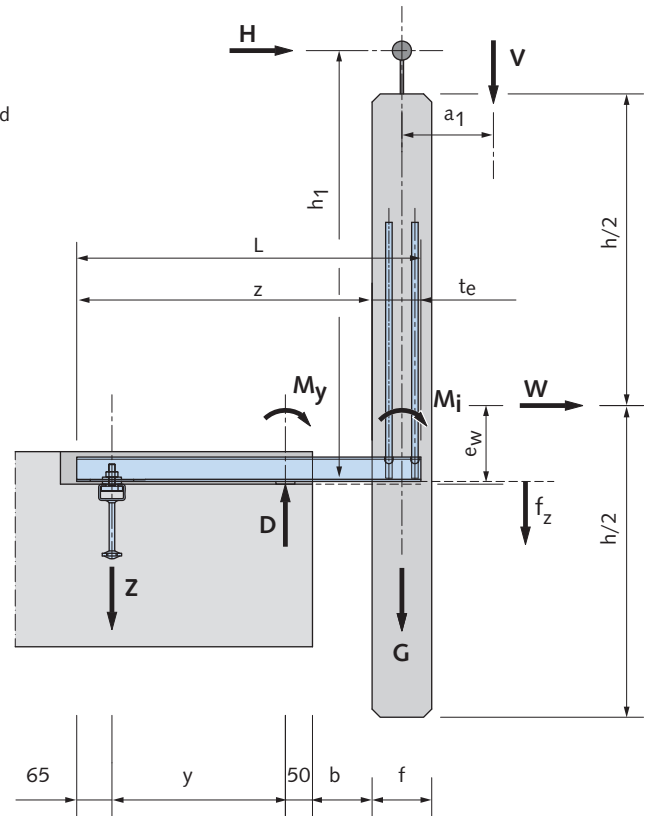

Actions, safety factors

Reactions:

- G = Dead weight
- V = Vertical load (e.g. flower planter)
- H = Horizontal load (hand-rail load)
- W = Wind load

Partial safety factor:

- $\gamma_G = 1,35$ (unfavourable load position)
- $\gamma_G = 1,0$ (favourable load position)
- $\gamma_Q = 1,50$ (unfavourable load position)
- $\gamma_Q = 0$ (favourable load position)
- $\psi_0 = 1,0$ (decisive action)
- $\psi_0 = 0,7$ (hand-rail load)
- $\psi_0 = 0,6$ (additional actions)



Please use our dimensioning software to select the correct type of anchor for static verification.

Load capacity, cross section values

	BRA 1	BRA 2	BRA 3	BRA 4	BRA 5	BRA 6	BRA 7	BRA 8
$M_{i,R,d}$ [kNcm]	190	204	374	616	750	1,032	1,294	1,730
$M_{pl,y,d}$ [kNcm]	270	335	558	857	1,137	1,630	1,986	2,439
$M_{pl,z,d}$ [kNcm]	246	313	531	849	1,082	1,524	1,905	2,455
$V_{z,R,d}$ [kN]	19.4	21.3	32.1	39.0	51.2	61.4	73.7	97.0
$Z_{R,d}$ [kN]	18.9	18.9	23.6	23.6	37.4	37.4	52.5	93.4
$D_{R,d}$ [kN]	38.7	38.7	45.3	45.3	68.0	68.0	79.3	79.3
$N_{R,d}$ [kN]	10.0	17.0	17.0	17.0	26.0	26.0	26.0	26.0
$N_{pl,d}$ [kN]	182	204	303	379	484	579	702	903
I_y [cm ⁴]	11.78	16.12	30.31	56.88	78.81	135.39	165.45	204.04

Anchoring at tie bearing

	BRA 1	BRA 2	BRA 3	BRA 4	BRA 5	BRA 6	BRA 7	BRA 8
diam. of the anchoring element	M12	M16	M16	M16	M20	M20	M20	M20
Minimum tightening torque [Nm]	25	60	60	60	120	120	120	120
Recommended HALFEN Cast-in channel HTA-CE ①	40/25	49/30	49/30	49/30	54/33	54/33	54/33	54/33

① Separate proof of the anchorage taking the respective boundary conditions into account must be provided

HALFEN CONCRETE FAÇADE ANCHOR SYSTEMS

Installation of HALFEN BRA-L4 Parapet Corbel

Casting into the precast panel

The bracket should be installed in the corbel panel ensuring the rear reinforcement bars have a minimum of 25 mm concrete cover to the inner facing. This subsequently affects the minimal required corbel panel thickness for the various BRA-profiles (see table). The height-placement of the brackets in the precast element depends on the installation plane in the slab pocket.

The bracket is often installed in a recess. The bottom of the recess then becomes the installation plane; otherwise the upper surface of the slab is the installation plane.

The bottom edge of the BRA-profile should be positioned at Δh above the installation plane:

$$\Delta h = 5-10 \text{ mm (for BRA-A / BRA-N)}$$

$$\Delta h = 15-25 \text{ mm (for BRA-AJ / BRA-NJ)}$$

Ensure sufficient concrete cover for the rebar welded to the anchor bracket at the bottom and top edge of the parapet.

In accordance with EC 2, if the rebars are too long these may be shortened by bending.

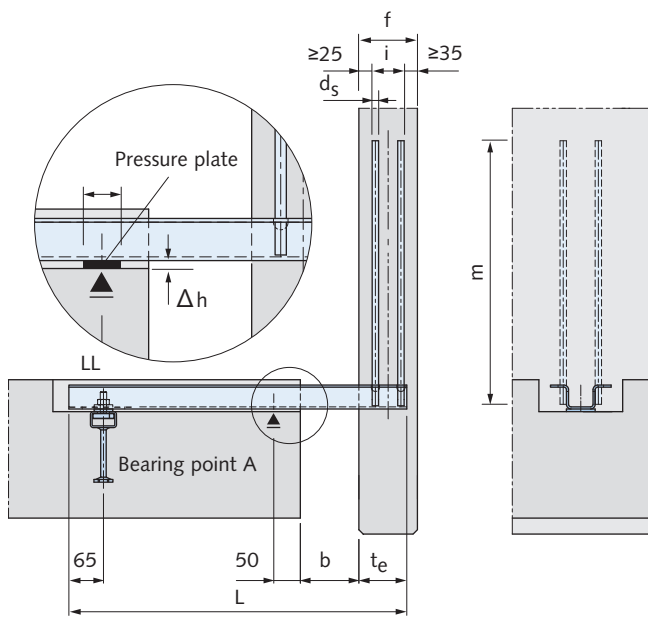

Type-N Standard model without height adjustment bolt

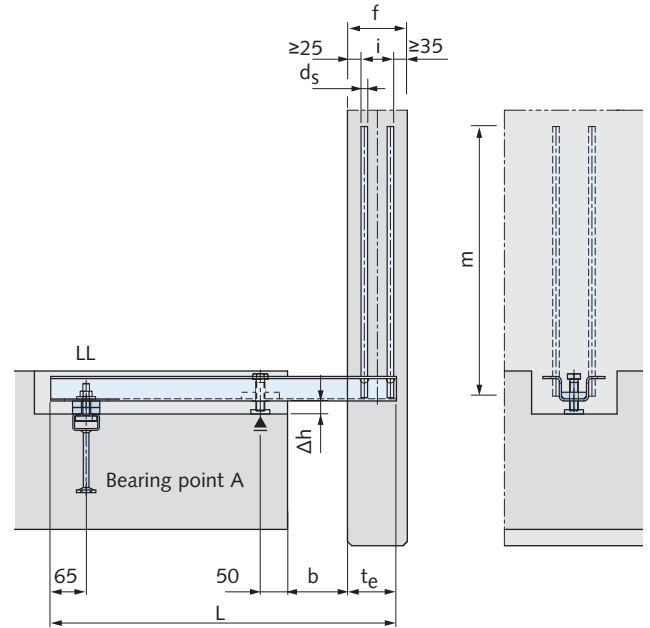

Type-NJ Standard model with height adjustment bolt

Designs of the BRA-L4 Parapet corbel [mm]

	Standard length recommended profile length L for cavity b ^①			Adjustment slot LL	Embedded depth ^② t _e	Panel thickness ^② min f	Bar d _s	Spacing i	height m	Minimum pressure plate dimensions a
	0-40 mm	50-100 mm	110-140 mm							
BRA 1	400	450	500	17 × 80	70	100	Ø 10	40	350	40
BRA 2	450	500	550	19 × 80	72	100	Ø 10	40	400	40
BRA 3	500	550	600	19 × 80	82	110	Ø 12	50	440	40
BRA 4	550	600	650	21 × 80	92	120	Ø 14	60	510	60
BRA 5	550	600	650	24 × 80	102	130	Ø 14	70	510	60
BRA 6	600	650	700	24 × 80	108	135	Ø 16	75	600	60
BRA 7	650	700	750	24 × 80	123	150	Ø 16	90	600	70
BRA 8	700	750	800	24 × 80	125	150	Ø 20	90	700	70

Material: Stainless steel L4 Lean Duplex (Omega profile), B500A, B500B (anchoring reinforcement). Stainless steel reinforcement on request.

① Other cavities and profile lengths are possible; use increments of 10 mm to specify other preferred lengths e.g. 40 mm

② Values apply for c_{nom,i} = 25 mm; c_{nom,a} = 35 mm

HALFEN CONCRETE FAÇADE ANCHOR SYSTEMS

Parapet Corbel Installation

Connection to the floor slab

Bracket anchors are normally connected to slabs using approved fixing products; generally HALFEN Cast-in channels and assembly accessories (order separately). Galvanized accessories will be sufficiently protected if the

brackets are installed in slab recesses, which are subsequently filled. For fittings that are not grouted or remain visible we recommend using stainless steel A4 installation brackets. Recommendations for anchoring elements

can be found in the table on page 22. We recommend designing the recesses with the dimensions as provided in the table below.

Recess dimensions [mm]

Type	Colour code	Recess width B	Recess height	
			For type -A and type -N	For type -AJ and type -NJ
BRA 1	yellow	200	70	80
BRA 2	red	200	70	80
BRA 3	blue	200	80	90
BRA 4	green	225	90	100
BRA 5	brown	225	90	100
BRA 6	black	250	110	120
BRA 7	orange	250	110	120
BRA 8	white	250	110	120

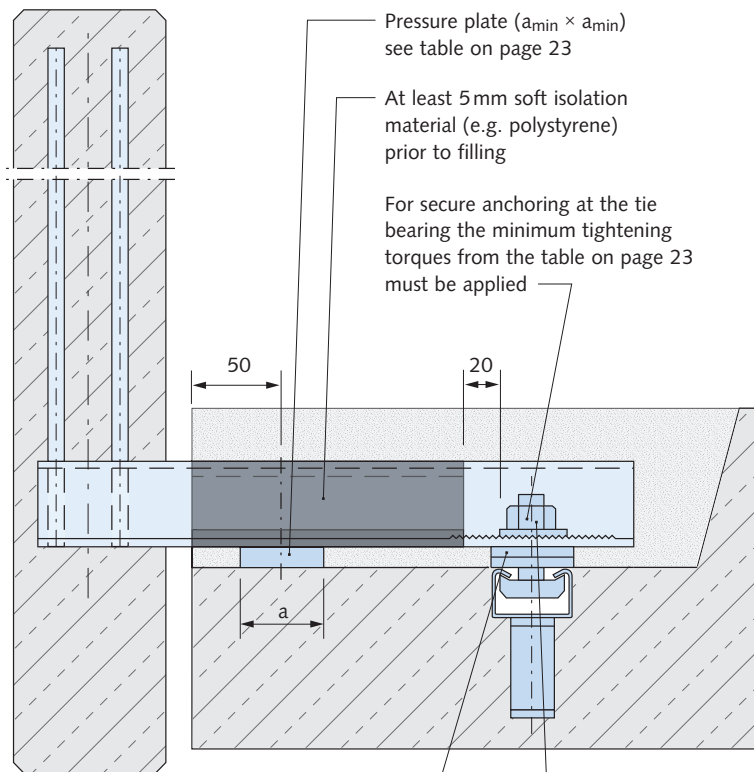

Recess installation of BRA-L4 with grouting

When installing the BRA-L4 in a recess, place an appropriate soft-insulation along the vertical sides of the anchor prior to filling with concrete. This avoids damage caused by temperature-fluctuations.

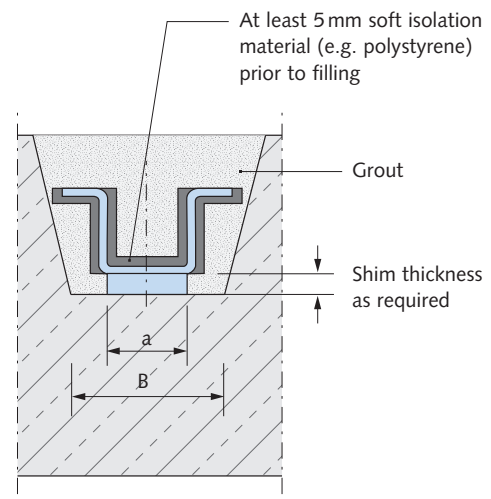

Material: Dowel (Channel bolt, nuts and washer) are galvanized, if the anchor is subsequently grouted; otherwise stainless steel 1.4571 or 1.4401

HALFEN CONCRETE FAÇADE ANCHOR SYSTEMS

Accessories for BRA-L4 Parapet Corbels

BRA-M1 Installation set

The HALFEN BRA-M1 Installation set is required to install the fixed parapet anchors type -N and type -A, as well as the adjustable anchors type -NJ

and type -AJ.
HALFEN BRA-M1 Installation set includes the serrated washer, one 3 mm shim and one 6 mm shim.

Fixing material must be selected and ordered separately i.e. HALFEN Cast-in channels including T-head bolts and dowels.

BRA-M1 Installation set

includes:

- one serrated plate
- 2 shims for height adjustment
thickness $t = 3\text{ mm}$ and $t = 6\text{ mm}$

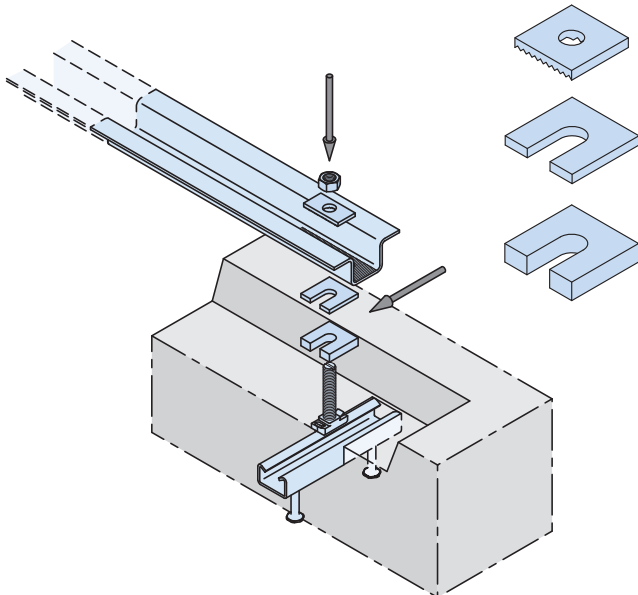

BRA-M1 required for all types of BRA Parapet brackets (order separately)

BRA-M1 Installation set

BRA Installation set	For bracket type	Maximum thread diameter	Hot-dip galvanized order no. 0250.150-	Stainless steel A4 order no. 0250.150-
BRA-M1 - 1	BRA - ... - 1	M12	00006	00001
BRA-M1 - 2	BRA - ... - 2	M16	00007	00002
BRA-M1 - 3	BRA - ... - 3	M16	00007	00002
BRA-M1 - 4	BRA - ... - 4	M16	00008	00003
BRA-M1 - 5	BRA - ... - 5	M20	00009	00004
BRA-M1 - 6	BRA - ... - 6	M20	00010	00005
BRA-M1 - 7	BRA - ... - 7	M20	00010	00005
BRA-M1 - 8	BRA - ... - 8	M20	00010	00005

HALFEN CONCRETE FAÇADE ANCHOR SYSTEMS

Accessories for BRA-L4 Parapet Corbels

BRA-M2 Installation set (for adjustable parapet brackets BRA-AJ and BRA-NJ)

The BRA-M2 Installation set is used to fix the height of the adjustable parapet brackets type -AJ and type -NJ. BRA-M2 consists of a height adjusting bolt and a locking plate. It also includes either one or two extra shims for tension support.

The bolt in the installation set is screwed; head up, into the welded flange-plate located towards the front of the anchor bracket.

The load distributor plate is placed under the bolt; the tip of the bolt in the plate recess. The front anchor support can now be height-adjusted as required by turning the bolt.

BRA-M2 Installation set:

Consisting of:

Hexagonal bolt, locking plate,
1 or 2 shims for bracket levelling,
t = 6 mm

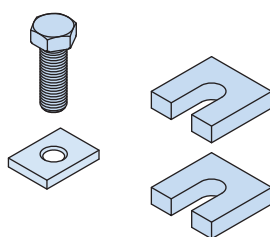

BRA-M2 is needed in addition to BRA-M1 (order separately)

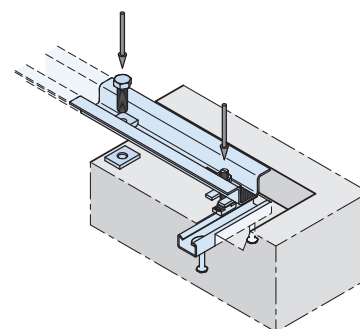

The parapet is aligned by placing the required number of shims under the rear support. The fixing bolts are tightened with the correct allowable torque only when the panel is correctly aligned.

BRA-M2 Installation set

Installation set	For bracket type	Number of shims	Hot-dip galvanized order no. 0250.-	Stainless steel A4 order no. 0250.-
BRA-M2 - 1	BRA - ... - 1	1	160-00007	160-00001
BRA-M2 - 2	BRA - ... - 2	1	160-00008	160-00002
BRA-M2 - 3	BRA - ... - 3	1	160-00009	160-00003
BRA-M2 - 4	BRA - ... - 4	1	160-00010	160-00004
BRA-M2 - 5	BRA - ... - 5	2	160-00011	160-00005
BRA-M2 - 6	BRA - ... - 6	2	160-00011	160-00005
BRA-M2 - 7	BRA - ... - 7	2	160-00012	160-00006
BRA-M2 - 8	BRA - ... - 8	2	160-00012	160-00006

Accessories for additional requirements

Further items for installation may be required for large tolerance-range or when compiling individual part lists. For available individual items please refer to the following table.

Accessories

Components		Article name	Hot-dip galvanized order no. 0250.-	Stainless steel A4 order no. 0250.-
3 mm shims	slot 17 mm	BRA SS 50/50/ 3 S=35/17	030-00014	030-00006
	slot 21 mm	BRA SS 50/50/ 3 S=35/21	030-00015	030-00007
	slot 25 mm	BRA SS 65/65/3 S=45/25	030-00023	030-00021
6 mm shims	slot 17 mm	BRA SS 50/50/ 6 S=35/17	030-00018	030-00010
	slot 21 mm	BRA SS 50/50/ 6 S=35/21	030-00019	030-00011
	slot 25 mm	BRA SS 65/65/6 S=45/25	030-00024	030-00022
Serrated washers for type	1	BRA RP 26×55×6 RL=13	050-00016	050-00011
	2 and 3	BRA RP 30×55×6 RL=17	050-00017	050-00012
	4	BRA RP 38×55×6 RL=17	050-00020	050-00015
	5	BRA RP 38×65×6 RL=21	050-00018	050-00013
	6,7 and 8	BRA RP 45×65×8 LL=21x25	050-00019	050-00014

HALFEN CONCRETE FAÇADE ANCHOR SYSTEMS

Horizontal Anchoring and Dowel Restraints: Type Overview

General information

Horizontal anchors are used for horizontal support of façade panels. Basically, a distinction is made between horizontal fixings for pressure and tensile forces of panels that are aligned with each other in parallel or at right angles, as well as for the alignment of panels arranged above or next to each other with dowel restraints.

Product selection is according to load, cross-section, stand-off spacing and accessibility.

We offer a wide range of anchors with different load groups for this application.

Spacer bolts

Page 28 – 30

Type tested

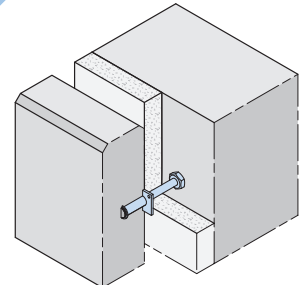

- high compression loads
- type-tested for cavities ≤ 500 mm
- Building authority approved anchorage in concrete

Tension and pressure resistant connection in the space between parallel surfaces

Adjustable restraint LD

Page 31 – 32

- cavity 60 – 300 mm
- tension load capacity $F_{Rd} = 9.0$ kN
- assumed compression load depends on the spacer bolt

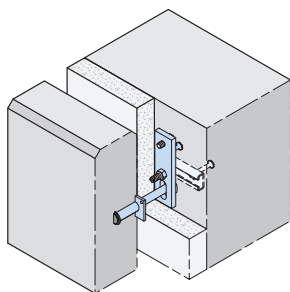

Restraint with turnbuckle SPV

Page 33

- cavity 100 – 200 mm
- tension and compression load capacity $F_{Rd} = 14.0$ kN

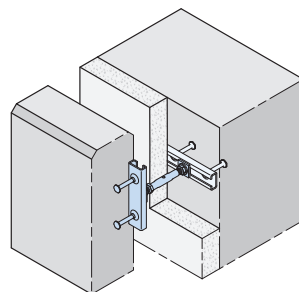

Wind anchor WDI / WDK

Page 34 – 35

- front installation
- tension and compression resistant connection
- load capacity
WDK: $F_{Rd} = 4.5$ kN
WDI: $F_{Rd} = 10.5$ kN

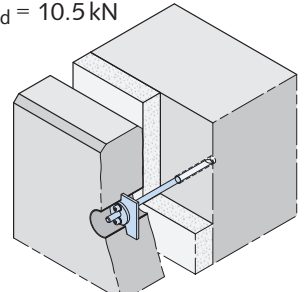

Tension and pressure resistant connection for lateral orthogonal surfaces

Restraint tie HKZ

Page 36 – 37

Hammer-head restraint in various versions for tension and compression loads

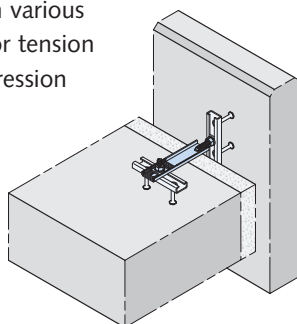

Dowel restraints

Dowel restraints HFV

Page 38 – 40

- shear load capacity $F_{Rd} = 7.5$ kN

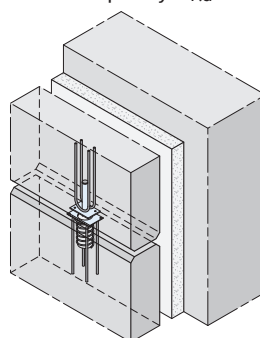

Universal tie

Universal tie ULZ

Page 41 – 43

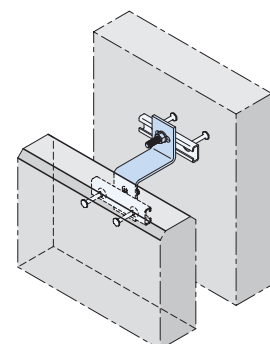

HALFEN CONCRETE FAÇADE ANCHOR SYSTEMS

Horizontal Anchoring and Dowel Restraints

DS 13

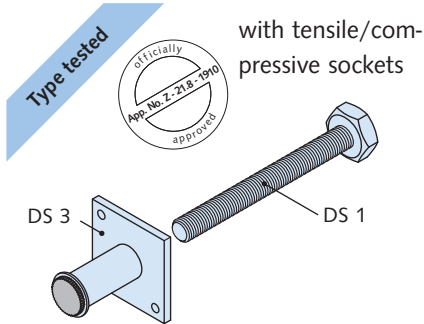

Spacer bolt DS 13

consists of:

Spacer bolt DS 1

Tensile/compressive socket DS 3

DS 18

with pressure plate

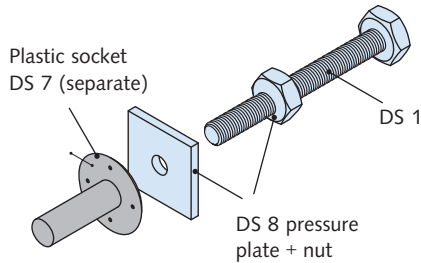

Spacer bolt DS 18

consists of:

Spacer bolt DS 1

Pressure plate DS 8 including nut

The plastic socket DS 7 must be ordered separately.

DS 25

with compressive socket, to be screwed on from the front

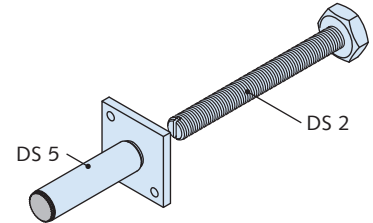

Spacer bolt DS 25

consists of:

Spacer bolt DS 2

Compressive socket DS 5

The DS 5 socket is open ended allowing the DS 2 bolt, which has a slot on the end of its shank to remain adjustable even after assembly.



DS 18 and DS 25 are not suitable for use in conjunction with adjustable restraints LD (tensile loads!)

Spacer bolts

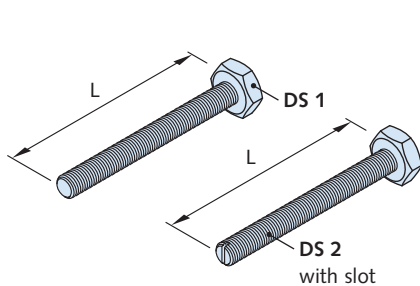

Tensile/Compressive sockets

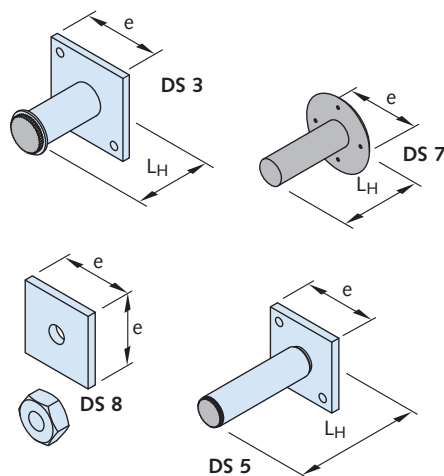

Order example:

DS 13 - 10 - 100

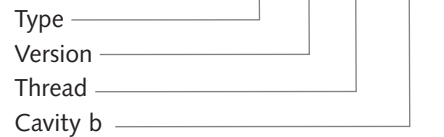

Component parts:

DS 13: Spacer bolt DS 1 and tensile/compressive socket DS 3

DS 18: Spacer bolt DS 1 and pressure plate DS 8 including nut

DS 25: Spacer bolt DS 2 and socket DS 5 accessible from panel surface

Dimensions of sockets and pressure plates [mm]

Type	M10		M12		M16		M20		M24		M27		M30	
	L _H	e	L _H	e	L _H	e	L _H	e	L _H	e	L _H	e	L _H	e
DS 3	63	50	64	50	70	50	77	70	80	70	81	80	80	90
DS 7	70	41	70	41	80	45	80	50	-	-	-	-	-	-
DS 8	-	50	-	50	-	50	-	70	-	-	-	-	-	-
DS 5	①	50	①	50	①	50	①	70	①	70	-	-	-	-

① Please provide the length and panel thickness f when ordering (for DS5, L_H = f)

HALFEN CONCRETE FAÇADE ANCHOR SYSTEMS

Horizontal Anchoring and Dowel Restraints

Dimensions of DS Spacer bolts

DS 13

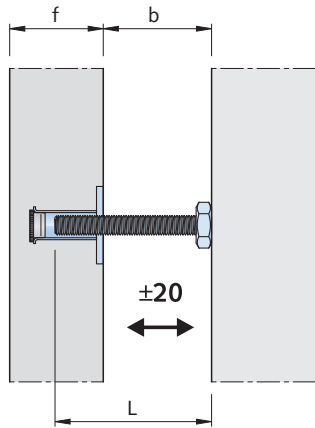

DS 18

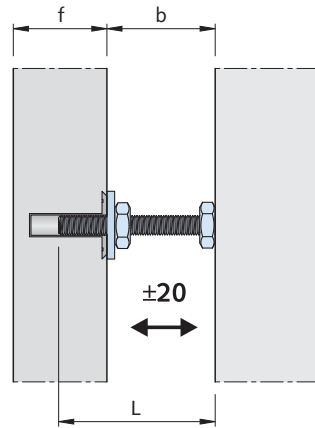

DS 25

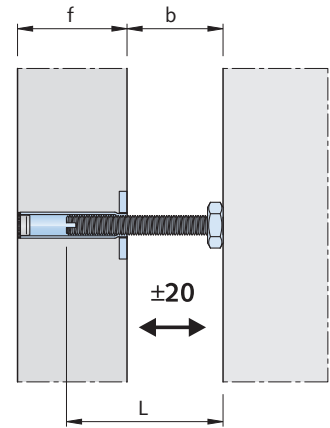

DS 1 (M10 - M20) and DS 2 (M10 - M20)

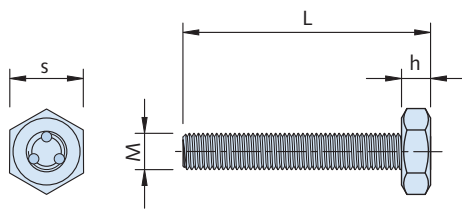

DS 1 (M24 - M30) and DS 2 (M24)

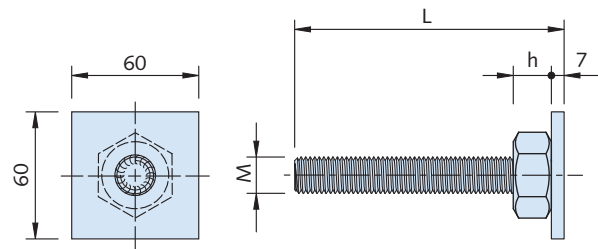

Lengths of DS Spacer bolts [mm]

Type	M10		M12		M16		M20		M24		M27		M30	
s	19		24		30		41		36		41		46	
h	8		10		13		16		19		22		24	
Spacer bolt	DS 13/25	DS 18	DS 13/25	DS 18	DS 13/25	DS 18	DS 13/25	DS 18	DS 13/25	DS 18	DS 13	DS 18	DS 13	DS 18
b = 40mm	70	90	72	92	75	95	80	100	-	-	-	-	-	-
b = 60mm	90	110	92	112	95	115	100	120	105	-	-	-	-	-
b = 80mm	110	130	112	132	115	135	120	140	125	-	-	-	-	-
b = 100mm	130	150	132	152	135	155	140	160	145	-	145	-	145	-
b = 120mm	150	170	152	172	155	175	160	180	165	-	165	-	165	-
b = 140mm	170	190	172	192	175	195	180	200	185	-	185	-	185	-
b = 160mm	190	210	192	212	195	215	200	220	205	-	205	-	205	-
b = 180mm	210	230	212	232	215	235	220	240	225	-	225	-	225	-
b = 200mm	230	250	232	252	235	255	240	260	245	-	245	-	245	-
b = 220mm	250	-	252	-	255	275	260	280	265	-	265	-	265	-
b = 240mm	-	-	-	-	275	295	280	300	285	-	285	-	285	-
b = 260mm	-	-	-	-	295	315	300	320	305	-	305	-	305	-
b = 280mm	-	-	-	-	315	335	320	340	325	-	325	-	325	-
b = 300mm	-	-	-	-	335	-	340	-	345	-	345	-	345	-
b = 320mm	-	-	-	-	355	-	360	-	365	-	365	-	365	-
b = 340mm	-	-	-	-	375	-	380	-	385	-	385	-	385	-
b = 360mm	-	-	-	-	395	-	400	-	405	-	405	-	405	-
b = 380mm	-	-	-	-	415	-	420	-	425	-	425	-	425	-
b = 400mm	-	-	-	-	435	-	440	-	445	-	445	-	445	-

Longer lengths on request

HALFEN CONCRETE FAÇADE ANCHOR SYSTEMS

Load-bearing Capacity of HALFEN Spacer Bolts Depending on the Reinforcement

Compressive load capacity $F_{D,Rd}$ [kN] for HALFEN Spacer bolts (for C 30/37, mesh reinforcement Q 188, $c_{nom} = 35\text{mm}$) without corner or edge effects																			
Spacer bolt	Panel thickness f [mm]	Cavity b [mm]																	
		60	80	100	120	140	160	180	200	220	240	260	280	300	320	340	360	380	400
M10	70	9.0	9.0	9.0	8.6	7.5	6.1	5.3	4.6	3.8	3.4	2.8	2.5	2.3	1.9	1.7	1.5	1.3	1.2
	80	9.8	9.8	9.8	8.6	7.5	6.1	5.3	4.6	3.8	3.4	2.8	2.5	2.3	1.9	1.7	1.5	1.3	1.2
	90	12.8	12.1	10.5	8.6	7.5	6.1	5.3	4.6	3.8	3.4	2.8	2.5	2.3	1.9	1.7	1.5	1.3	1.2
M12	70	9.1	9.1	9.1	9.1	9.1	9.1	9.1	8.5	7.2	6.4	5.4	4.8	4.4	3.7	3.4	2.9	2.6	2.4
	80	10.0	10.0	10.0	10.0	10.0	10.0	9.6	8.5	7.2	6.4	5.4	4.8	4.4	3.7	3.4	2.9	2.6	2.4
	90	12.4	12.4	12.4	12.4	12.4	10.8	9.6	8.5	7.2	6.4	5.4	4.8	4.4	3.7	3.4	2.9	2.6	2.4
	100	17.1	17.1	17.1	14.5	12.9	10.8	9.6	8.5	7.2	6.4	5.4	4.8	4.4	3.7	3.4	2.9	2.6	2.4
M16	80	10.9	10.9	10.9	10.9	10.9	10.9	10.9	10.9	10.9	10.9	10.9	10.9	10.9	10.7	9.9	8.5	7.9	7.3
	90	12.0	12.0	12.0	12.0	12.0	12.0	12.0	12.0	12.0	12.0	12.0	12.0	12.0	10.7	9.9	8.5	7.9	7.3
	100	16.6	16.6	16.6	16.6	16.6	16.6	16.6	16.6	16.6	16.6	14.8	13.6	12.5	10.7	9.9	8.5	7.9	7.3
	120	29.5	29.5	29.5	29.5	29.5	26.0	23.8	21.8	18.8	17.3	14.8	13.6	12.5	10.7	9.9	8.5	7.9	7.3
	140	32.6	32.6	32.6	32.5	29.9	26.0	23.8	21.8	18.8	17.3	14.8	13.6	12.5	10.7	9.9	8.5	7.9	7.3
M20	100	17.0	17.0	17.0	17.0	17.0	17.0	17.0	17.0	17.0	17.0	17.0	17.0	17.0	17.0	17.0	16.6	15.6	15.6
	120	30.1	30.1	30.1	30.1	30.1	30.1	30.1	30.1	30.1	29.0	27.1	25.2	22.0	20.5	17.8	16.6	15.6	15.6
	140	46.8	46.8	46.8	46.8	46.8	46.3	43.3	40.5	35.6	33.2	29.0	27.1	25.2	22.0	20.5	17.8	16.6	15.6
	160	54.3	54.3	54.3	54.3	52.3	46.3	43.3	40.5	35.6	33.2	29.0	27.1	25.2	22.0	20.5	17.8	16.6	15.6
M24	120	28.6	28.6	28.6	28.6	28.6	28.6	28.6	28.6	28.6	28.6	28.6	28.6	28.6	28.6	28.6	28.6	28.6	28.1
	140	45.0	45.0	45.0	45.0	45.0	45.0	45.0	45.0	45.0	45.0	45.0	45.0	43.3	38.1	36.0	31.5	29.7	28.1
	160	65.0	65.0	65.0	65.0	65.0	65.0	65.0	65.0	58.1	54.9	48.7	45.9	43.3	38.1	36.0	31.5	29.7	28.1
	180	81.5	81.5	81.5	81.5	81.1	72.7	68.9	65.3	58.1	54.9	48.7	45.9	43.3	38.1	36.0	31.5	29.7	28.1
M27	140	44.4	44.4	44.4	44.4	44.4	44.4	44.4	44.4	44.4	44.4	44.4	44.4	44.4	44.4	44.4	44.4	44.3	42.1
	160	64.4	64.4	64.4	64.4	64.4	64.4	64.4	64.4	64.4	64.4	64.4	64.4	62.7	55.6	52.9	46.6	44.3	42.1
	180	88.0	88.0	88.0	88.0	88.0	88.0	88.0	88.0	81.4	77.6	69.3	65.9	62.7	55.6	52.9	46.6	44.3	42.1
	200	110.0	110.0	110.0	110.0	110.0	99.5	95.0	90.7	81.4	77.6	69.3	65.9	62.7	55.6	52.9	46.6	44.3	42.1
M30	160	65.9	65.9	65.9	65.9	65.9	65.9	65.9	65.9	65.9	65.9	65.9	65.9	65.9	65.9	65.9	62.2	59.4	56.7
	180	89.8	89.8	89.8	89.8	89.8	89.8	89.8	89.8	89.8	89.8	89.8	86.1	82.3	73.5	70.2	62.2	59.4	56.7
	200	117.3	117.3	117.3	117.3	117.3	117.3	117.3	115.9	104.6	100.2	90.0	86.1	82.3	73.5	70.2	62.2	59.4	56.7

The load capacities have been reduced compared with the type test to allow for unfavourable actions during installation.

Compressive load capacity red $F_{D,Rd}$ [kN] for HALFEN Spacer bolts (for C 30/37, mesh reinforcement Q 188, $c_{nom} = 35\text{mm}$), <u>minimum edge distances</u> $r_{1/2,min}$													
Spacer bolt	Edge distance $r_{1/2,min}$ [mm]	Panel thickness f [mm]											
		70	80	90	100	110	120	130	140	150	160	180	200
M10	50	5.0	5.5	6.0	6.4	8.3	10.5	12.8	13.3	13.3	13.3	13.3	13.3
M12	50	5.0	5.5	5.9	6.4	8.1	10.2	12.6	15.1	17.9	20.4	20.4	20.4
M16	50	5.0	5.5	5.9	6.3	7.9	10.0	12.3	14.9	17.6	20.6	27.3	32.6
M20	70	6.8	7.4	8.0	8.6	9.2	11.1	13.6	16.3	19.3	22.4	29.4	37.4
M24	70	6.7	7.4	8.0	8.5	9.1	10.6	13.1	15.8	18.6	21.8	28.7	36.5
M27	80	7.7	8.4	9.1	9.8	10.4	11.0	13.4	16.1	19.1	22.3	29.3	37.3
M30	90	8.7	9.5	10.3	11.0	11.7	12.4	14.2	17.1	20.2	23.4	30.7	38.9

The load capacities red $F_{D,Rd}$ shown must not be higher than $F_{D,Rd}$ for the actual wall cavity b (see top table).

DS 3: Tensile load capacity $F_{Z,Rd}$ [kN] (C30/37) for $r_1 / r_2 \geq r_0$											
Size	Edge distance r_0 [mm]	Slab thickness f [mm]									
		70	80	90	100	120	130	140	150	≥ 160	
M10	85	9.0	9.8	10.6	11.4	12.3	12.3	12.3	12.3	12.3	12.3
M12	90	9.1	10.0	10.8	11.6	12.7	12.7	12.7	12.7	12.7	12.7
M16	95	9.9	10.9	11.7	12.6	14.2	14.7	14.7	14.7	14.7	14.7
M20	105	10.8	11.9	12.8	13.8	15.5	16.4	17.2	17.2	17.2	17.2
M24	110	11.2	12.3	13.3	14.2	16.1	17.0	17.8	18.3	18.3	18.3
M27	115	11.4	12.5	13.5	14.5	16.3	17.2	18.1	18.9	18.9	18.9
M30	120	11.7	12.8	13.9	14.9	16.8	17.7	18.6	19.5	19.5	19.5

Mesh reinforcement

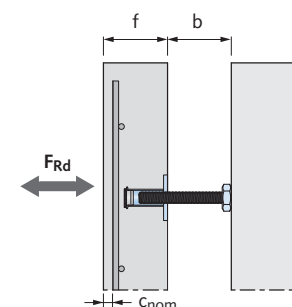
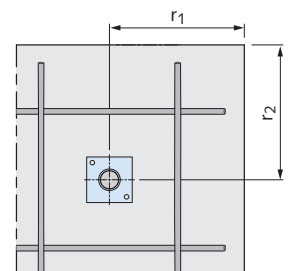

Please use our **FPA-Software** dimensioning software to calculate exact loads and load capacities

HALFEN CONCRETE FAÇADE ANCHOR SYSTEMS

Tension and Pressure Resistant Connection in the Space Between Parallel Surfaces

HALFEN LD Adjustable restraint

Application: for tensile and compressive loads

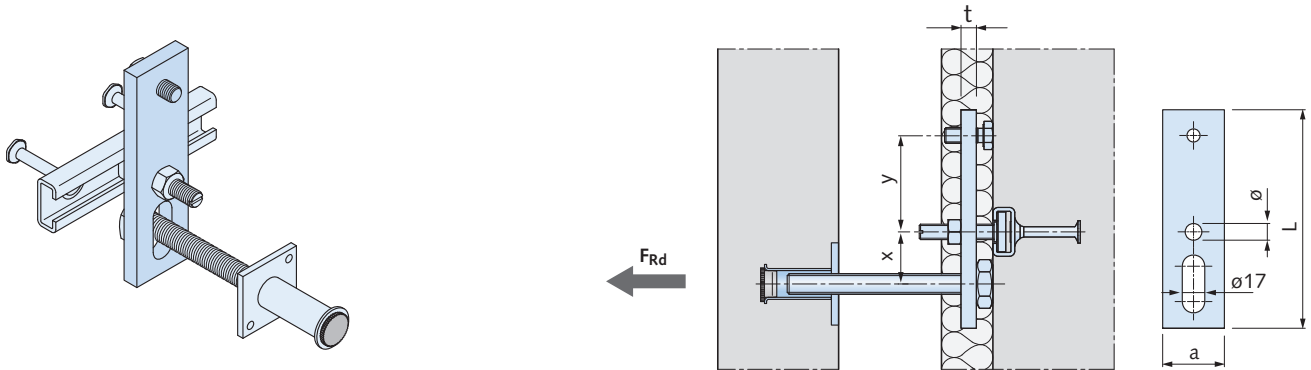

Order example

Article name: **LD - 3,5**

Type _____

Load group _____

Order the spacer bolt separately, refer to page 28

Component part

Adjustable restraint with set-screw

HALFEN approved dowels can also be used instead of HALFEN Cast-in channel and HALFEN Bolts.

The HALFEN LD Adjustable restraint can be combined with the M10, M12 and M16 spacer bolts.
When using with M10 spacer bolts, DIN 9021 washers must be fitted between the bolt head and the slot (order separately).

Installation

1. Insert the spacer bolt through the slot in the bracket (a washer is required for M10 thread spacer bolts).
2. Screw the spacer bolt into the socket and adjust.
3. Pre-mount on the HALFEN Cast-in channel.
4. Adjust the screw so that the panel is parallel to the main construction.
5. Tighten the HALFEN Bolt.

Dimension table HALFEN LD Adjustable restraint

Type	Load group	Load capacity F_{Rd} [kN]	L [mm]	a [mm]	t [mm]	$x \pm 15$ [mm]	y [mm]	\emptyset [mm]	Recommended fixing ①	HALFEN Bolt ②
LD	2.0	3.00	161	40	10	38	75	11	HTA-CE 28/15	HS 28/15 M10x40
	3.5	5.25	170	48	12	40	75	13	HTA-CE 38/17	HS 38/17 M12x50
	6.0	9.00	182	60	15	49	75	17	HTA-CE 49/30	HS 50/30 M16x60

① Short items 150, 200 and 250mm long must be ordered separately. Respective boundary conditions must be considered when verifying the anchorage.

② HALFEN Bolts must be ordered separately

For allowable compressive forces, see "spacer bolts" on page 30

HALFEN CONCRETE FAÇADE ANCHOR SYSTEMS

Tension and Pressure Resistant Connection in the Space Between Parallel Surfaces

HALFEN LD-A Adjustable restraint anchor

Application: tension and pressure resistant connection

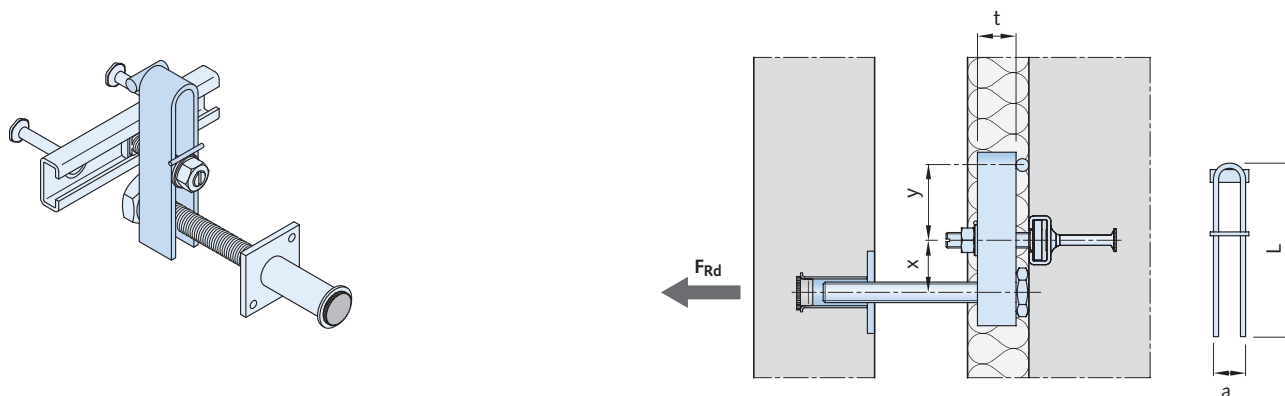

Order example

Article name: **LD-A - 3.5 - 12**

Type _____

Load group _____

Thread of the spacer bolt _____

Component part

Clamping fork

Order the spacer bolt separately, refer to page 28

Application

Tension and pressure resistant connection of curtain facing panels with on-site concrete element production. Adjustable in three directions.

HALFEN LD-A Adjustable restraint anchor

Type	Load group	Load capacity F_{Rd} [kN]	L [mm]	a [mm]	t [mm]	x ± 15 [mm]	y [mm]	Spacer bolt	Recommended fixing ①	HALFEN Bolt ②	Washer DIN
LD-A	1.8	2.70	130	21	22	40	60	M12	HTA-CE 28/15	HS 28/15 M10×50	DIN 9021
	1.8	2.70	130	25	22	40	60	M16	HTA-CE 28/15	HS 28/15 M10×50	DIN 9021
	3.5	5.25	135	21	30	40	60	M12	HTA-CE 38/17	HS 38/17 M12×80	DIN 125
	3.5	5.25	135	25	30	40	65	M16	HTA-CE 38/17	HS 38/17 M12×80	DIN 9021
	3.5	5.25	135	29	30	40	65	M20	HTA-CE 38/17	HS 38/17 M12×80	DIN 9021
	6.0	9.00	135	27	35	40	60	M16	HTA-CE 49/30	HS 50/30 M16×80	DIN 125
	6.0	9.00	135	31	35	40	60	M20	HTA-CE 49/30	HS 50/30 M16×80	DIN 125

① Short items 150, 200 and 250mm in length must be ordered separately. Respective boundary conditions must be considered when verifying the anchorage.

② HALFEN Bolts must be ordered separately

For allowable compressive forces, see "spacer bolts" on page 30

HALFEN CONCRETE FAÇADE ANCHOR SYSTEMS

Tension and Pressure Resistant Connection in the Space Between Parallel Surfaces

HALFEN SPV Restraint with turnbuckle

Application; tension and pressure resistant connection

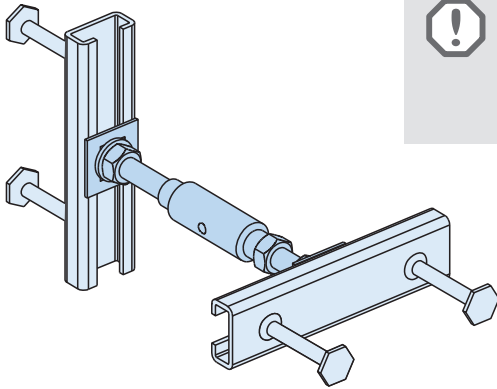

Ensure sufficient screw depth:
 M12 → ≥ 10 mm
 M16 → ≥ 13 mm

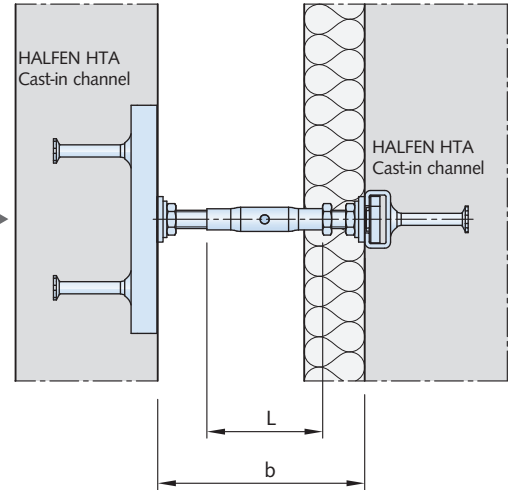

Product characteristics

The turnbuckle SPV Restraint is suitable for taking up compressive and tensile loads up to $F_{Ed} = 14.0 \text{ kN}$ and for clearances up to 200 mm. Spacings, within the set range, can be continuously adjusted by turning the right/left hand threaded clamping sleeve. The clamp is fitted to the building components using HALFEN Cast-in channels (order separately).

Included parts

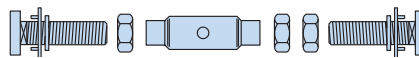

- turnbuckle SPH
- 2 HALFEN T-head bolts (1 right-hand thread, 1 left-hand thread)
- 3 flat surface nuts
- 2 washers and
- 2 locking washers SIC

Order example

Article name: **SPV - 7.0 - 100 - A4**

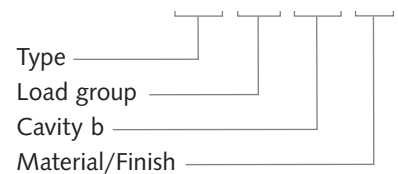

HALFEN Cast-in channels must be ordered separately

HALFEN SPV Restraint with turnbuckle										
Load group		5.0			7.0			10.0		
Load capacity F_{Rd} [kN]		±7.5			±10.0			±15.0		
Type	Cavity	HALFEN Spacer bolt left-hand thread	Turn-buckle	HALFEN Spacer bolt right-hand thread	HALFEN Spacer bolt left-hand thread	Turn-buckle	HALFEN Spacer bolt right-hand thread	HALFEN Spacer bolt left-hand thread	Turn-buckle	HALFEN Spacer bolt right-hand thread
	b [mm]	M12 [mm]	L [mm]	M12 [mm]	M16 [mm]	L [mm]	M16 [mm]	M16 [mm]	L [mm]	M16 [mm]
SPV	100 ±10 ②	50	60	40	50	60	40	-	-	-
	120 ±15	50	75	40	50	75	40	-	-	-
	140 ±15	50	75	60	50	75	60	80	60	50
	160 ±15	50	95	60	50	95	60	80	75	50
	180 ±15	50	115	60	50	115	60	80	95	50
	200 ±15	50	135	60	50	135	60	80	115	50
Recommended fixing		HTA-CE 38/17 ①			HTA-CE 38/17 ①			HTA-CE 49/30 ①		

① Short elements 150, 200 and 250. The respective boundary conditions must be taken into consideration when verifying the anchorage.

② Minimum tolerance is limited for load group 7.0

HALFEN CONCRETE FAÇADE ANCHOR SYSTEMS

Tension and Pressure Resistant Connection in the Cavity Between Parallel Surfaces

HALFEN WDK - 3.0 Plastic wind anchor for push-through installation

Application; tension and pressure resistant connection

- ① Recess tube
- ② Extension
- ③ Threaded tube
- ④ Extension
- ⑤ Ring plate
- ⑥ Mortar cartridge
- ⑦ Threaded rod/M10 thread
- ⑧ Plug with or without rim

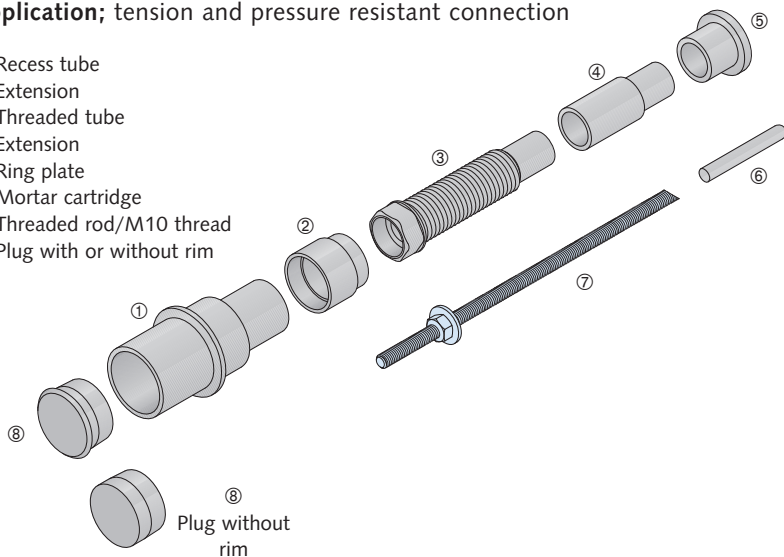

Load group = 3.0
 Load capacity $F_{Rd} = \pm 4.5 \text{ kN}$
 (determined in tension and pressure tests)

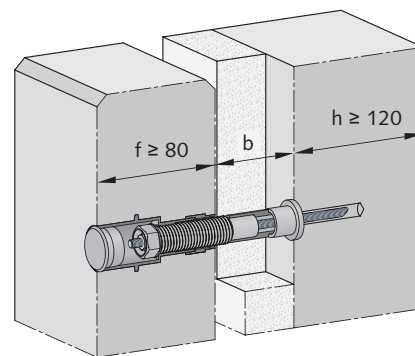

Installation parts

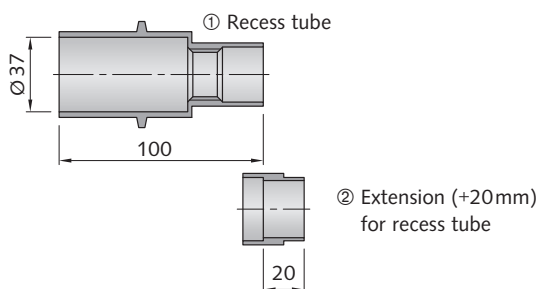

Component parts

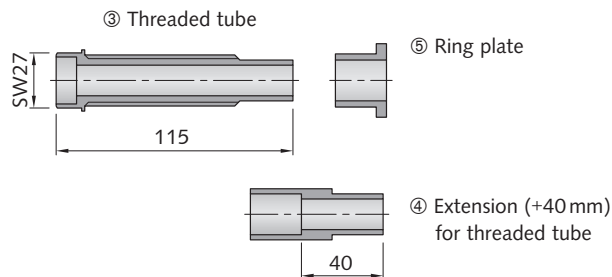

HALFEN WDK - 3.0 Plastic wind anchor, selection table depending on f and b

Article description		⑧ Plug with rim *	① Recess tube	① Recess tube ② + extension	② Extension	③ Threaded tube ⑤ + ring plate	④ Extension **	⑦ Threaded rod ⑥ + mortar cartridge	
Order no. f	b	WDK-STR 0250.060-00001	WDK-E-3.0-100 0247.010-00001	WDK-E-3.0-120 0247.010-00002	WDK-E-3.0-VRL20 0247.010-00003	WDK-M 0247.020-00001	WDK-M-3.0-VRL40 0247.020-00004	Type	0430.010-
80	60	1	1	-	-	1	-	1	WDK-DUE-3.0-100- 20/ 60-A4 00014
80	80	1	1	-	-	1	-	1	WDK-DUE-3.0-100- 20/ 60-A4 00014
80	100	1	1	-	-	1	1	1	WDK-DUE-3.0-100- 70/100-A4 00015
80	120	1	1	-	-	1	1	1	WDK-DUE-3.0-100- 70/100-A4 00015
100	60	1	1	-	-	1	-	1	WDK-DUE-3.0-100- 20/ 60-A4 00014
100	80	1	1	-	-	1	1	1	WDK-DUE-3.0-100- 70/100-A4 00015
100	100	1	1	-	-	1	1	1	WDK-DUE-3.0-100- 70/100-A4 00015
100	120	1	1	-	-	1	2	1	WDK-DUE-3.0-100-110/140-A4 00016
120	60	1	-	1	-	1	1	1	WDK-DUE-3.0-100- 70/100-A4 00015
120	80	1	-	1	-	1	1	1	WDK-DUE-3.0-100- 70/100-A4 00015
120	100	1	-	1	-	1	2	1	WDK-DUE-3.0-100-110/140-A4 00016
120	120	1	-	1	-	1	2	1	WDK-DUE-3.0-100-110/140-A4 00016
120	140	1	-	1	-	1	3 **	1	WDK-DUE-3.0-100-150/180-A4 00017

* Alternative: Plug without rim WDK-STO, order no. 0250.060-00002

** When using more than two extensions ④, additional spacer bolts (e.g. DS 13) spaced approx. 15 - 30 cm apart must be used to take up the pressure.

HALFEN CONCRETE FAÇADE ANCHOR SYSTEMS

Tension and Pressure Resistant Connection in the Cavity Between Parallel Surfaces

HALFEN WDI Wind anchor for push-through installation

Application: tension and pressure resistant connection

- ① Pressure distribution plate
- ② Recess tubes
- ③ Fixing plate
- ④ Allen screws
- ⑤ Threaded rod, M12 thread

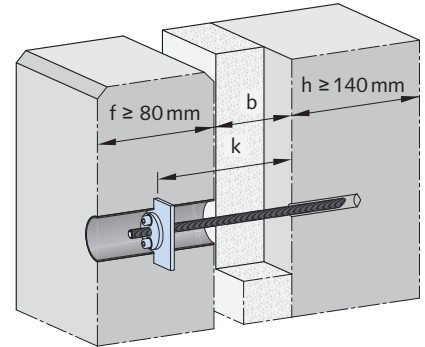
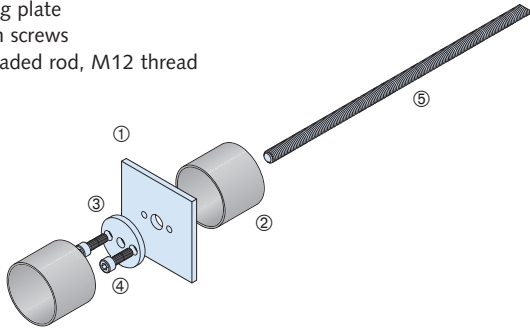

Load group = 7.0, Load capacity $F_{Rd} = \pm 10.5 \text{ kN}$
 Compression load capacity applies only for $k \leq 270 \text{ mm}$.
 For $k > 270 \text{ mm}$, pressure loads must be verified.

Installation parts

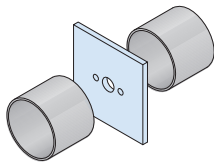

WDI-7.0-E, order no. 0247.030-f
 includes:

- ① 1 × Pressure distribution plate
- ② 2 × Recess tube

Please provide dimension "f"
 when ordering.

Installation accessories

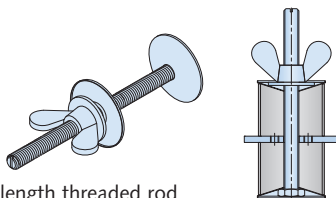

L = length threaded rod

WDI-Z2,
 L=240 order no. 0250.110-00010
 L=330 order no. 0250.110-00018
 L=490 order no. 0250.110-00019
 Fitting for holding components
 accurately in place while concreting.
 Threaded rod M14.

Installation parts

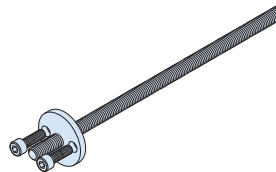

WDI-7.0-M, order no. 0247.040-f-b
 includes:

- ③ 1 × Fixing plate
- ④ 2 × Allen screw
- ⑤ 1 × Threaded rod

Please provide dimension "f"
 and "b" when ordering.

Setting tool

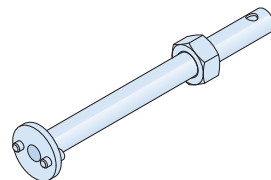

WDI-Z4, order no. 0250.110-00011

Mortar set

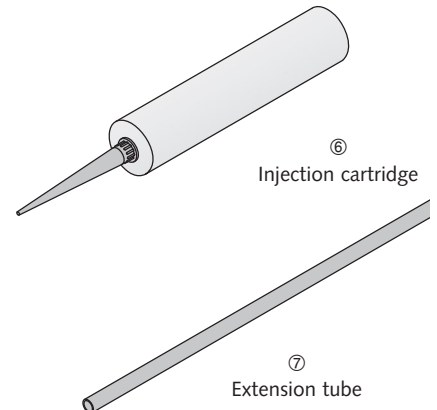

Injection Set

Order no. 0250.110-00006
 sufficient for approx. 30 drill holes,
 consists of:
 ⑥ 1 pcs. Injection cartridge including
 static mixer
 ⑦ 1 pcs. Extension tube 1 m

For installation, please refer to the
 assembly instructions.



Multi-language assembly instructions can be found
 at www.halfen.com/downloads/brochures.
 Or simply scan the code and select the required document.

HALFEN CONCRETE FAÇADE ANCHOR SYSTEMS

Tension Resistant Connection for Orthogonal Surfaces

HALFEN HKZ Restraint tie

Application: for tensile loads only

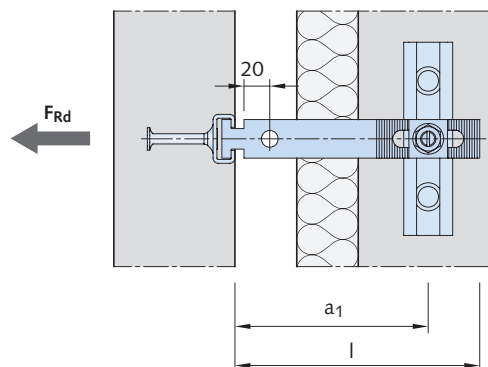
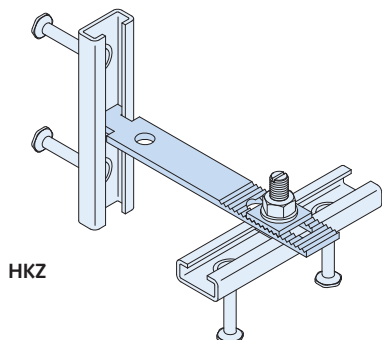

Product characteristics

The serration in the tie and the counter-plate guarantee an efficient static load transmission. HALFEN Cast-in channels are cast in at right-angles to each other to ensure three-dimensional adjustability.

Order example

Article name: **HKZ-38/17 - 100 - A4**
 Type _____
 Cavity a_1 _____
 Material _____

Component parts

- hammer-head tie with serration
- serrated counter-plate

Order the HALFEN Cast-in channels and HALFEN Bolts separately

HALFEN HKZ Restraint tie

Characteristics:		Type selection: A4 = stainless steel	Dimensions				Recommended fixing ①
Load group	Load capacity (tension) F_{Rd} [kN]	Type	Length l [mm]	Cavity a_1 [mm]	Tolerance [mm]	Slot [mm]	
3.5	4.9	HKZ 28/15 - 50 - A4	90	50	$a_1 \pm 20$	11×55	HTA-CE 28/15 HS 28/15 M10×30 torque $M_A = 15 \text{ Nm}$
		HKZ 28/15 - 75 - A4	115	75			
		HKZ 28/15 - 100 - A4	140	100			
		HKZ 28/15 - 125 - A4	165	125			
		HKZ 28/15 - 150 - A4	190	150			
		HKZ 28/15 - 175 - A4	215	175			
		HKZ 28/15 - 200 - A4	240	200			
		HKZ 28/15 - 225 - A4	265	225			
7.0	9.8	HKZ 38/17 - 75 - A4	115	75	$a_1 \pm 20$	13×55	HTA-CE 38/17 HS 38/17 M12×50 torque $M_A = 25 \text{ Nm}$
		HKZ 38/17 - 100 - A4	140	100			
		HKZ 38/17 - 125 - A4	165	125			
		HKZ 38/17 - 150 - A4	190	150			
		HKZ 38/17 - 175 - A4	215	175			
		HKZ 38/17 - 200 - A4	240	200			
		HKZ 38/17 - 225 - A4	265	225			
		HKZ 38/17 - 250 - A4	290	250			
		HKZ 38/17 - 275 - A4	315	275			
		HKZ 38/17 - 300 - A4	340	300			

① 150, 200 or 250 mm short channel lengths or building regulation approved dowels. The respective boundary conditions must be taken into consideration when verifying the anchor.

HALFEN CONCRETE FAÇADE ANCHOR SYSTEMS

Tension and Pressure Resistant Connection for Orthogonal Surfaces

HALFEN HKZ-GF and HKZ-GU Restraint tie

Application: For tensile and compressive loads

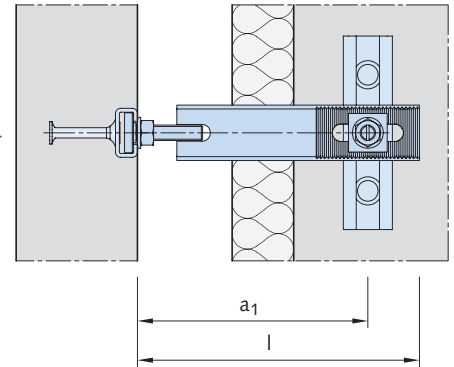
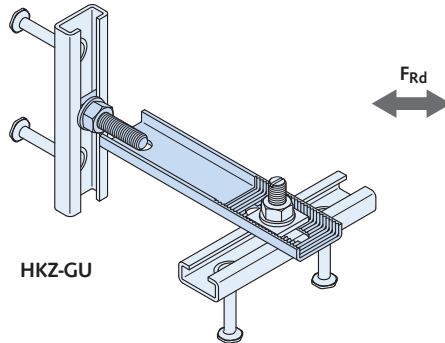
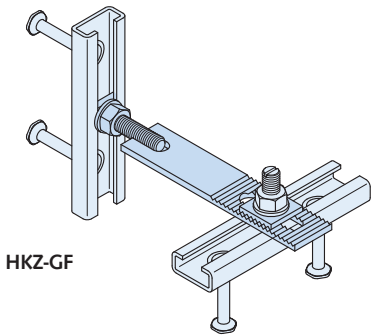

Product characteristics

The serration in the strap and the counter-plate guarantee an effective static load transmission. Using HALFEN Bolts and serrated plates to attach the system together with HALFEN Cast-in channels guarantee a positive, slip-free wind-load transmission. Full three-dimensional adjustability during installation.

Order example

Article name: **HKZ-GU-50/30 - 225 - A4**
 Type _____
 Cavity a_1 _____
 Material _____

Component parts

- tie with serrations, welded-on threaded rod and pre-assembled tapped plate, nut and washer
- serrated counter-plate

Order the HALFEN Cast-in channels and HALFEN Bolts separately

HALFEN HKZ-GF and HKZ-GU Restraint tie

Characteristics:		Type selection: A4 = stainless steel Type	Dimensions				Recommended fixing ①
Load group	Load capacity (tension / compression) F_{Rd} [kN]	Type	Length l [mm]	Cavity a_1 [mm]	Tolerance [mm]	Slot [mm]	
3.5	4.9	HKZ - GF 28/15 - 75 - A4	115	75	$a_1 \pm 20$	11×55	HTA-CE 28/15 HS 28/15 M10×30 torque $M_A = 15 \text{ Nm}$
		HKZ - GF 28/15 - 100 - A4	140	100			
		HKZ - GF 28/15 - 125 - A4	165	125			
		HKZ - GF 28/15 - 150 - A4	190	150			
		HKZ - GF 28/15 - 175 - A4	215	175			
7.0	9.8	HKZ - GF 38/17 - 100 - A4	140	100	$a_1 \pm 20$	13×55	HTA-CE 38/17 HS 38/17 M12×50 torque $M_A = 25 \text{ Nm}$
		HKZ - GF 38/17 - 125 - A4	165	125			
		HKZ - GF 38/17 - 150 - A4	190	150			
		HKZ - GF 38/17 - 175 - A4	215	175	$a_1 \pm 20$	13×60	
		HKZ - GU 38/17 - 200 - A4	240	200			
		HKZ - GU 38/17 - 225 - A4	265	225			
12.0	16.8	HKZ - GU 50/30 - 200 - A4	240	200	$a_1 \pm 20$	17×60	HTA-CE 49/30 HS 50/30 M16×50 torque $M_A = 60 \text{ Nm}$
		HKZ - GU 50/30 - 225 - A4	265	225			
		HKZ - GU 50/30 - 250 - A4	290	250			
		HKZ - GU 50/30 - 275 - A4	315	275			
		HKZ - GU 50/30 - 300 - A4	340	300			

① 150, 200 or 250 mm short channel lengths or building regulation approved dowels.
 The respective boundary conditions must be taken into consideration when verifying the anchorage.

HALFEN CONCRETE FAÇADE ANCHOR SYSTEMS

HALFEN HFV Dowel Restraints in Plastic

Oval sleeve HFV 1

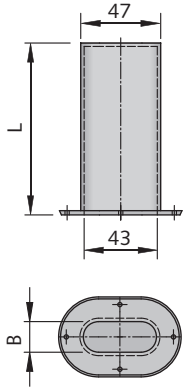

Material: Plastic

Dowel sleeve HFV 5

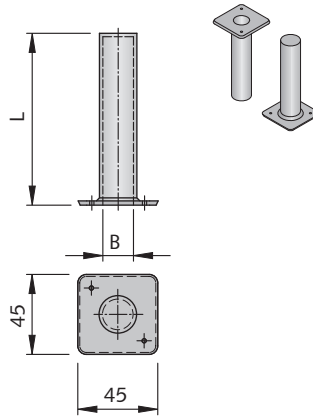

Material: Plastic

Grouting sleeve HFV 9

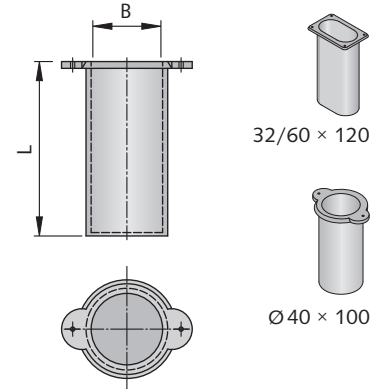

Fill with mortar after positioning the dowel.

Material: Plastic

Loose dowel HFV 3

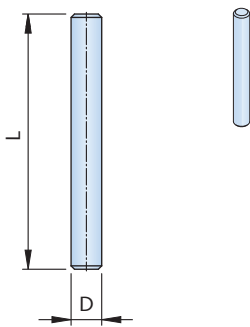

Material: Stainless steel A4

Spiral reinforcement HFV-B

for HFV 1, HFV 5 and HFV 9

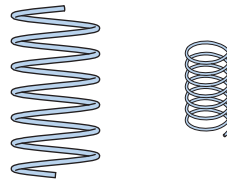

Material: Stainless steel A4

Spiral reinforcement 60 × 80 mm

Type	Order no. 0249.100-
HFV-B-WB	00001
HFV-B-A4	00002

Cap HFV-K

for HFV 1

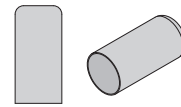

Material: Plastic

CAP HFV-K

Type	Order no. 0249.110-
HFV-K 2,5	00001
HFV-K 5,0	00002

HALFEN HFV Dowel restraints (plastic)

Type	Upper and lower parts								Dowel HFV 3	
	HFV 1		HFV 5		HFV 9				D	L
load group	B [mm]	L [mm]	B [mm]	L [mm]	B [mm]	L [mm]	B [mm]	L [mm]	[mm]	[mm]
2.5	18	100	16.5	100	40	100	32/60	120	16	170
5.0	22	100	20.5	100	40	100	32/60	120	20	170

Design load capacities F_{Rd} [kN] ①

Load group	HFV Type	Slab thickness f [mm]							
		Without reinforcement				With HFV B Spiral reinforcement			
		80	100	120	140	80	100	120	140
2.5	HFV 1	1.5	2.5	3.6	3.7	2.7	3.7	3.7	3.7
	HFV 5	2.4	3.3	3.7	3.7	3.7	3.7	3.7	3.7
	HFV 9	2.7	3.7	3.7	3.7	3.7	3.7	3.7	3.7
5.0	HFV 1	1.5	2.5	3.6	4.8	2.8	4.0	5.2	6.6
	HFV 5	2.5	3.6	4.8②	6.0②	5.5	6.7	7.5	7.5
	HFV 9	2.7	3.7	4.9②	6.3②	4.9	6.1	7.3	7.5

① The loads apply to C30/37 with single layer rebar and a cavity width ≤ 20 mm (for C35/45 the loads can be increased by 10%)

② with double layer rebar (edge rebar near to the sleeve), the full bearing capacity (7.5 kN) can be assumed for slab thickness ≥ 120 mm even without additional reinforcement

HALFEN CONCRETE FAÇADE ANCHOR SYSTEMS

HALFEN HFV Dowel Restraints in Stainless Steel for Thin Building Elements

Slotted plate HFV 2

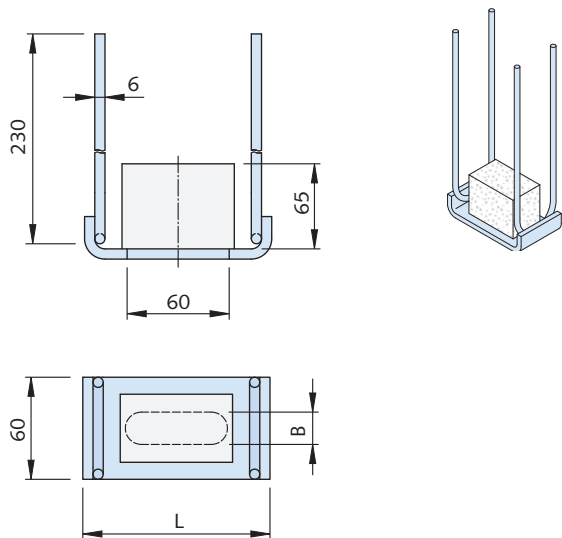

Material: Stainless steel A4
Recess former: polystyrene

Mortar sleeve HFV 4

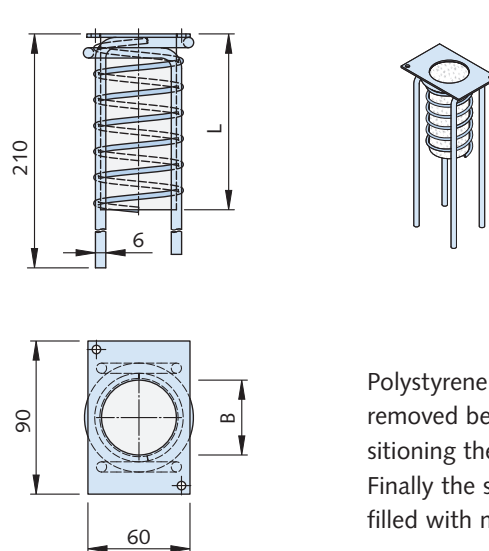

Polystyrene must be removed before positioning the dowel. Finally the sleeve is filled with mortar.

Material: Stainless steel A4
Recess former: polystyrene

Solid dowel HFV 7

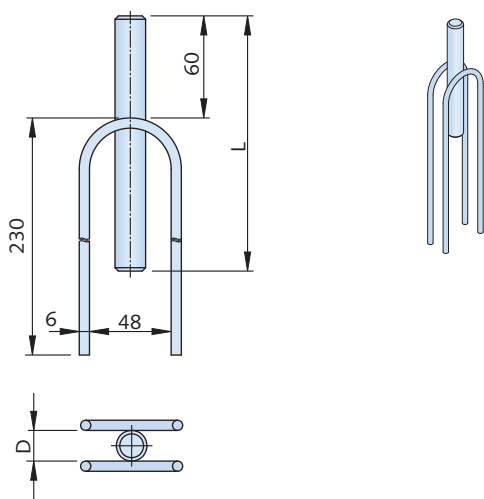

Material: Stainless steel A4

Dowel sleeve HFV 8

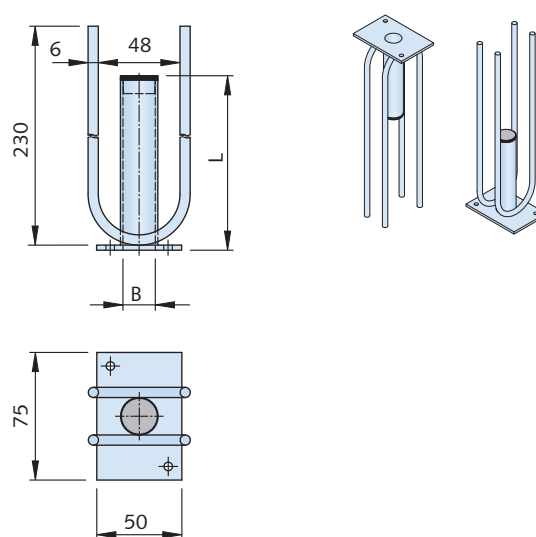

Material: Stainless steel A4









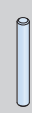

HALFEN HFV Dowel restraints (stainless steel)

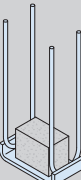
Type	HFV 2		HFV 4		HFV 7		HFV 8	
	B [mm]	L [mm]	B [mm]	L [mm]	D [mm]	L [mm]	B [mm]	L [mm]
2.5	17	110	44	100	16	170	17	100
5.0	21	120	44	100	20	170	21	100

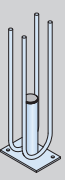
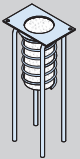
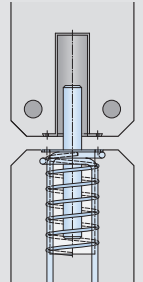
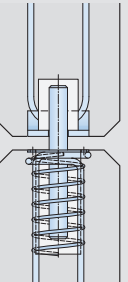
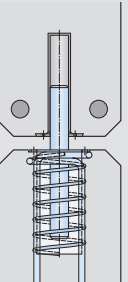
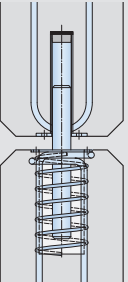
① For a joint width ≤ 20mm and a minimum slab thickness of 80mm

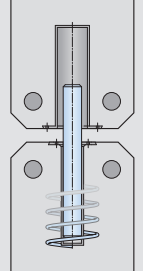
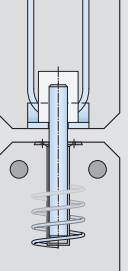
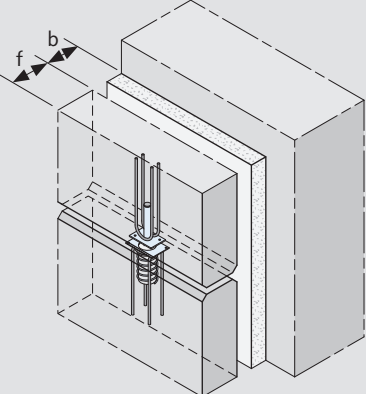
HALFEN CONCRETE FAÇADE ANCHOR SYSTEMS

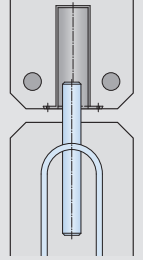
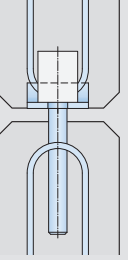
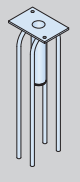
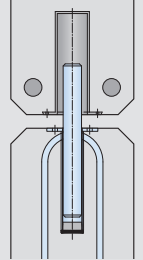
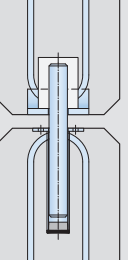
Possible Combinations of HALFEN HFV Dowel Restraints

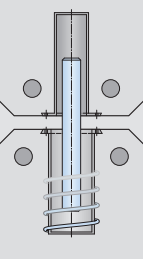
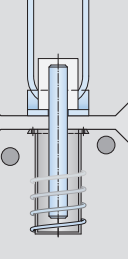
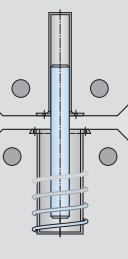
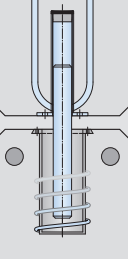
Dowel	HALFEN HFV Dowel restraints – upper parts				
	HFV 1	HFV 2	HFV 5	HFV 8	
HFV 3 					
HFV 4 					
HFV 5 			<p>e.g. Combination</p> <p>Upper part HFV 8</p> <p>Dowel HFV 3</p> <p>Lower part HFV 4</p> 		
HFV 7 ①  <p>Combination without HFV 3</p>			<p>Order example: HFV - 8 3 4 - 2.5</p> <p>Restraint —————</p> <p>Upper part, type ———</p> <p>Dowel, type —————</p> <p>Lower part, type ———</p> <p>Load group —————</p>		
HFV 8 					
HFV 9 					

① Available on request

HALFEN CONCRETE FAÇADE ANCHOR SYSTEMS

ULZ Universal Ties

HALFEN ULZ Serrated universal ties – basic body with locking plate

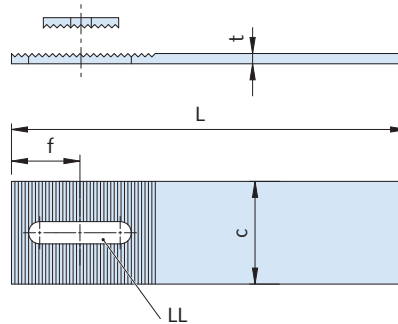
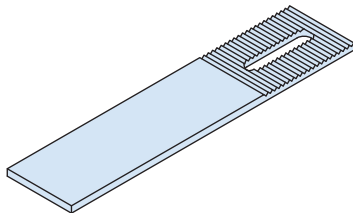

Order example: **ULZ - 40 - 6 - 200**

Type _____
 Width c _____
 Thickness t _____
 Length L _____

Material: Stainless steel A4 S235,
 higher strength classes
 on request

HALFEN ULZ Serrated universal tie

Type	L [mm]	c [mm]	t [mm]	f [mm]	Slot [mm]	Locking plate 	Load capacity of the serration F_{Rd} [kN] ①
ULZ	183	30	5	40	55/11	25/25/4 Ø11	4.9 torque $M_A = 15 \text{ Nm}$
	233						
	283						
	333						
	200	40	6	45	55/13	30/30/5 Ø13	9.8 torque $M_A = 25 \text{ Nm}$
	240						
	280						
	320						
	450	60	6	40	60/17	35/40/5 Ø17	16.8 torque $M_A = 60 \text{ Nm}$
	240						
	320						
	450						
240	80	8	45	60/17	35/40/5 Ø17	16.8 torque $M_A = 60 \text{ Nm}$	
320							
450							

Other dimensions on request

① Load capacity of the tie depends on the bend

HALFEN CONCRETE FAÇADE ANCHOR SYSTEMS

ULZ Universal Ties: Factory Drawings

Delivery options for the ULZ Universal tie – on request

1 Flat-tie

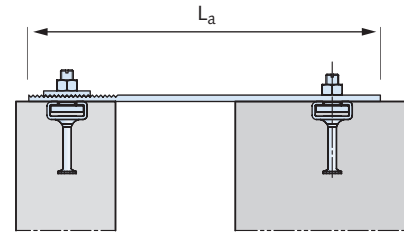
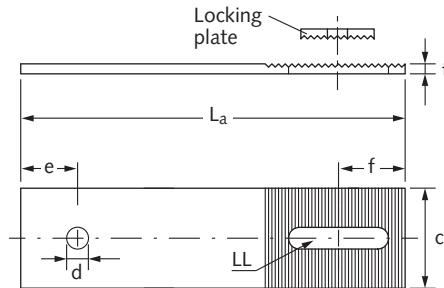
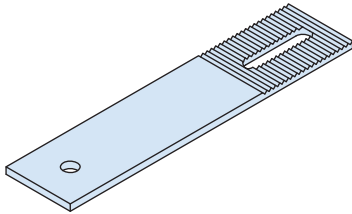

2 L-tie

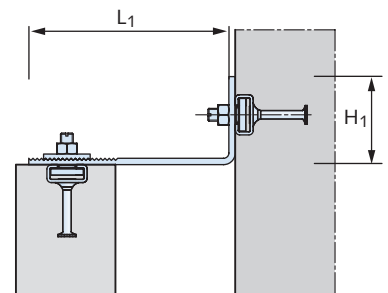
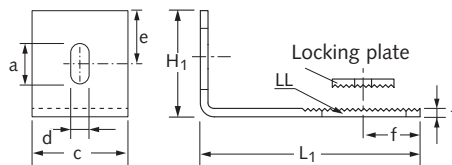
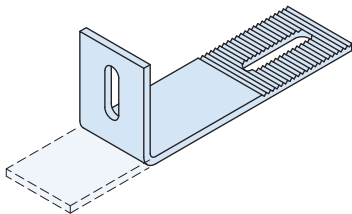

3 Z-tie

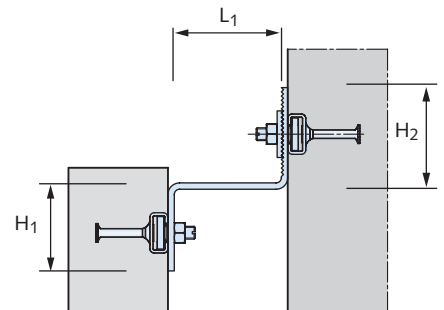
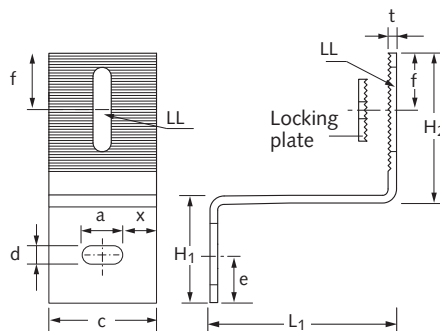
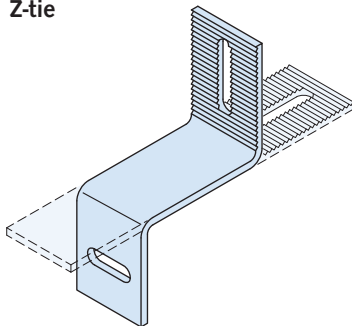

4 U-tie

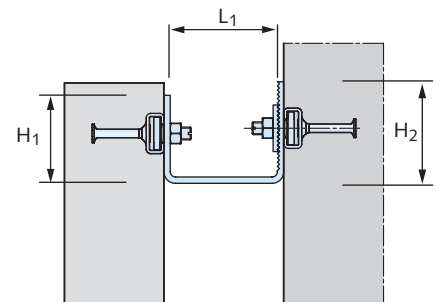
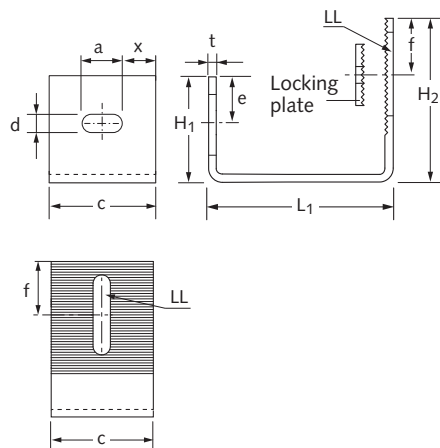
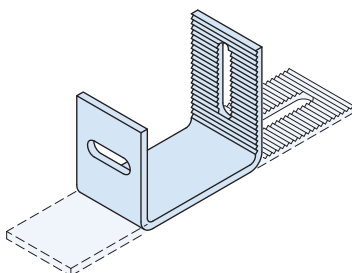

LL = Adjustment slot

Please provide dimensions when ordering. An order form is provided on page 43.

HALFEN CONCRETE FAÇADE ANCHOR SYSTEMS

Building Physics

Calculation of thermal transmission coefficient

Calculation of the thermal transmission coefficient for HALFEN Façade panel anchors and pressure bolts is according to the illustrated method.



Confirmed by approved certified tests S 275/09.2-2

Anchor parameter A_{eq}				
Type HALFEN FPA	Load group	A_{eq}	Type HALFEN Spacer bolt	A_{eq}
FPA-3 FPA-5	5.0	0.95	DS - M10	1.1
	8.0	1.2	DS - M12	1.8
	11.5	1.7	DS - M16	3.4
	16.0	2.1	DS - M20	6.4
	22.0	2.3	DS - M24	6.8
	34.0	3.4	DS - M27	9.1
	46.0	5.5	DS - M30	12.4
	56.0	6.0	-	-

Diagram: Characteristic value for insulation material d_k

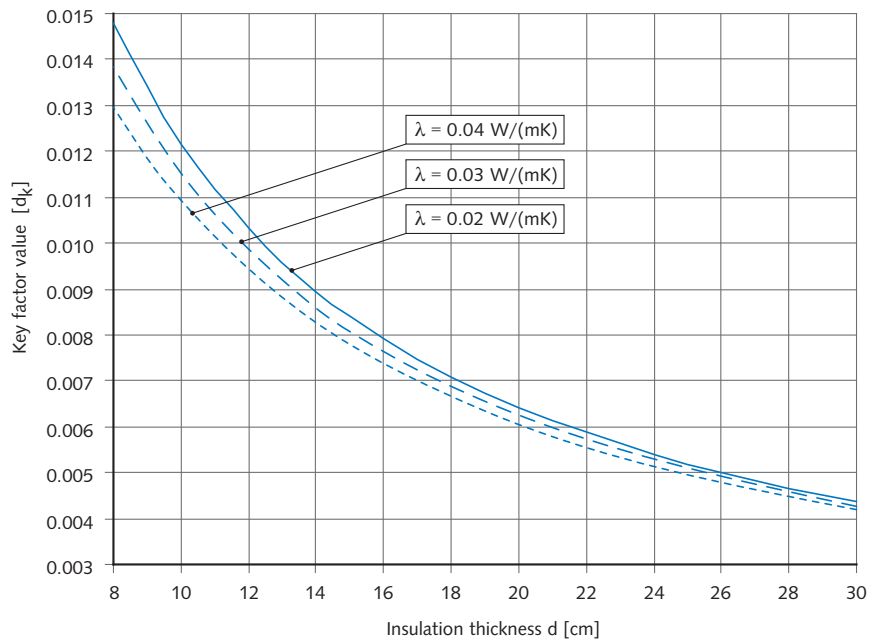

An Excel-tool is available to calculate the heat transmission coefficient in the pre-planning stage. The tool can be downloaded from www.halfen.com

Insulation material	
d [cm]	
λ [W/(mK)]	
d_k [-]	

Calculation; heat transmission coefficient adjustment-factor				
Type FPA / type spacer bolt	A_{eq}	$\chi_i = A_{eq} \times d_k$	n_a number of FPA / of spacer bolts per m ²	$\Delta U_i = \chi_i \times n_a$
Heat transmission coefficient factor $\Sigma \Delta U_i = c_i \times n_a$				

HALFEN CONCRETE FAÇADE ANCHOR SYSTEMS

Tender Specification

HALFEN FPA-3 Precast panel anchors

HALFEN FPA-3 Precast panel anchors or similar with rear anchorage through in-situ concrete element.

Building authority certified anchor; made of A4/L4 = stainless steel, corrosion resistance class (CRC) III according to Z-30.3-6 / EN 1993-1-4 for vertical load distribution of suspended pre-fabricated reinforced elements.

Slab size $W \times H \times D = \dots$ [cm]

Structural wall thickness $d = \dots$ [cm]

Wall cavity $b = \dots$ [cm]

Subject to alternative requirements resulting from subsequent static calculation.

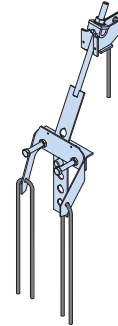

HALFEN FPA-5 Precast panel anchors

HALFEN FPA-5 Precast panel anchors or similar HALFEN Cast-in channels or tensile zone suitable dowels on a shell construction.

Building authority certified anchor; made of A4/L4 = stainless steel, corrosion resistance class (CRC) III according to Z-30.3-6 / EN 1993-1-4 for vertical load distribution of suspended precast reinforced elements.

Slab size $W \times H \times D = \dots$ [cm]

Structural wall thickness $d = \dots$ [cm]

Wall cavity $b = \dots$ [cm]

Subject to alternative requirements resulting from subsequent static calculation.

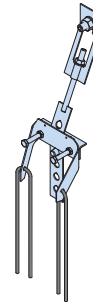

HALFEN DS 13 Spacer bolt

HALFEN DS 13 Spacer bolts or similar to support the façade element.

Type tested anchor/officially approved; made of A4/L4 = stainless steel, corrosion resistance class (CRC) III according to Z-30.3-6 / EN 1993-1-4 for horizontal load distribution (compression) of suspended precast reinforced concrete elements.

Slab size $W \times H \times D = \dots$ [cm]

Wall cavity $b = \dots$ [cm]

Thread size $M \dots$ [cm]

Subject to alternative requirements resulting from subsequent static calculation.

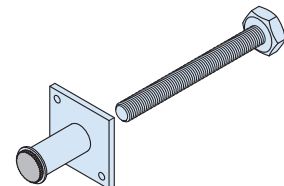

HALFEN LD Wind anchor

HALFEN LD Wind anchor; load group 2.0 or similar for suction restraint of façade elements, anchor made of A4/L4 = stainless steel, corrosion resistance class (CRC) III according to Z-30.3-6 / EN 1993-1-4 for horizontal load distribution (tensile and compression) of suspended precast reinforced concrete elements in combination with HALFEN DS 13 Spacer bolts.

Wall cavity $b = \dots$ [cm]

Structural wall thickness $d = \dots$ [cm]

Subject to alternative requirements resulting from subsequent static calculation.

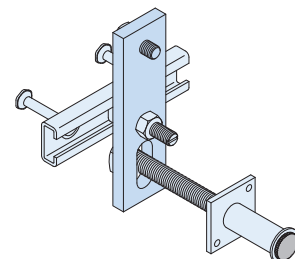

HALFEN CONCRETE FAÇADE ANCHOR SYSTEMS

Tender Specification

HALFEN HFV Dowel restraints in plastic

HALFEN HFV Dowel restraints .../.../... (e.g. 5/3/9) load group 2.5 with sleeve in plastic or similar to support the façade slab from below.

Upper and lower part: plastic; Pin made of A4/L4 = stainless steel, corrosion resistance class (CRC) III according to Z-30.3-6 / EN 1993-1-4 for horizontal load distribution (tensile and compression) of suspended precast reinforced concrete elements

Slab thickness $D = \dots$ [cm]

Optional spiral reinforcement for dowel restraints HFV B - ...

Subject to alternative requirements resulting from subsequent static calculation.

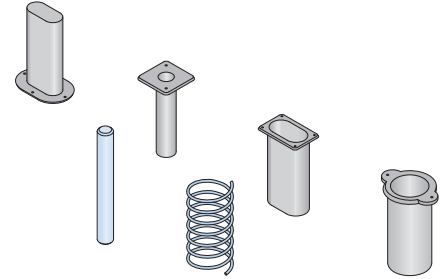

HALFEN HFV Dowel restraints in stainless steel

HALFEN HFV Dowel restraints .../.../... (e.g. 8/3/4) load group 2.5 with welded tie-back reinforcement; 100% stainless steel or similar for the lower support of the façade slab.

Complete set (upper- and lower-part- plus dowel) made of A4/L4 = stainless steel, corrosion resistance class (CRC) III according to Z-30.3-6 / EN 1993-1-4 for horizontal load distribution (tensile and compression) of suspended precast reinforced concrete elements.

Slab thickness $D = \dots$ [cm]

Subject to alternative requirements resulting from subsequent static calculation.

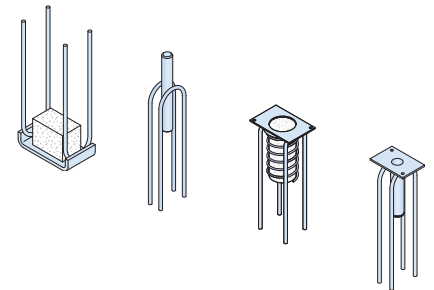

HALFEN BRA-N L4 Parapet anchor (standard version)

HALFEN BRA-N L4 Parapet anchor incl. BRA-M1-... Installation set or similar for fitting to precast reinforced concrete.

Type tested anchor made of A4/L4 = stainless steel, corrosion resistance class (CRC) III according to Z-30.3-6 / EN 1993-1-4 in standard design.

Load bearing (1 to 8) = ...

Profile length = ... [cm]

Wall clearance $b = \dots$ [cm]

Subject to alternative requirements resulting from subsequent static calculation.

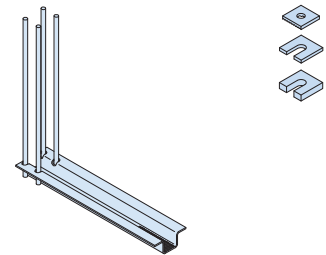

HALFEN BRA-NJ L4 Parapet anchor (adjustable)

HALFEN BRA-NJ L4 Parapet anchor incl. BRA-M1-... and BRA-M2-... Installation sets or similar for fitting to precast reinforced concrete.

Type tested adjustable anchor made of A4/L4 = stainless steel, corrosion resistance class (CRC) III according to Z-30.3-6 / EN 1993-1-4 in standard design.

Load bearing (1 to 8) = ...

Profile length = ... [cm]

Wall clearance $b = \dots$ [cm]

Subject to alternative requirements resulting from subsequent static calculation.

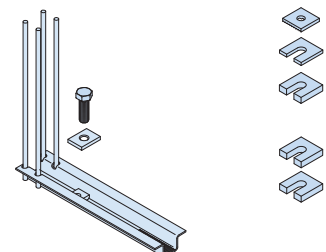

Further tender specifications can be downloaded from our homepage:
www.halfen.com

HALFEN CONCRETE FAÇADE ANCHOR SYSTEMS

HALFEN Façade Fixing Systems

Façade fixing systems for concrete façades

HALFEN SP Sandwich panel anchors

Sandwich panel elements combine the static characteristics of a concrete wall with the functional and aesthetic character required for exterior walls. Building authority approved HALFEN Sandwich panel anchors (SP-SPA, SP-FA and SP-MVA) are used to connect the facing slab to the load bearing inner slab.

The insulation is penetrated only by anchors with minimal cross-sections, which result in comparatively minor thermal bridging.

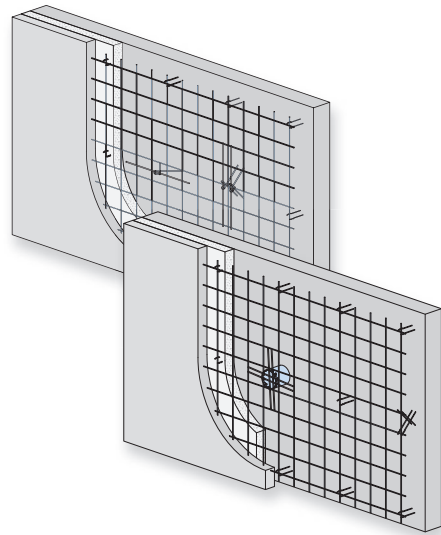

Concrete pre-cast system – catalogues on the internet

The catalogues for our concrete pre-cast systems can be found at www.halfen.com/Downloads/Brochures or simply scan the code and then select the required document.

Transport anchor systems for Concrete façades

HD-Anchors

HD-anchors are more compact and slender than conventional standard anchors. The reduced diameters of the sleeve make them flexible in application and particularly suitable for use in thin façade panels.

The integrated thread protector protects against impurities and from water penetration.

The recess fillers, which are made of the same concrete as the cast elements, ensure that the anchors are no longer visible after final transport.

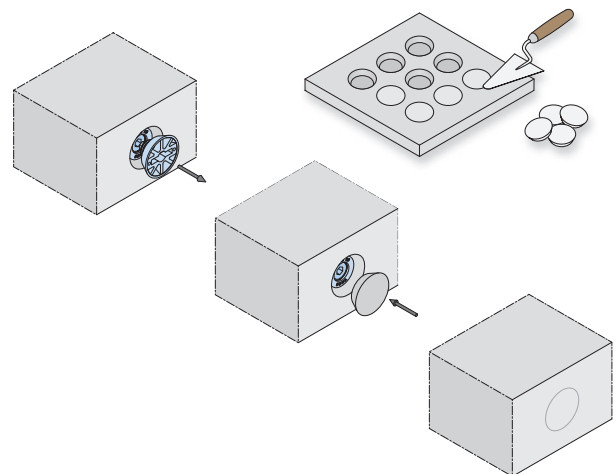

For further information please see our HD-Transport anchor systems catalogue.



Leviat®

Innovative engineered products
and construction solutions that
allow the industry to build safer,
stronger and faster.



Contact Leviat worldwide

Australia

Unit A, 1 Heinrich Close,
Eastern Creek, Sydney, NSW 2766
Tel: +61 - 2 8808 3100
Email: info.au@leviat.com

Austria

Leonard-Bernstein-Str. 10
Saturn Tower, 1220 Wien
Tel: +43 - 1 - 259 6770
Email: info.at@leviat.com

Belgium

Industrielaan 2
1740 Ternat
Tel: +32 - 2 - 582 29 45
Email: info.be@leviat.com

China

Room 601 Tower D,
Vantone Centre
No. A6 Chao Yang Men Wai Street
Chaoyang District
Beijing P.R. China 100020
Tel: +86 - 10 5907 3200
Email: info.cn@leviat.com

Czech Republic

Pekařská 695/10a
155 00 Praha 5
Tel: +420 - 311 - 690 060
Email: info.cz@leviat.com

Finland

Vädursgatan 5
412 50 Göteborg / Sweden
Tel: +358 (0)10 6338781
Email: info.fi@leviat.com

France

6, Rue de Cabanis
31240 L'Union
Tel: +33 (0)5 34 25 54 82
Email: info.fr@leviat.com

Germany

Liebigstrasse 14
40764 Langenfeld
Tel: +49 - 2173 - 970 - 0
Email: info.de@leviat.com

India

Unit S4, 902, A Wing,
Lodha iThink Techno Campus Building,
Panchpakhadi, Pokharan Road 2,
Thane, 400606
Tel: +91-022 695 33700
Email: info.in@leviat.com

Italy

Via F.lli Bronzetti 28
24124 Bergamo
Tel: +39 - 035 - 0760711
Email: info.it@leviat.com

Malaysia

28 Jalan Anggerik Mokara 31/59
Kota Kemuning,
40460 Shah Alam Selangor
Tel: +603 - 5122 4182
Email: info.my@leviat.com

Netherlands

Oostermaat 3
7623 CS Borne
Tel: +31 - 74 - 267 14 49
Email: info.nl@leviat.com

New Zealand

246D James Fletcher Drive, Otahuhu,
Auckland 2024
Tel: +64 - 9 276 2236
Email: info.nz@leviat.com

Philippines

27F Office A, Podium West Tower,
12 ADB Avenue, Ortigas Center
Mandaluyong City, 1550
Tel: +63 - 2 7957 6381
Email: info.ph@leviat.com

Poland

Ul. Obornicka 287
60-691 Poznań
Tel: +48 - 61 - 622 14 14
Email: info.pl@leviat.com

Singapore

10 Benoi Sector,
Singapore 629845
Tel: +65 - 6266 6802
Email: info.sg@leviat.com

Spain

Polígono Industrial Santa Ana
c/ Ignacio Zuloaga, 20
28522 Rivas-Vaciamadrid
Tel: +34 - 91 632 18 40
Email: info.es@leviat.com

Sweden

Vädursgatan 5
412 50 Göteborg
Tel: +46 - 31 - 98 58 00
Email: info.se@leviat.com

Switzerland

Grenzstrasse 24
3250 Lyss
Tel: +41 (0)800 22 66 00
Email: info.ch@leviat.com

United Arab Emirates

RA08 TB02, PO Box 17225
JAFZA, Jebel Ali, Dubai
Tel: +971 (0)4 883 4346
Email: info.ae@leviat.com

United Kingdom

President Way,
President Park,
Sheffield S4 7UR
Tel: +44 - 114 275 5224
Email: info.uk@leviat.com

USA / Canada

6467 S Falkenburg Road
Riverview, FL 33578
Tel: (800) 423-9140
Email: info.us@leviat.us

For countries not listed

Email: info@leviat.com

Notes regarding this document

© Protected by copyright. The information in this publication is based on state-of-the-art technology at the time of publication. In every case, project working details should be entrusted to appropriately qualified and experienced persons. Leviat shall not accept liability for the accuracy of the information in this document or for any printing errors. We reserve the right to make technical and design changes at any time. With a policy of continuous product development, Leviat reserves the right to modify product design and specification at any time.

Leviat®

Imagine. Model. Make.

Leviat.com