

HALFEN HZA-PS POWER SOLUTION

Technical Product Information



NEW

Seismic C1/ C2 assessment
report and ETA-17/0728
for HZA-PS 53/34

Leviat

We imagine, model and make engineered products and innovative construction solutions that help turn architectural visions into reality and enable our construction partners to build better, safer, stronger and faster.

Leviat is a world leader in connecting, fixing, lifting and anchoring technology.

From the build of new schools, hospitals, homes and infrastructure, to the repair and maintenance of heritage structures, our engineering skills are making a difference around the world.

We provide technical design assistance at every stage of a project, from initial planning to installation and beyond.

Our technical support services range from simple product selection through to the development of a fully customised project-specific design solution.

Every promise we make locally, has the commitment and dedication of our global team behind it. We employ almost 3,000 people at 60 locations across North America, Europe and Asia-Pacific, providing an agile and responsive service worldwide.





>3,000
People

60+
Locations

~20
Countries

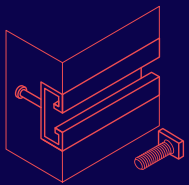

Anchoring & Fixing

Systems for fixing secondary fixtures to concrete, including anchor channels, bolts and inserts; also tension rod systems for roofs and canopies.

- Cast-in Channels, T-Bolts & Accessories
- Threaded Inserts
- Rod Systems
- Attachment Points
- Post Installed Anchor Systems

Other areas of expertise:

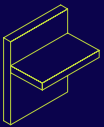

Structural Connections

Systems to form robust, efficient connections, and continuity of concrete reinforcement as necessary, between walls, slabs, columns, beams and balconies, providing structural integrity as well as enhanced thermal and acoustic performance.

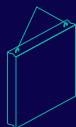

Lifting & Bracing

Systems for the safe and efficient transportation, lifting and temporary bracing of cast concrete elements and tilt-up panels before permanent structural connections are made.

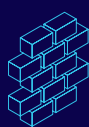

Façade Support & Restraint

Systems for the safe and thermally-efficient fixing of the external building envelope, including brick and natural stone, insulated sandwich panels, curtain walling and suspended concrete façades, and also the repair and strengthening of existing masonry installations.



Formwork & Site Accessories

Non-structural accessories that complement our engineered solutions and help keep your construction environment operating safely and efficiently, including moulds for casting standard and special concrete elements and construction essentials such as reinforcing bar spacers.

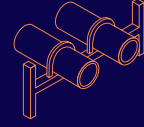

Industrial Technology

Mounting channels, pipe clamps and other versatile framing systems that provide safe fixing in a wide range of industrial applications.

Leviat product ranges:

Ancon | Aschwanden | Connolly | Halfen | Helifix | Isedio | Meadow Burke | Modersohn | Moment | Plaka | Scaldex | Thermomass

HALFEN HZA-PS POWER SOLUTION

HALFEN Cast-in Channels for Power Plants

Standard application

HALFEN HTA-CE and HZA Channels are officially approved and recommended for applications in normal concrete projects; office buildings, schools, industrial buildings or in non-critical areas of nuclear power plants.

In these applications the maximum crack width in the concrete is 0.3 mm. For more information please see the Technical Product Information for HALFEN Cast-in channels.

Free download at:

www.halfen.com/brochures/construction/fixing systems/HTA Cast-in channels

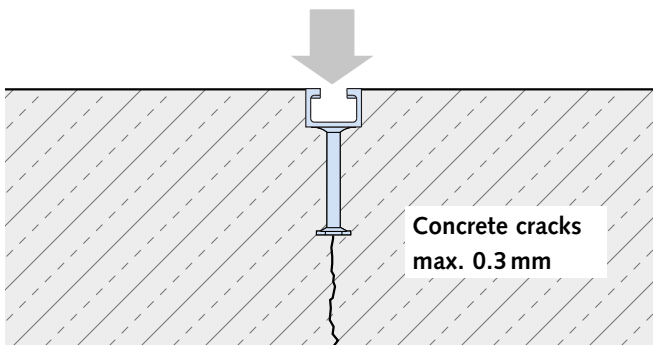
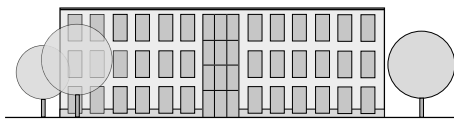

HALFEN HTA-CE and HZA Cast-in channels

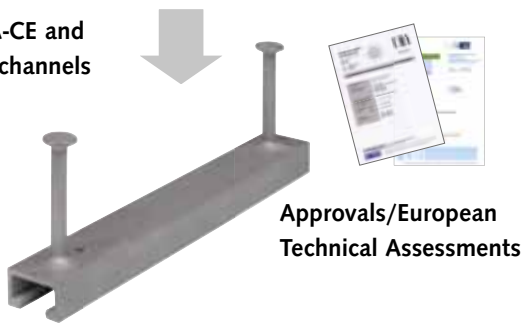

Safety relevant applications

Higher safety requirements for exterior (EVA) or interior (EVI) impact loads must be considered in safety relevant areas e.g. in nuclear power plants or other nuclear facilities. The suitability of the HZA-PS Channels for extraordinary impact loads has been verified in simulated application tests. All these tests were done in concrete with opening and closing cracks varying from 1.0 mm up to 1.5 mm. The results are summarized in evaluation report 09.05.18-E (see also pages 8 and 9).

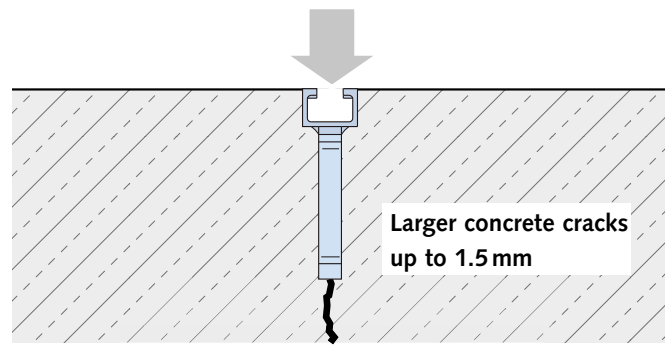
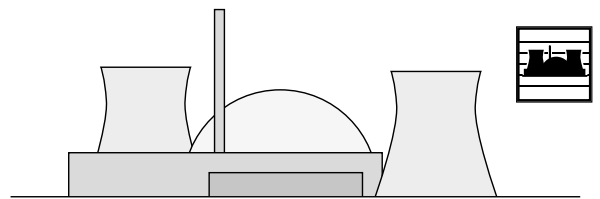

HALFEN HZA-PS Cast-in channel



Nuclear power plant under construction

HALFEN HZA-PS POWER SOLUTION

HALFEN Cast-in Channels for Power Plants

Approvals

HALFEN Cast-in channels are available in hot-dip galvanized or in stainless steel. Building authority approved by the German Institute of Construction Engineering (DIBt, *Deutsches Institut für Bautechnik*).

Cast-in channels are embedded in the concrete, flush with the surface. HALFEN T-bolts or serrated t-bolts, nuts and washers are used to reliably attach structural elements to the channels.

HTA-CE: ETA-09/0339
 HZA 41/22: App. no. Z-21.4-145
 HZA Dynagrip: App. no. Z-21.4-1691

HZA-PS 53/34: ETA-17/0728



Evaluation Report

HALFEN HZA-PS Cast-in channels are suitable for applications in safety relevant areas of nuclear power plants and other nuclear facilities.

HALFEN HZA-PS Cast-in channels meet the high requirements for extraordinary impacts from external (EVA) and internal (EVI) loads e.g. earthquakes, plane crash or explosions.

evaluated by the:



Faculty for Architecture and Building Engineering
 Concrete structures – Connection technology

HZA-PS 53/34; HZA-PS 38/23;
 HZA-PS 29/20
 Evaluation Report
 Technical University
 of Dortmund 09.05.18-E



HZA-PS 53/34
 Seismic C1/C2 assessment
 report, Technical University
 of Kaiserslautern, see page 5



Fire Protection

HALFEN HTA and HZA Cast-in channels, in combination with HALFEN Channel bolts, have been certified for use in fire-exposed structural elements.

The anchor channels have a fire rating of up to 120 minutes for concrete structures if installed according to the approvals stated above.



Sustainability

An EPD® (Environmental Product Declaration) provides transparent and comparable ecological data which helps to evaluate the sustainability of a building.

The new HPD (Health Product Declaration) for hot-dip galvanized HALFEN Cast-in channels helps to achieve additional points in the Leed-v4-system.

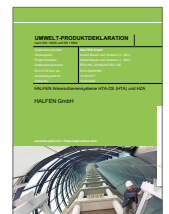

BIM

We already have considerable experience as a BIM partner and we successfully completed various projects using the BIM methodology.

Examples of previous projects developed using BIM can be found at www.halfen.com/Service/BIM/BIMreferences.

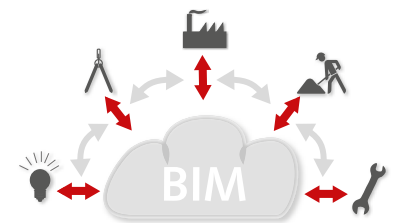

Quality

Our subsidiaries are Quality Management certified according to ISO 9001:2015, Certificate no. 202384-2016-AQ-GER-DAKKS.



Cert.-no. QS-281 HH



The approvals can be found at:
www.halfen.com/downloads/brochures

HALFEN HZA-PS POWER SOLUTION

HALFEN Cast-in Channels for Power Plants



The anchor head

The wide, almost parallel anchor head is a positively interlock connection and results in very effective load transmission due to the low bearing pressure under the head. Furthermore, there is an additional enormous advantage

when used in concrete designed for possible wide cracks. With the minor movement of the anchorage system during opening and closing of cracks, a reliable fixing with low deformation can be guaranteed.

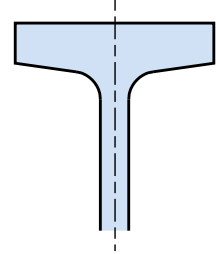

Anchoring depth

Deep anchorage guarantees high load capacity and compensates for weakness in the concrete caused by larger cracks. Concrete elements designed for safety relevant areas are generally densely reinforced. The increase in anchorage depth helps to ensure an

ideal load distribution into the reinforcement. Simultaneously the channels (maximum height is 44 mm) are easily installed in the standard concrete cover which is about 45–60 mm.

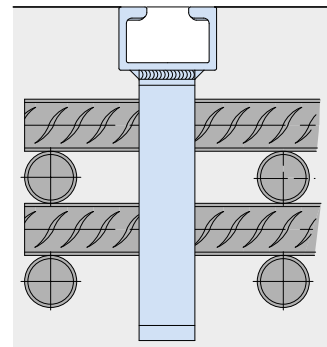

Channel profile

The manufacturing process for hot-rolled channels has allowed a more efficient design of the channel cross section. This results in thicker channel lips which are stronger than the channel backs or sides. This feature prevents lip deformation while providing reliable and efficient transfer of impact loads through the channel

profile into the concrete structure. The hot-roll process also prevents deformation over the channel length caused during production and improving the connection of components. Dynamic loads can also be better transmitted as the hot-rolled material has low internal stresses.

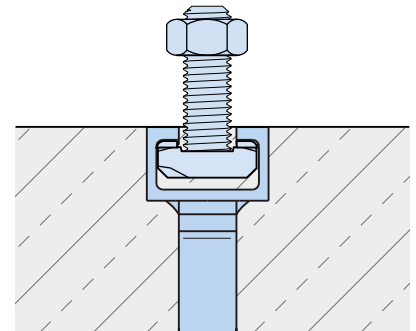

Serrated channel lips

A hard-wearing inner serration is formed in the channel lip material during the rolling process. The serrated HALFEN Channel bolts engage with the matching 3.0 mm pitch of the channel serration allowing non-slip, reliable transfer of loads in the longitudinal direction of the channel.

The serrated anchor channels are very beneficial for application in seismic zones or other load cases applications; explosion collision loads or similar. To achieve full load capacities in the longitudinal direction of the anchor channels the specified torque has to be observed (see installation instructions).

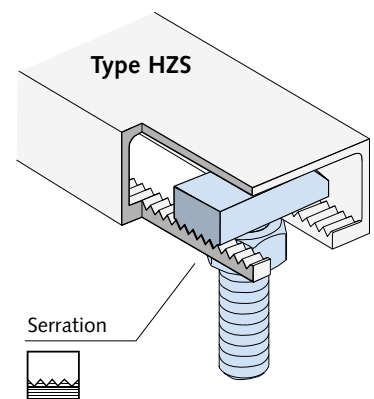

HALFEN HZA-PS POWER SOLUTION

HALFEN Cast-in Channels for Power Plants



The anchor foot

The anchor foot is welded on all four edges to the back of the channel. This ensures efficient and even transfer of static loads and critical dynamic loads from the channel into the anchor.

The extensive weld length is an additional safety feature. This is improved on with regular, selective ultimate load tests of welded anchors in our quality assurance programme.



HALFEN Channel bolts (serrated)

Without exception all HZS Channel bolts for the HZA-PS Systems are only available in high strength grade 8.8. This ensures reliable transfer of loads into the channel, even if an additional moment acts on the bolt.

A specified torque is applied to ensure a positive lock between the bolt and the serration in the channel. The specified torque is critical to ensure full load capacity in the longitudinal channel direction. It is important that the torques specified in the installation instructions are observed.



Seismic performance categories C1/C2 assessment report for HZA-PS 53/34

The seismic assessment and expert reports for the HALFEN anchor channel HZA-PS 53/34 cover the technical specifications of the AFCEM code RCC-CW, which corresponds to the demands of ETAG 001 Annex E (replaced by TR 049). The report provides characteristic seismic resistance

$R_{k,eq,steel}^0$ for each direction and for performance category C1 and C2.

HALFEN Anchor Channels HZA-PS 53/34 fulfil the high requirements of seismic performance category C2 with excellent ductile behaviour, no anchor failure and low displacements.

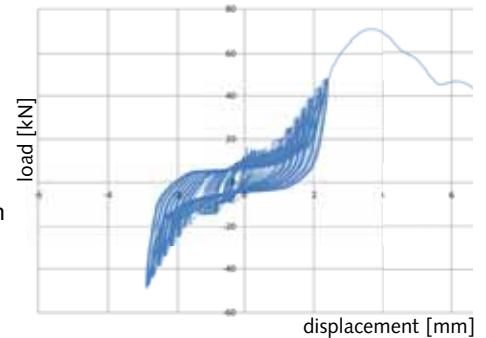

Quality

Our production facilities are EN ISO 9001 certified. The certification requires regular maintenance of all machines and continual inspections of all processes at the facilities. The production facilities are certified for welding processes according to international standard EN ISO 3834-2 and EN 1090. All incoming material must be certified acc. to EN 10204.

Chemical, mechanical and geometric material properties are also checked. All products are subject to random quality testing during production which includes ultimate tensile testing. The zinc layer is regularly checked for thickness to ensure good quality corrosion protection.



Certification

According to DIN EN 10204 the following documents may be requested:

Acceptance certificates based on non-specific test (production 2.1 certificate and production 2.2 certificate [a more detailed description]) and acceptance certificates based on specific tests on

the delivered product (inspection 3.1 certificate).

The customer **can** request a 3.1 certificate when placing an order.

A 3.1 certificate issued by a manufacturer confirms the test results of the delivered products fulfil the specified requirements.



HALFEN HZA-PS POWER SOLUTION

HALFEN Cast-in Channels for Power Plants

With more than 90 years of experience we became a world leader in providing adjustable anchoring systems.

HALFEN Cold-rolled cast-in channels fulfil all basic requirements for an adjustable, user-friendly and reliable anchoring system. The product family includes hot-rolled channels with optimal characteristics for reliable transfer of dynamic loads. The hot-rolled serrated HALFEN Channels are also suitable for transfer of loads in its longitudinal direction.

A logical complement to the serrated hot rolled channel range, the HZA-PS product range allows application in safety relevant areas of nuclear power stations and facilities.

A dedicated test-programme carried out at the Technical University of Dortmund/Germany confirms suitability of HALFEN Channels HZA-PS 53/34, HZA-PS 38/23 and HZA-PS 29/20 for exceptional loads.

This additional research and the tests assume extreme interior and exterior load-effects caused by earthquakes, explosions and plane impacts.

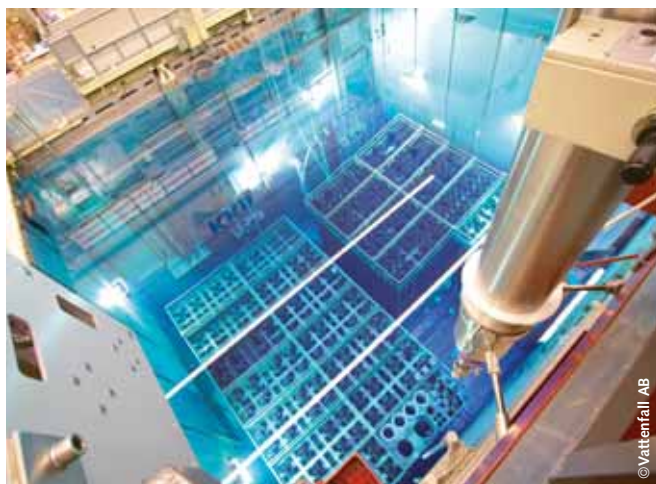
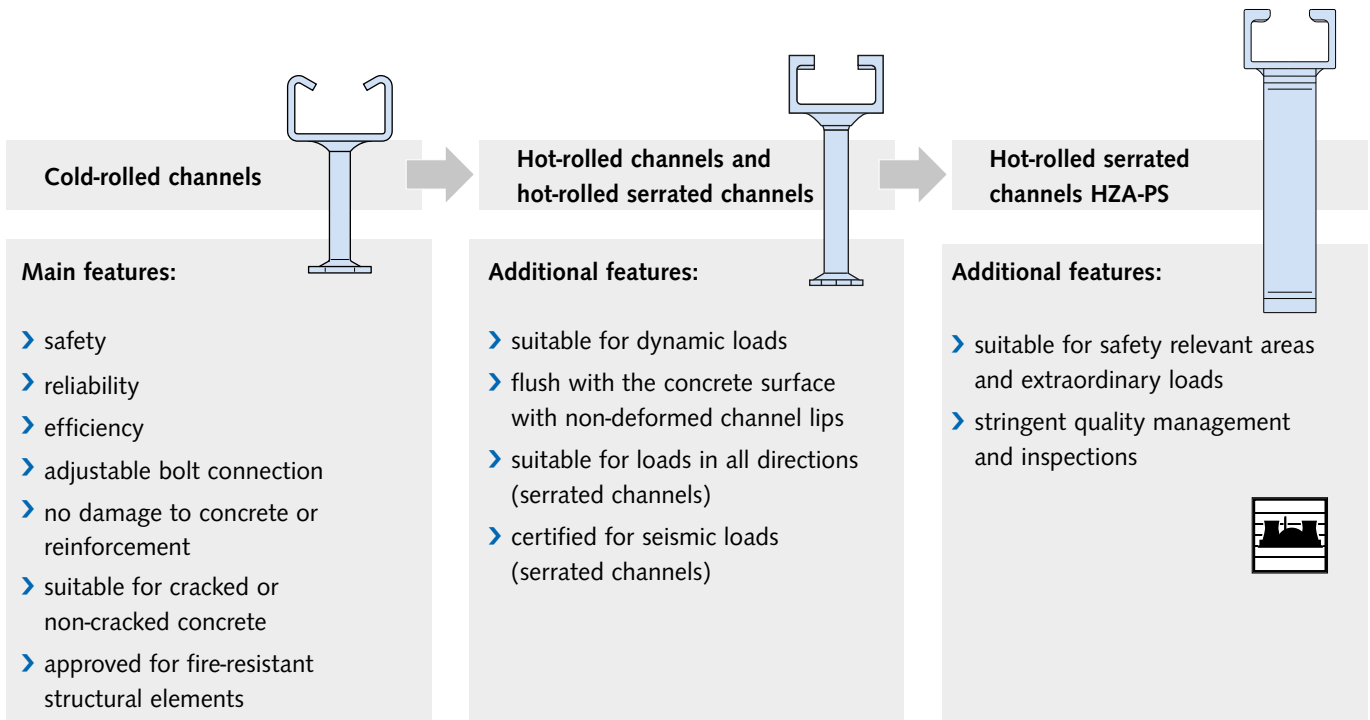

Fuel element cooling



Turbine block in a nuclear power plant

HALFEN HZA-PS POWER SOLUTION

HALFEN Cast-in Channels for Power Plants

HZA-PS Cast-in channels

HZA-PS 29/20

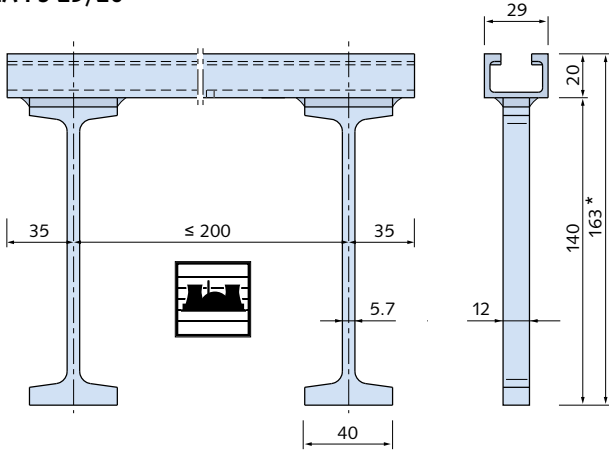

HZA-PS 38/23

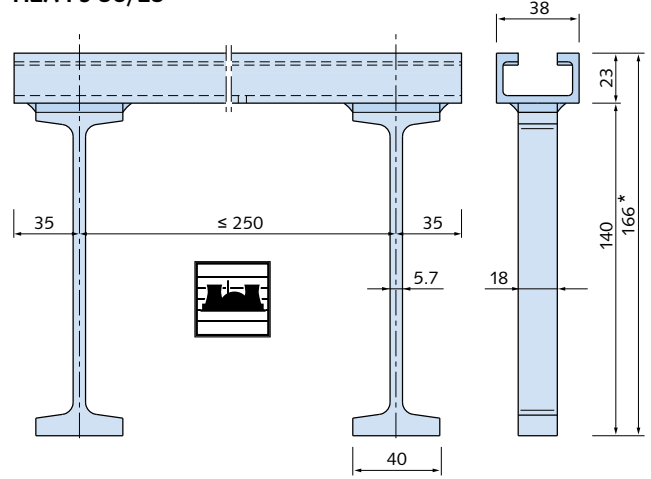

HZA-PS 53/34

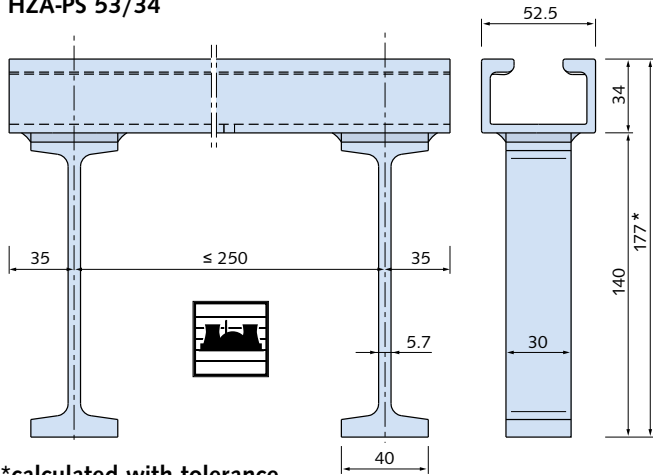

HZA-PS 64/44

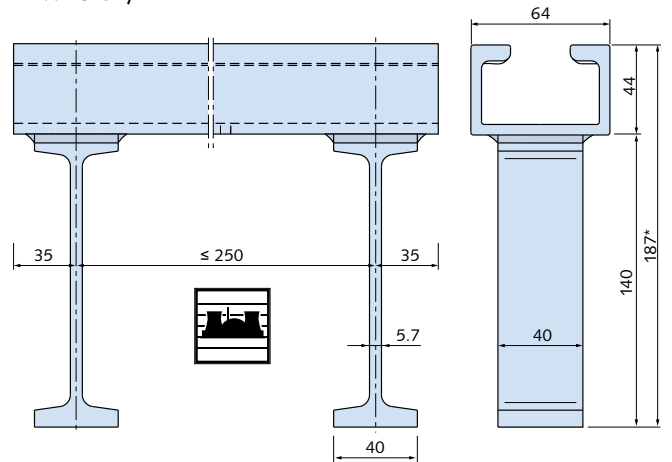

*calculated with tolerance

Available lengths (made to order) and anchor spacing

HZA-PS 38/23, 53/34, 64/44 – Standard lengths			
Length [mm] / Number of anchors			
200 / 2	350 / 3	550 / 3	800 / 4
1050 / 5	3030 / 13	6070 / 25	

HZA-PS 29/20 – Standard lengths			
Length [mm] / Number of anchors			
200 / 2	350 / 3	550 / 4	800 / 5
1050 / 6	3030 / 16	6070 / 31	

HZA-PS 38/23, 53/34, 64/44 – Fixed standard lengths			
Length [mm] / Number of anchors			
-	1300 / 6	1550 / 7	1800 / 8
2050 / 9	2300 / 10	2550 / 11	2800 / 12
-	3300 / 14	3550 / 15	3800 / 16
4050 / 17	4300 / 18	4550 / 19	4800 / 20
5050 / 21	5300 / 22	5550 / 23	5800 / 24

HZA-PS 29/20 – Fixed standard lengths			
Length [mm] / Number of anchors			
1250 / 7	1450 / 8	1650 / 9	1850 / 10
2050 / 11	2250 / 12	2450 / 13	2650 / 14
2850 / 15	-	3250 / 17	3450 / 18
3650 / 19	3850 / 20	4050 / 21	4250 / 22
4450 / 23	4650 / 24	4850 / 25	5050 / 26
5250 / 27	5450 / 28	5650 / 29	5850 / 30

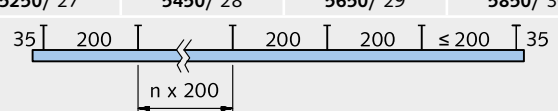
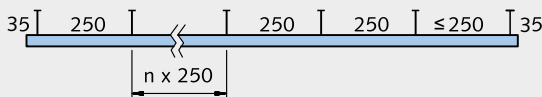

HALFEN HZA-PS POWER SOLUTION

HALFEN Cast-in Channels for Power Plants

Various specifications taken from different certifications and categories apply in nuclear power plants and nuclear facilities (see DIN 25449):

Category A3: Load cases which may occur only once during the lifetime of the facility:

- earthquake
- plane crash
- exterior explosion
- interior explosion
- differential pressure
- supporting forces etc.

Category A2: Load cases which are likely to occur less than ten times during the lifetime of the facility.

Category A1: Load cases which are likely to occur more than ten times during the lifetime of the facility.

As a result of the higher demands of category A3 and A2 wider concrete cracks must be considered. Therefore, the behaviour of the anchoring system is examined in additional suitability tests with larger crack widths.

The existing guidelines set by the (DIBT) German Institute of Building Technology for use of post installed anchors in nuclear power plants was the basis used for specification of the additional tests.

Examples of tests include:

1. Pull-out test; the anchor was tested in a 1.0 mm wide concrete crack

2. Pull-out test; the anchor was tested in a 1.5 mm wide concrete crack

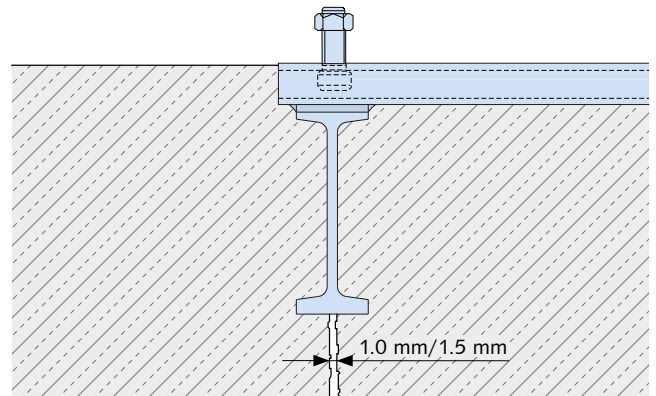

1.0 and 1.5 mm concrete cracks in the location of the anchor

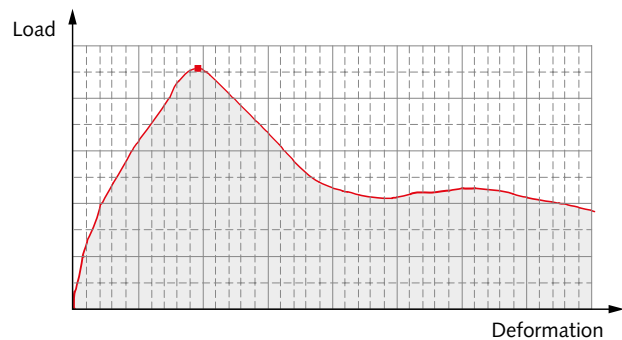

Load-deformation diagram of a pull-out test showing the constant load increase with low deformation until maximum load is achieved.



Test setup; pull-out test

HALFEN HZA-PS POWER SOLUTION

HALFEN Cast-in Channels for Power Plants

3. Performance test in an opening and closing concrete crack

For this purpose, 10 oscillations were applied with a frequency of 0.2 Hz; the concrete crack varying between 1.0 and 1.5 mm, while the cast-in channel was subjected to a constant tension load. A pull-out test was subsequently carried out in the widest concrete crack of 1.5 mm.

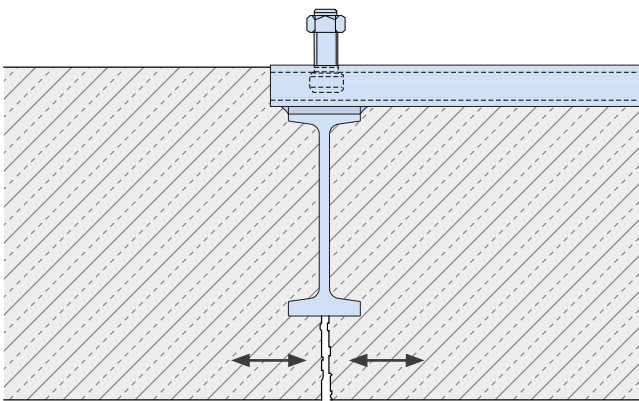

Anchor position directly in an opening and closing concrete crack.

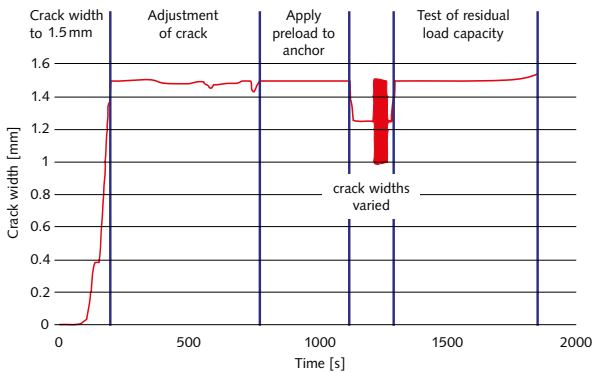

Chronological test procedure

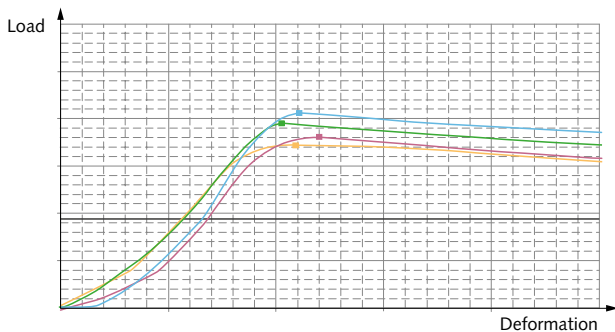

Load-displacement diagram: shows ductile behaviour during the final pull-out test.

4. Cyclic load change in a wide concrete crack

In this test, cracks in the concrete were opened to 1.5 mm and a tension load applied to the cast-in channel. The load was then completely removed from the cast-in channel. In this test 15 load cycles with a frequency $F < 1$ Hz were applied. A pull-out test was subsequently carried out in the widest (1.5 mm) concrete crack.

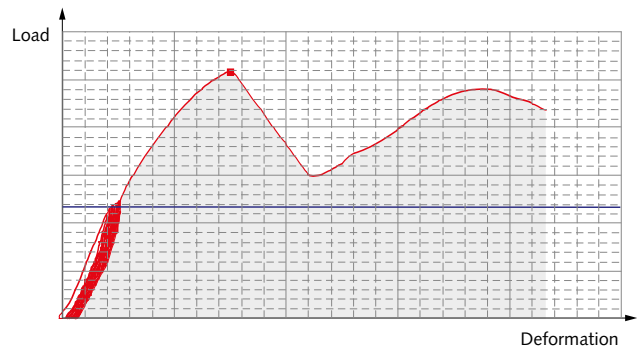

Load-displacement diagram - even after the cyclic load test the final pull-out test shows a steady increase with only low deformation.



Test setup for cyclic load test

HALFEN HZA-PS POWER SOLUTION

HALFEN Cast-in Channels for Power Plants

HZS bolts – available lengths

HZS 29/20 **HZS 38/23** **HZS 53/34** **HZS 64/44**
M12 **M16** **M20** **M24**

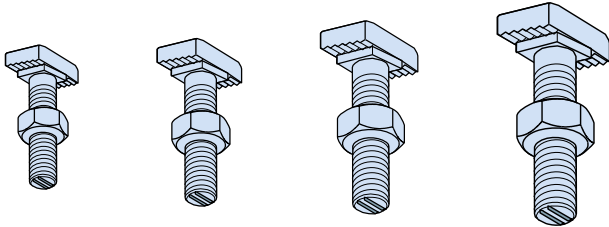

HZS T-Bolt lengths		
Bolt type/ channel profile	Bolt diameter (mm)	Grade 8.8 Bolt length (mm)
HZS 64/44	M24	80, 150
HZS 53/34	M20	65, 100
HZS 38/23	M16	40, 60, 80
HZS 29/20	M12	60, 80

For bolts in other lengths and diameters please contact us (→ see page 19).

Product identification

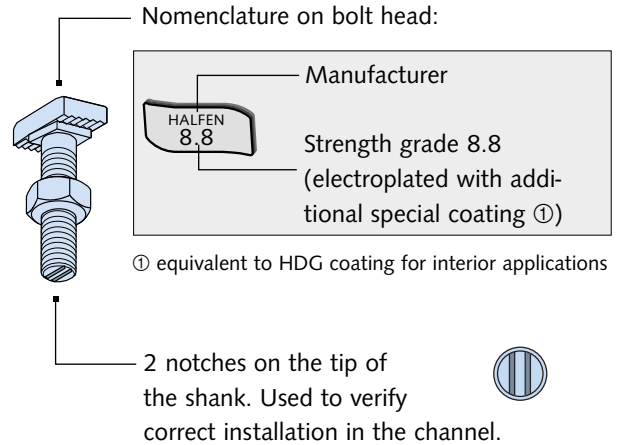

Example order for bolts:

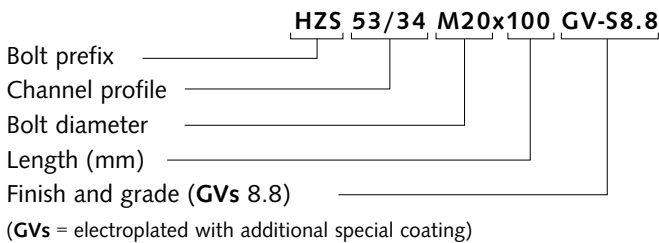

Example order for channels:

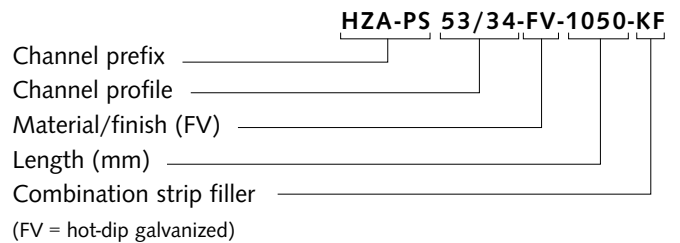

Tender specifications- Examples

1. HALFEN Cast-in channels

1.1 HALFEN HZA-PS Channel type – Power Solution

HALFEN HZA-PS Cast-in channel _____, hot-dip galvanized (FV) with strip filler (KF), suitable for adjustable connections to concrete in safety relevant areas of nuclear plants or other nuclear installations, channel length _____ mm, design resistance $F_{Rd} =$ _____ kN in all directions, up to _____ kN dynamic loading, delivery and installation according to the installation instructions.

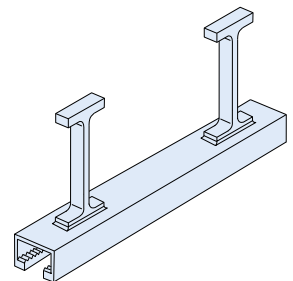

2. HALFEN Bolts

2.1 HALFEN Bolts type HZS

HALFEN HZS serrated bolt _____ suitable for the corresponding HALFEN HZA-PS Cast-in channel, electroplated with special coating, including nut, delivery and installation according to the installation instructions.

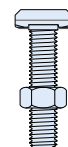

HALFEN HZA-PS POWER SOLUTION

HALFEN Cast-in Channels for Power Plants

Load capacities, HZA-PS 53/34 acc. to ETA-17/0728



The HZA-PS 53/34 (ETA-17/0728) design is based on EOTA TR 047 (EN 1992-4).

Verification will account for specific boundary conditions and differentiates between steel and concrete failure modes.

Profile load capacity* HZA-PS 53/34		
HZA-PS 53/34 acc. to ETA-17/0728		
$N_{Rd,s,l}^0$ [kN]	43.7	* Concrete load capacity has to be verified for each individual case (taking the geometric boundary conditions into account).
$V_{Rd,s,l,y}^0$ [kN]	43.7	
$V_{Rd,s,l,x}$ [kN]/ γ_{inst}	27.3	$N_{Rd,s,l}^0$ = channel lip load capacity (tension)
$M_{Rd,s,flex}$ [Nm]	3538	$V_{Rd,s,l,y}^0$ = channel lip load capacity (shear perpendicular) $V_{Rd,s,l,x}$ = channel lip load capacity (shear longitudinal)

Seismic performance categories C1 and C2



HALFEN HZA-PS 53/34 Cast-in channels have been tested under simulated seismic tension and shear loads according to EOTA TR 049 for seismic performance categories C1 and C2. The assessment of the test results was done by the Technical University of Kaiserslautern and can be found in the test report. Available on request.

The Support team is available to help with planning. Contact Information can be found at the back of the catalogue or go to: www.halfen.com

Load capacities of HZA-PS according to Z-21.4-1691



Loads

All the values shown are design resistance capacities and should therefore be compared against fully factored loads.

e.g. $F_{Ed} = \gamma_G G_k + \gamma_Q Q_k$

where:

- γ_G = partial factor for permanent loads
- G_k = characteristic value of permanent loads (dead load)
- γ_Q = partial factor for variable loads
- Q_k = characteristic value of variable loads (imposed or live load)

Design steel resistance F_{Rd}		s = anchor spacing see page 7					
F_{Rd} with simultaneous loading in all directions	<div style="border: 1px solid black; padding: 5px;"> To check: ① (A) $F_{Ed} = \sqrt{N_{Ed}^2 + V_{xEd}^2 + V_{yEd}^2} \leq F_{Rd}$ (B) $V_{x,Ed} \leq 0.8 \times F_{Rd}$ (single load) </div>	Single loads		Load pairs			
		F_{Rd} [kN]	F_{Rd} [kN] ②	$p_i = 50$	$p_i = 100$	$p_i = 150$	$p_i = 200$
HZA-PS profile ①	64/44	37.8	-	23.6	27.0	31.5	37.8
	53/34	30.8	-	19.25	22.0	25.7	30.8
	38/23	16.8	9.4	10.5	12.0	14.0	16.8
	29/20	11.2	6.3	7.5	9.0	11.2	11.2

① Check B is only necessary if there are 2 or more bolts connecting **one** component.

② Intermediate values may be linearly interpolated.

Sufficient concrete resistances are provided if the boundary conditions are in accordance with the approval Z-21.4-1691 and the Technical Product Information for HALFEN Cast-in channels.

Extraordinary impact loads from external (EVA) or internal (EVI) forces are given in the Evaluation Report TU Dortmund.

Available on request. Also see page 3.

HALFEN HZA-PS POWER SOLUTION System Solutions/Application Examples

Planning with our products provides a wide range of possible design solutions: Nuclear power plants (EVA and EVI impact load requirements); sewage plants with larger pipe sizes; very long cable runs; pipe supply lines in utility or other types of tunnels; various other fixings, even to curved or slanted surfaces.



Stacked cable trays fixed to vertical serrated channels



Cantilever fixed to a vertical serrated channel for pipe support



Pipe fixed to anchor channels cast into a ceiling slab

More than 90 Years of experience is packed into our products. Contact the our support team to design and effectively dimension a project.

See the back of the catalogue for contact addresses or go to www.halfen.com



Pipe support fixed to vertical cast-in serrated channel



Cantilever fixed to vertical serrated channel for pipe support

HALFEN HZA-PS POWER SOLUTION

HALFEN System Solutions/Channel ring

Example: designing with the our Engineering Support Team

Our technical support team starts with outline drawings, which should include some basic information.

From your drawings...

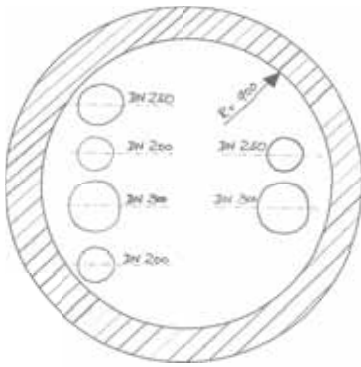

..to a detailed design and a successful project

Standard and custom elements are combined when designing a pipe support system; this ensures the best and most economical solution for a specific project.

Our Engineering Support Team always strive to achieve the best balance between safety and economy. Always working in close cooperation with the customer throughout the design process to find the best connections for a project. See the back of the catalogue for contact addresses or go to www.halfen.com

Serrated framing channel

Alternative: Serrated anchor channel

Example for a hinged beam

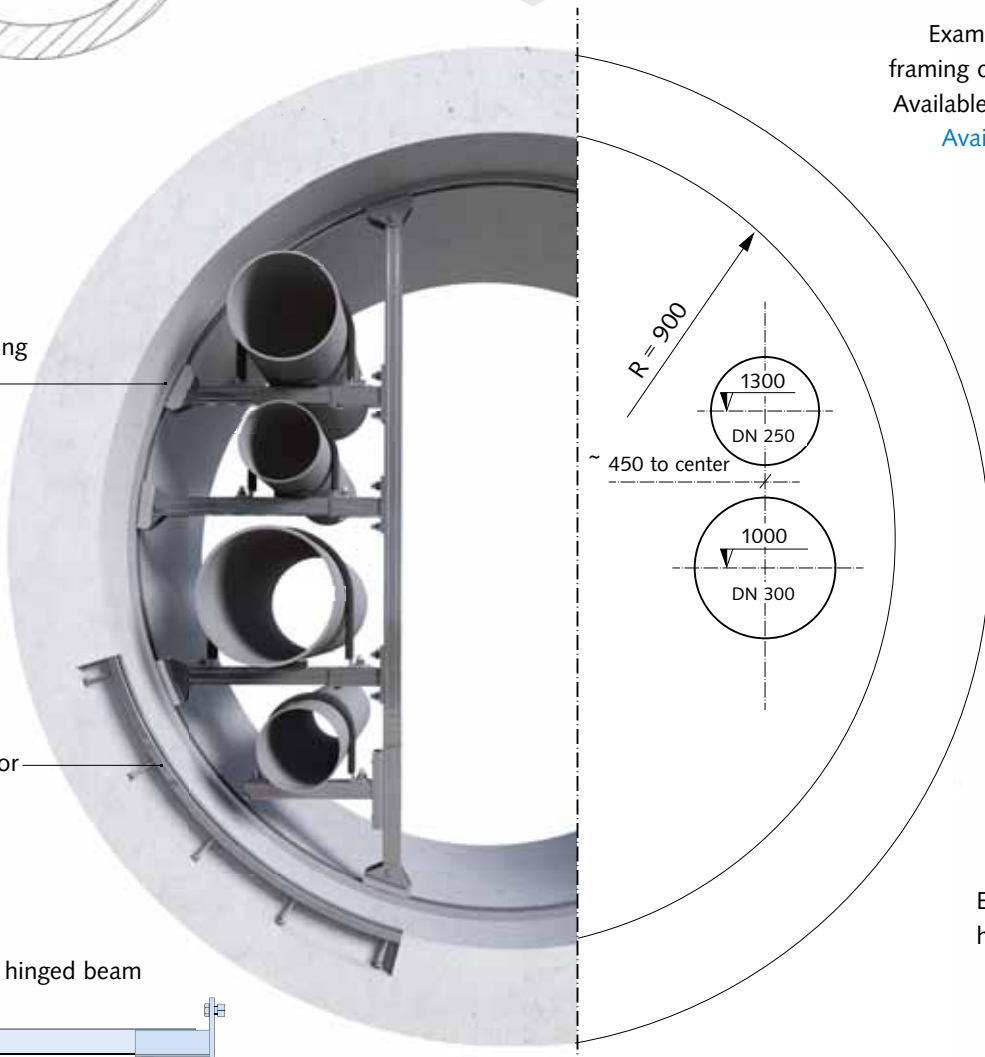





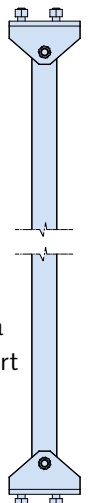





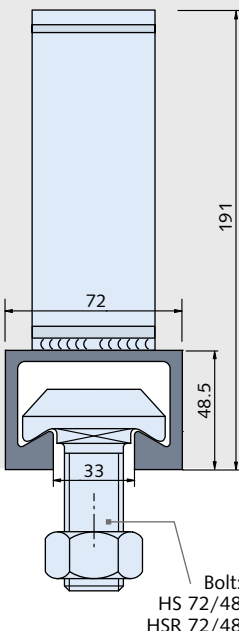

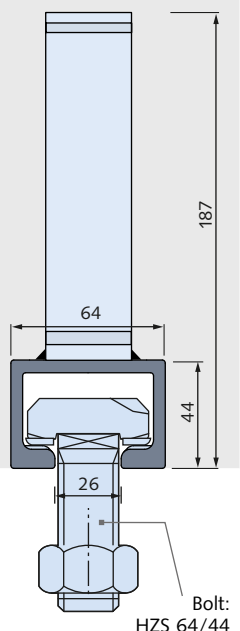
Example of a medium duty framing channel ring HCS-SRI. Available in hot-dip galvanized
Available in stainless steel

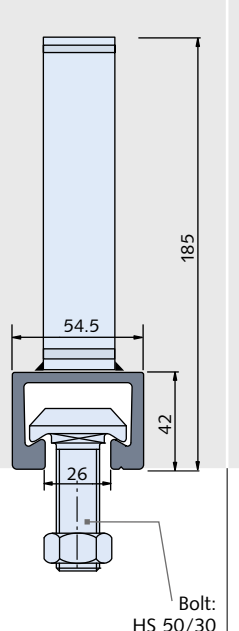
Example for a hinged support

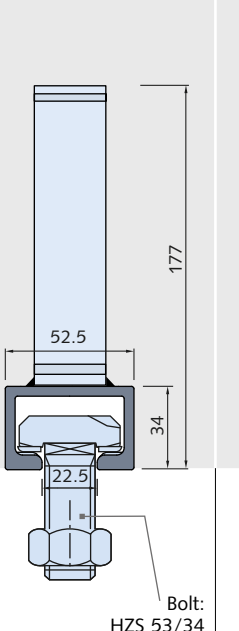

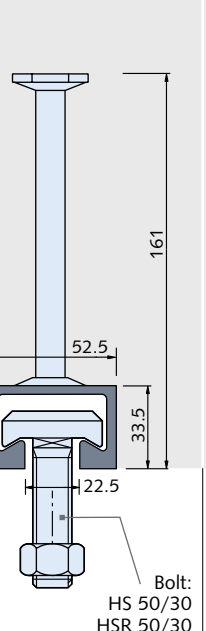
HALFEN HZA-PS POWER SOLUTION

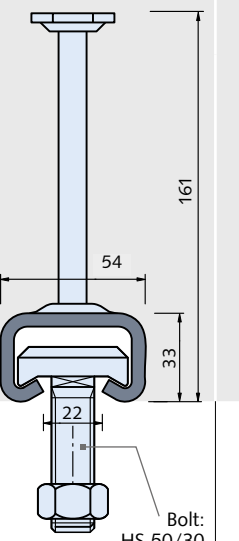
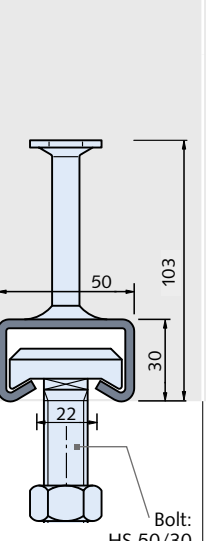
HALFEN HTA-CE/HZA Cast-in Channels

hot-rolled	HTA-CE 72/48  	HZA 64/44  	HTA-CE 55/42  	HZA 53/34  	HTA-CE 52/34  	
	<p>Bolt: HS 72/48 HSR 72/48</p> <p>Material:</p> <p>■ <input type="checkbox"/> <input checked="" type="checkbox"/></p>	<p>Bolt: HZS 64/44</p> <p>Material:</p> <p>■ <input type="checkbox"/> <input checked="" type="checkbox"/></p>	<p>Bolt: HS 50/30</p> <p>Material:</p> <p>■ <input type="checkbox"/> <input checked="" type="checkbox"/></p>	<p>Bolt: HZS 53/34</p> <p>Material:</p> <p>■ <input type="checkbox"/> <input checked="" type="checkbox"/></p>	<p>Bolt: HS 50/30 HSR 50/30</p> <p>Material:</p> <p>■ <input type="checkbox"/> <input checked="" type="checkbox"/></p>	
	<p>HALFEN Cast-in channels are available in cold-rolled or hot-rolled designs, with serrated or non-serrated channel lips. Other Information not included here; calculation notes, installation and further application examples can be found in the HALFEN Cast-in channels, Technical Product Information:</p> <p>Free download at: www.halfen.com</p>					
	cold-rolled				HTA-CE 54/33 	HTA-CE 49/30 
		<p>■ FV = steel, hot-dip galvanized</p> <p>■ A4 = stainless steel</p> <p>■ <input checked="" type="checkbox"/> HCR = high corrosion resistant steel</p>			<p>suitable for dynamic loads</p> 	<p>serrated channel</p> 

HALFEN HZA-PS POWER SOLUTION

HALFEN HTA-CE/HZA Cast-in Channels

HTA-CE 50/30-P

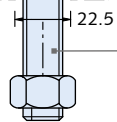
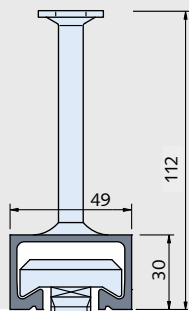

Bolt:
HS 50/30
HSR 50/30

Material:



HZA 38/23

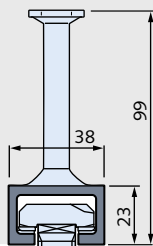
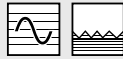

Bolt:
HZS 38/23

Material:



HTA-CE 40/22-P

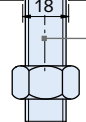
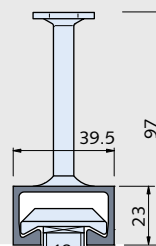

Bolt:
HS 40/22
HSR 40/22

Material:



HZA 29/20

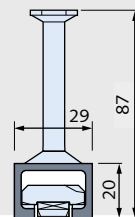
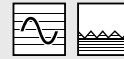

Bolt:
HZS 29/20

Material:



HTA-CE 40/25

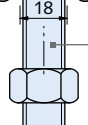
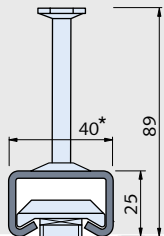

Bolt:
HS 40/22

Material:

■ * 40

■ * 39.5

HZA 41/22

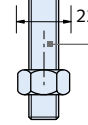
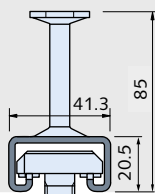

Bolt:
HZS 41/22

Material:



HTA-CE 38/17

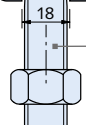
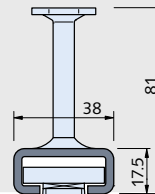

Bolt:
HS 38/17

Material:



HTA-CE 28/15

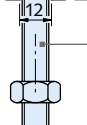
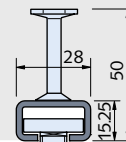

Bolt:
HS 28/15

Material:



HALFEN HZA-PS POWER SOLUTION

System Solutions/Application Examples

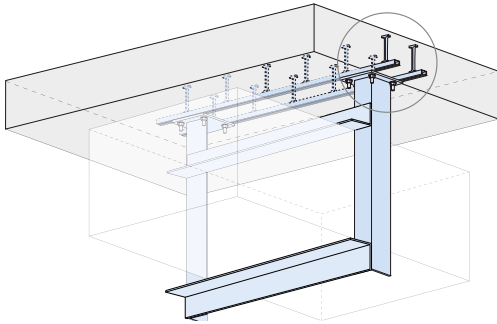

Air ventilation duct
supported with a welded
steel frame anchored to
a concrete slab with a
pair of serrated channels

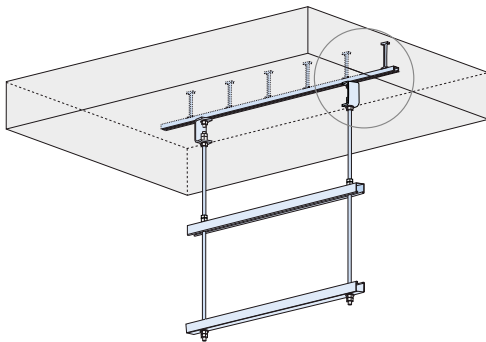
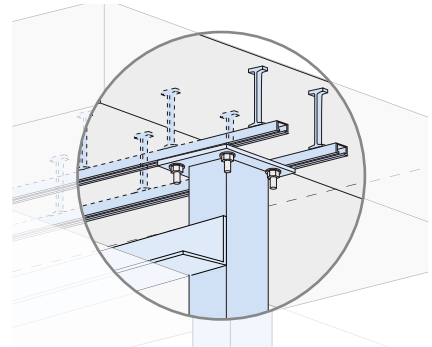

**Air ventilation duct
support**
suspended as a light
weight system
bolted to a concrete slab
using a serrated channel

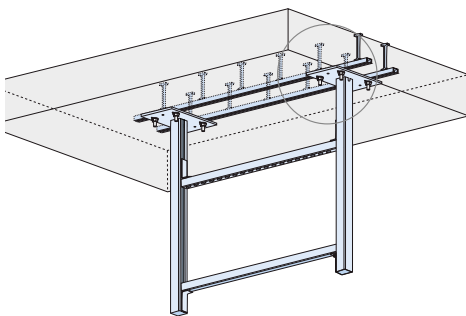
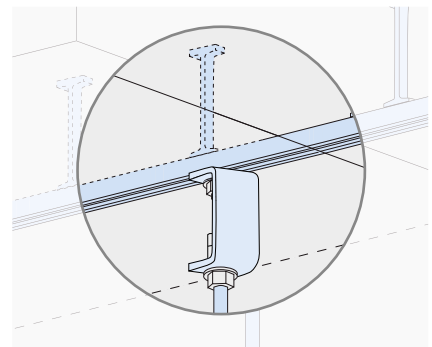

**Air ventilation duct
support**
a HALFEN Framing system
suspended from a
concrete slab with a pair
of serrated channels

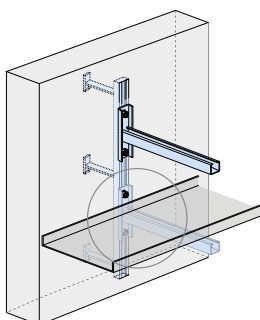
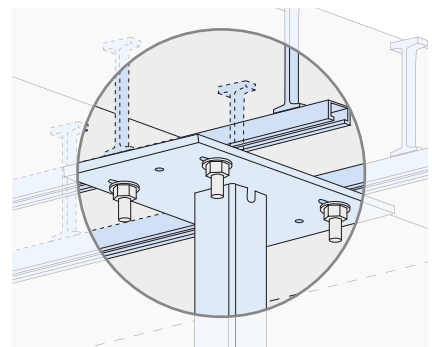

Cable tray support
cantilever brackets
fixed to a vertical
serrated channel

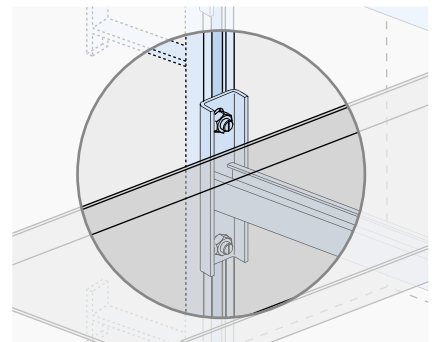

HALFEN HZA-PS POWER SOLUTION System Solutions/Application Examples

A revolution in pipe support in tunnels! The HALFEN Adjustable cantilever combines the acclaimed high load bearing capacity of the medium duty system with a much faster installation. Specially designed for use in tunnels or other applications with curved or slanted surfaces. It is not necessary to know the cantilever angles at planning.

One part for all fixings, dramatically reduces complexity.

No custom cantilevers required, no angles to measure.

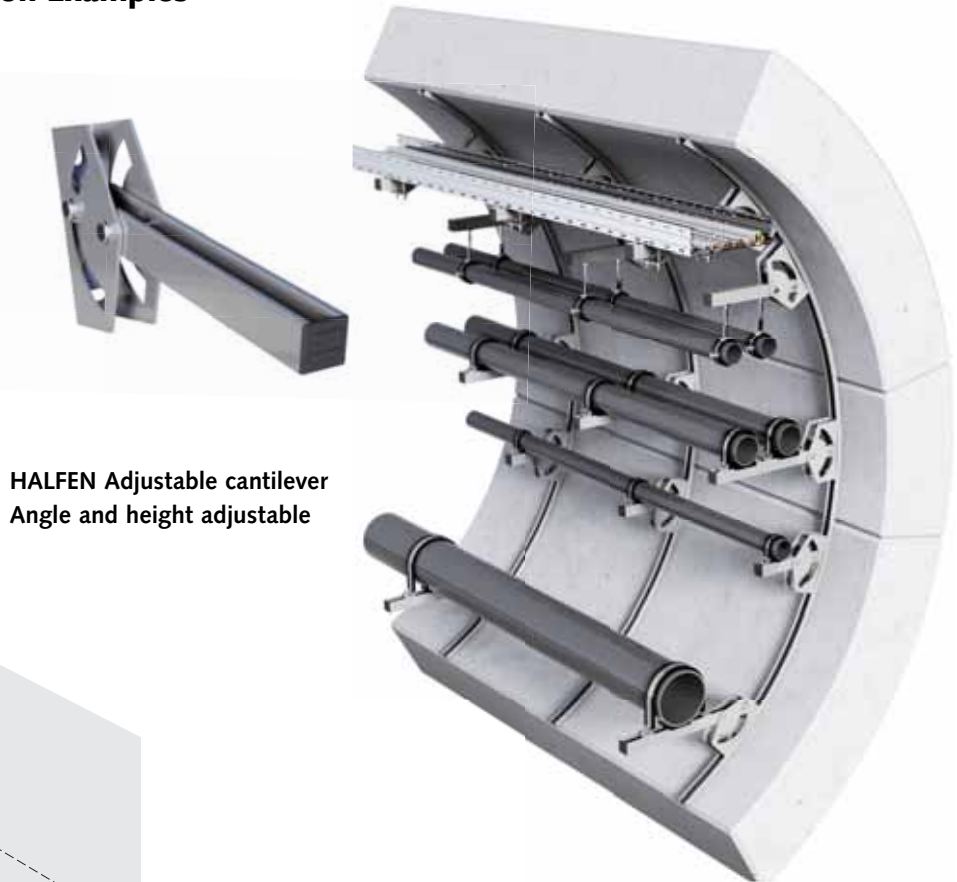

HALFEN Adjustable cantilever
Angle and height adjustable

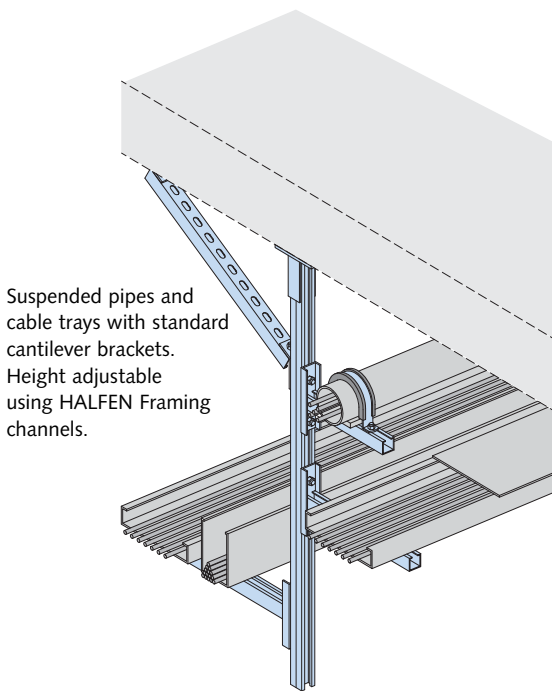

Suspended pipes and cable trays with standard cantilever brackets. Height adjustable using HALFEN Framing channels.

HALFEN Cantilever
height adjustable

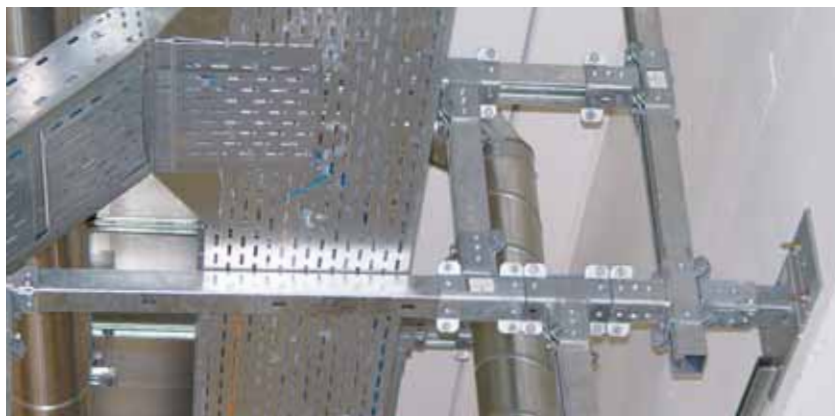

Typical application of the HALFEN System: Anchor and framing channels with Powerclick and framing fittings

The HALFEN Framing system product range can be found in the following catalogues:

- HALFEN Flexible bolt connections,**
- HALFEN Flexible framing connections**
- HALFEN Powerclick System.**



HALFEN HZA-PS POWER SOLUTION

System solutions/Application Examples

Example for standard cantilever with loads

HALFEN can supply standard cantilevers with European Technical Approval from stock. This brief extract from the main catalogue illustrates just some of the available KON 52/2 cantilevers and the corresponding working loads (allow. load) i.e. the design resistances acc. to Eurocode 3 (F_{Rd}). For more information please see the MT-FFC Flexible Framing Construction catalogue.

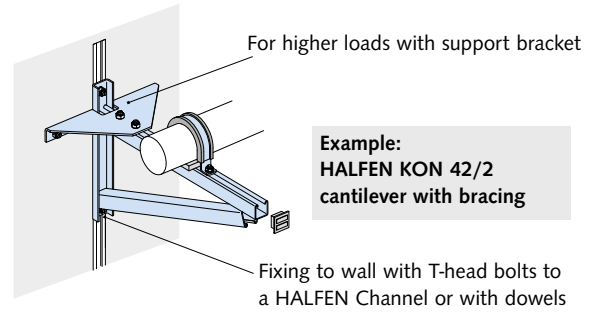

Example:
HALFEN KON 42/2
cantilever with bracing

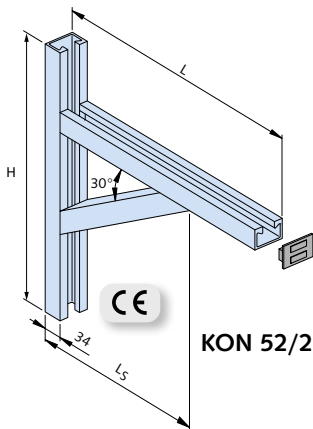

KON 52/2 Extract with sizes and load bearing capacities

Dimensions			hot-dip galvanized FV	stainless steel A4				
Length L [mm]	Height H [mm]	Length Ls [mm]	Order no. 0310.080-	Order no. 0310.080-	F [kN]	F ₁	F ₁	F ₂
500	450	330	00001	00008	allow. load	9.0	15.0	7.5
					F_{Rd}	12.6	21.0	10.5
600	475	380	00002	00009	allow. load	8.0	15.0	7.5
					F_{Rd}	11.2	21.0	10.5
700	500	430	00003	00010	allow. load	7.0	15.0	6.5
					F_{Rd}	9.8	21.0	9.1
800	550	480	00004	00011	allow. load	6.0	15.0	6.0
					F_{Rd}	8.4	21.0	8.4

Example for a custom cantilever solution

Cantilever for a safety relevant area at the ITER fusion reactor (France). Customized cantilevers for a cable tray support, installed to a HALFEN Cast-in channels.

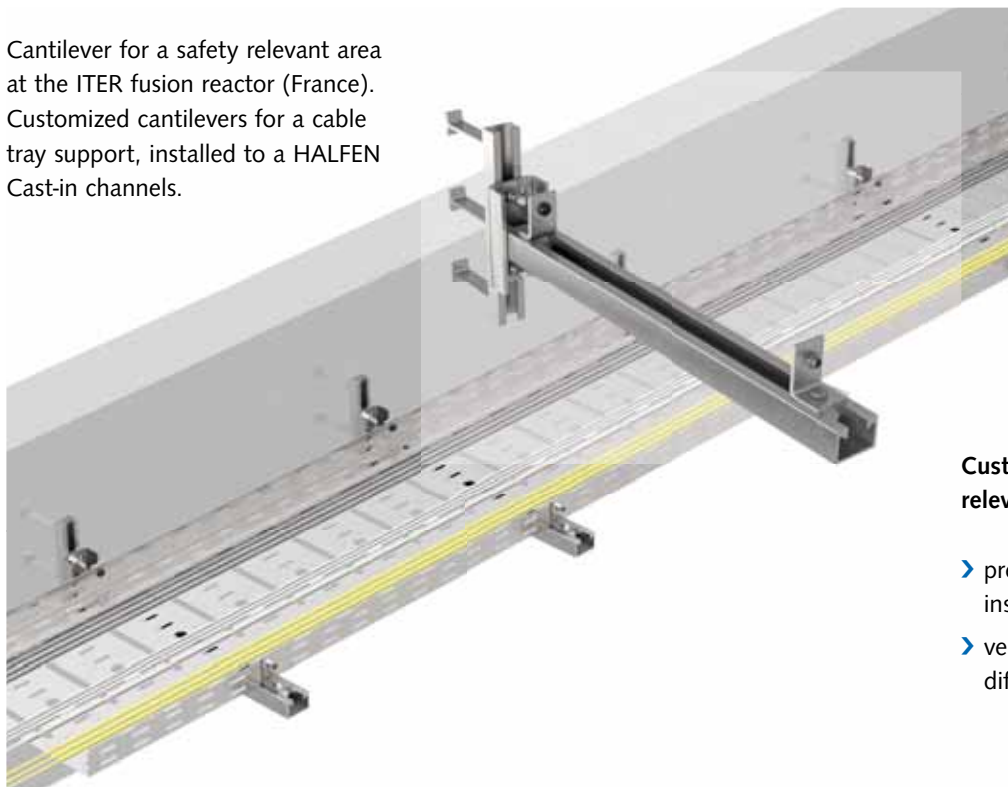

Custom cantilever for a safety relevant area:

- > pre-assembled fixings provide fast installation
- > versatile and reliable support for different types of cable trays





Leviat®

Innovative engineered products
and construction solutions that
allow the industry to build safer,
stronger and faster.

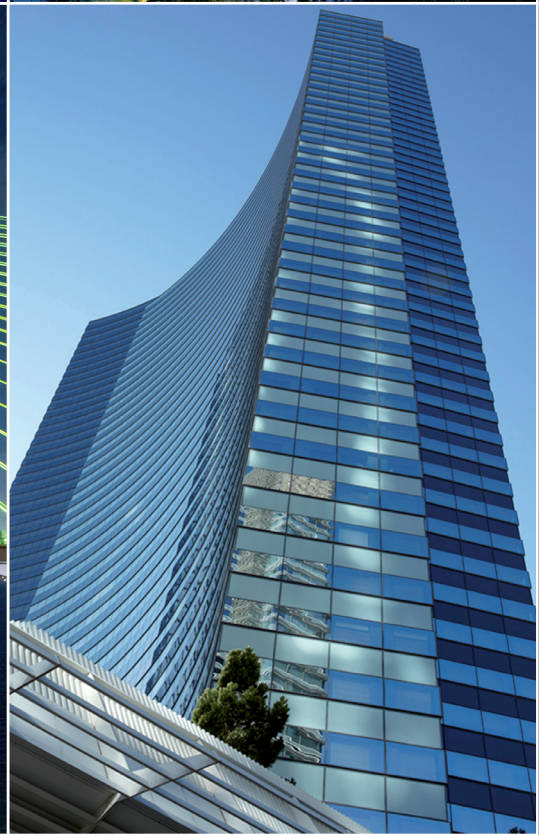

Contact Leviat worldwide

Australia

Unit A, 1 Heinrich Close,
Eastern Creek, Sydney, NSW 2766
Tel: +61 - 2 8808 3100
Email: info.au@leviat.com

Austria

Leonard-Bernstein-Str. 10
Saturn Tower, 1220 Wien
Tel: +43 - 1 - 259 6770
Email: info.at@leviat.com

Belgium

Industrielaan 2
1740 Ternat
Tel: +32 - 2 - 582 29 45
Email: info.be@leviat.com

China

Room 601 Tower D,
Vantone Centre
No. A6 Chao Yang Men Wai Street
Chaoyang District
Beijing P.R. China 100020
Tel: +86 - 10 5907 3200
Email: info.cn@leviat.com

Czech Republic

Pekařská 695/10a
155 00 Praha 5
Tel: +420 - 311 - 690 060
Email: info.cz@leviat.com

Finland

Vädursgatan 5
412 50 Göteborg / Sweden
Tel: +358 (0)10 6338781
Email: info.fi@leviat.com

France

6, Rue de Cabanis
31240 L'Union
Tel: +33 (0)5 34 25 54 82
Email: info.fr@leviat.com

Germany

Liebigstrasse 14
40764 Langenfeld
Tel: +49 - 2173 - 970 - 0
Email: info.de@leviat.com

India

Unit S4, 902, A Wing,
Lodha iThink Techno Campus Building,
Panchpakhadi, Pokharan Road 2,
Thane, 400606
Tel: +91-022 695 33700
Email: info.in@leviat.com

Italy

Via F.lli Bronzetti 28
24124 Bergamo
Tel: +39 - 035 - 0760711
Email: info.it@leviat.com

Malaysia

28 Jalan Anggerik Mokara 31/59
Kota Kemuning,
40460 Shah Alam Selangor
Tel: +603 - 5122 4182
Email: info.my@leviat.com

Netherlands

Oostermaat 3
7623 CS Borne
Tel: +31 - 74 - 267 14 49
Email: info.nl@leviat.com

New Zealand

246D James Fletcher Drive, Otahuhu,
Auckland 2024
Tel: +64 - 9 276 2236
Email: info.nz@leviat.com

Philippines

27F Office A, Podium West Tower,
12 ADB Avenue, Ortigas Center
Mandaluyong City, 1550
Tel: +63 - 2 7957 6381
Email: info.ph@leviat.com

Poland

Ul. Obornicka 287
60-691 Poznań
Tel: +48 - 61 - 622 14 14
Email: info.pl@leviat.com

Singapore

10 Benoi Sector,
Singapore 629845
Tel: +65 - 6266 6802
Email: info.sg@leviat.com

Spain

Polígono Industrial Santa Ana
c/ Ignacio Zuloaga, 20
28522 Rivas-Vaciamadrid
Tel: +34 - 91 632 18 40
Email: info.es@leviat.com

Sweden

Vädursgatan 5
412 50 Göteborg
Tel: +46 - 31 - 98 58 00
Email: info.se@leviat.com

Switzerland

Grenzstrasse 24
3250 Lyss
Tel: +41 (0)800 22 66 00
Email: info.ch@leviat.com

United Arab Emirates

RA08 TB02, PO Box 17225
JAFZA, Jebel Ali, Dubai
Tel: +971 (0)4 883 4346
Email: info.ae@leviat.com

United Kingdom

President Way,
President Park,
Sheffield S4 7UR
Tel: +44 - 114 275 5224
Email: info.uk@leviat.com

USA / Canada

6467 S Falkenburg Road
Riverview, FL 33578
Tel: (800) 423-9140
Email: info.us@leviat.us

For countries not listed

Email: info@leviat.com

Notes regarding this document

© Protected by copyright. The information in this publication is based on state-of-the-art technology at the time of publication. In every case, project working details should be entrusted to appropriately qualified and experienced persons. Leviat shall not accept liability for the accuracy of the information in this document or for any printing errors. We reserve the right to make technical and design changes at any time. With a policy of continuous product development, Leviat reserves the right to modify product design and specification at any time.

Leviat®

Imagine. Model. Make.

Leviat.com