

Leviat®

Ancon®

Reinforcement Continuity Systems

for the Construction Industry

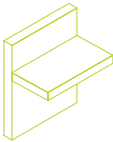
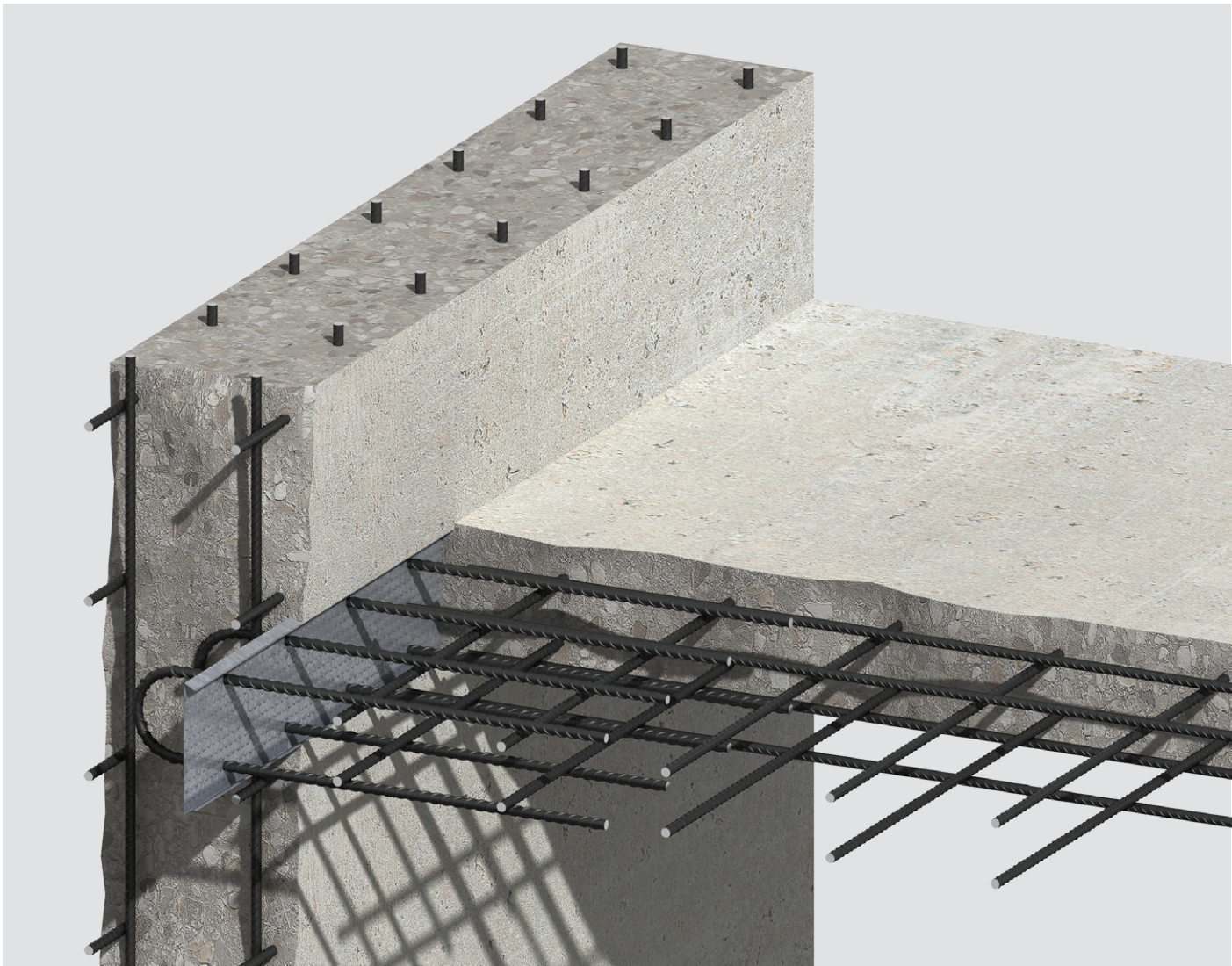

Structural Connections
Shear Load Connectors

Imagine. Model. Make.

Leviat®

We imagine, model and make engineered products and innovative construction solutions that help turn architectural visions into reality and enable our construction partners to build better, safer, stronger and faster.

Leviat is a world leader in connecting, fixing, lifting and anchoring technology.

From the build of new schools, hospitals, homes and infrastructure, to the repair and maintenance of heritage structures, our engineering skills are making a difference around the world.

We provide technical design assistance at every stage of a project, from initial planning to installation and beyond.

Our technical support services range from simple product selection through to the development of a fully customised project-specific design solution.

Every promise we make locally, has the commitment and dedication of our global team behind it. We employ almost 3,000 people at 60 locations across North America, Europe and Asia-Pacific, providing an agile and responsive service worldwide.





>3,000
People

60+
Locations

~23
Countries

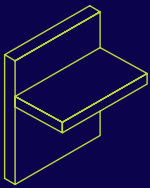

Structural Connections

Systems to form robust, efficient connections, and continuity of concrete reinforcement as necessary, between walls, slabs, columns, beams and balconies, providing structural integrity as well as enhanced thermal and acoustic performance.

- Insulated balcony connectors
- Reinforcing bar couplers
- Concrete Connections
- Reinforcement continuity systems
- Punching shear reinforcement
- Shear load connectors
- Floor Joint Systems
- Precast / Reinforced Columns
- Infrastructure Products
- Precast Connections
- Acoustic dowels and bearings
- Prestress

Other areas of expertise:

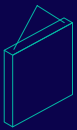

Lifting & Bracing

Systems for the safe and efficient transportation, lifting and temporary bracing of cast concrete elements and tilt-up panels before permanent structural connections are made.



Façade Support & Restraint

Systems for the safe and thermally-efficient fixing of the external building envelope, including brick and natural stone, insulated sandwich panels, curtain walling and suspended concrete façades, and also the repair and strengthening of existing masonry installations.

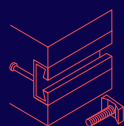

Anchoring & Fixing

Systems for fixing secondary fixtures to concrete, including anchor channels, bolts and inserts; also tension rod systems for roofs and canopies.



Formwork & Site Accessories

Non-structural accessories that complement our engineered solutions and help keep your construction environment operating safely and efficiently, including moulds for casting standard and special concrete elements and construction essentials such as reinforcing bar spacers.

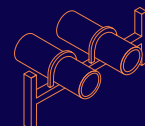

Industrial Technology

Mounting channels, pipe clamps and other versatile framing systems that provide safe fixing in a wide range of industrial applications.

Leviat product ranges:

Ancon | Aschwanden | Connolly | Halfen | Helifix | Isedio | Meadow Burke | Modersohn | Moment | Plaka | Scaldex | Thermomass

Reinforcement Continuity Systems

Contents

Ancon Keybox Reinforcement Continuity System	6
Bar Arrangement Types	8
Ancon Keybox Identification	10
Order Form	13
Ancon Coupler Box Reinforcement Continuity System	15
Ancon Coupler Box Identification	17
Order Form	22
Ancon KSN Anchor Box Reinforcement Continuity System	23
Ancon KSN Anchor Box Identification	25
Order Form	29
Ancon BT Starter Bars	30
Other Ancon Products	32

The use of reinforcement continuity systems is a widely accepted means of providing continuity of reinforcement across construction joints in concrete. Within the construction joints, the steel reinforcement should be continued while the formwork needs to continue to allow for separate pours. Traditional solutions required the formwork to be punctured to let the reinforcement bars through. Leviat's range of reinforcement continuity systems offer an advanced solution by allowing continuity in the reinforcement while an incessant formwork is used. They are not only perfect for accelerating the construction process and increasing safety, but also offer economic benefits if applied at large scale in big construction projects.

Leviat offers three products for this purpose: Ancon Keybox, Ancon Coupler Box and Ancon KSN Anchor Box. Each system has its own benefits, and the full range of reinforcement continuity systems covers most applications. All three systems use the galvanised steel casing to form a recess in the concrete of the first pour that will work as a shear key.

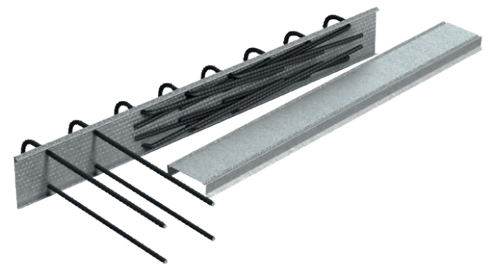

Ancon Keybox Rebend Box System using N12 reinforcement bars temporarily bent into the box



Ancon Coupler Box using the Ancon BT Coupler system with Ancon BT Starter Bars

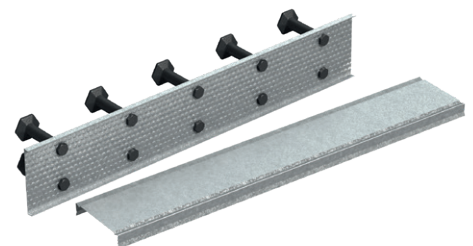

Ancon KSN Anchor Box using Ancon KSN Anchors with Ancon BT Starter Bars

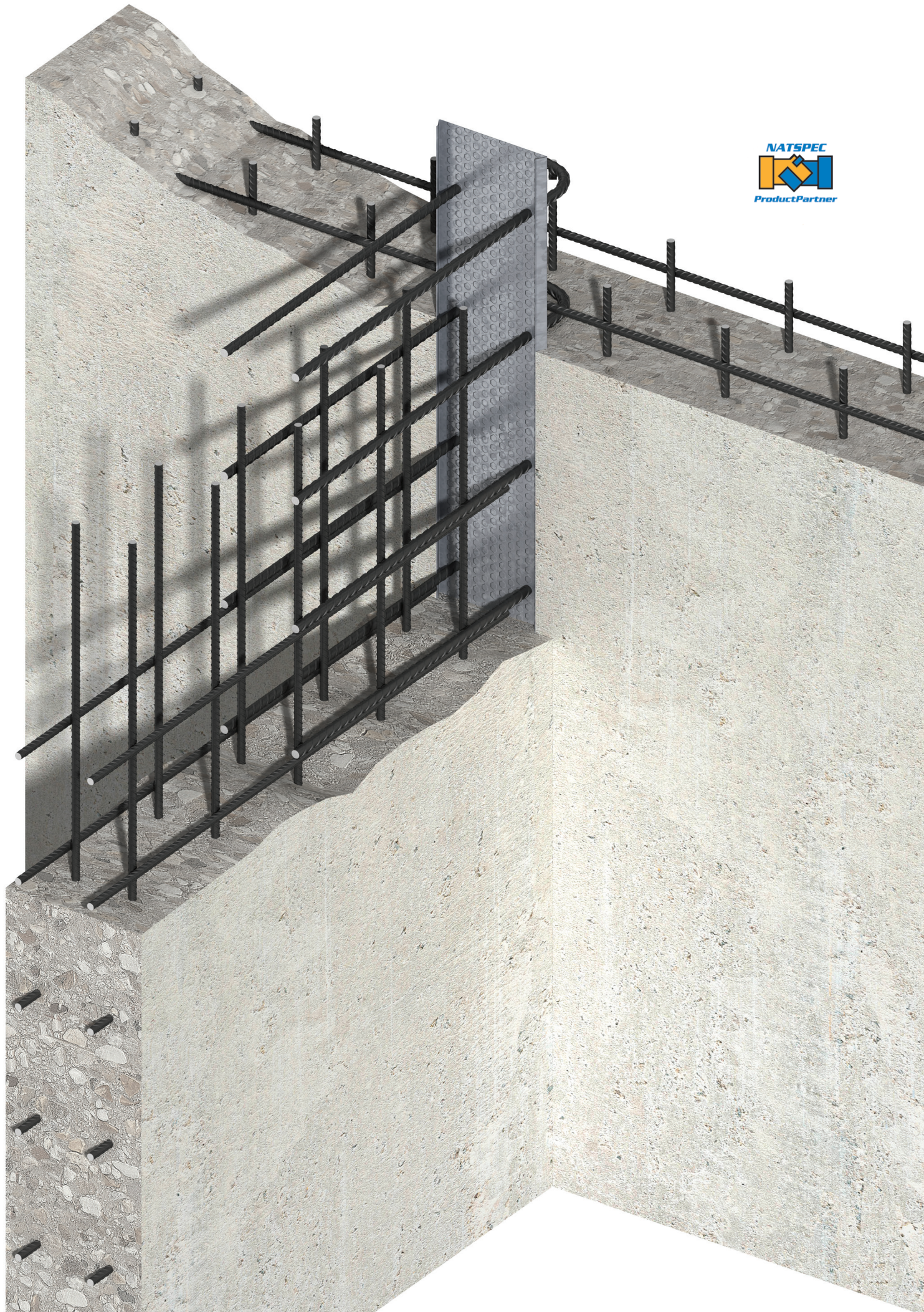

Reinforcement Continuity Systems

1

Ancon Keybox Reinforcement Continuity System

The Keybox Reinforcement Continuity System is a quick and easy to install method of maintaining continuity of reinforcement at construction joints in concrete. It consists of a galvanised steel casing with a dimpled surface to provide an effective concrete bond. Pre-bent bars are housed within the casing and are enclosed by a protective cover. Each end of the unit is sealed with a polystyrene block in order to prevent the ingress of concrete. The complete unit is nailed to the formwork. Alternatively, it can be wired back to the main reinforcement cage. The concrete is then cast. After striking the formwork, the cover is removed and the bars are straightened, ready for lapping onto the main reinforcement, using a Keybox re-bending tool. The steel casing remains embedded in the wall and is filled with concrete when the next section is poured, the dimpled surface providing an efficient key.

Use of the Ancon Keybox system offers many benefits over conventional joint construction, including the simplification of formwork design and removal of the need to drill shuttering. This contributes to the acceleration of the construction process. As the bars remain enclosed within the casing until required, they are protected and the risk of injury from projecting bars is minimised. Easy to use, the system requires no onsite training in order to carry out installation.

The Keybox system is potentially suitable for use in any construction joint in concrete, but the most commonly found applications include:

- Floor slabs
- Walls
- Stairwells
- Corbels
- Diaphragm walls
- Jumpforms
- Brick support ledges

Quality

Keybox Reinforcement Continuity Systems are manufactured using ACRS approved bar which meets the requirements of AS/NZS 4671:2019. The grade of reinforcing bar used is Grade 500N, minimum yield 500MPa, minimum uniform elongation A_{gt} 5%. The bars are bent in accordance with AS 3600:2018.



Eureka Tower, Melbourne, VIC

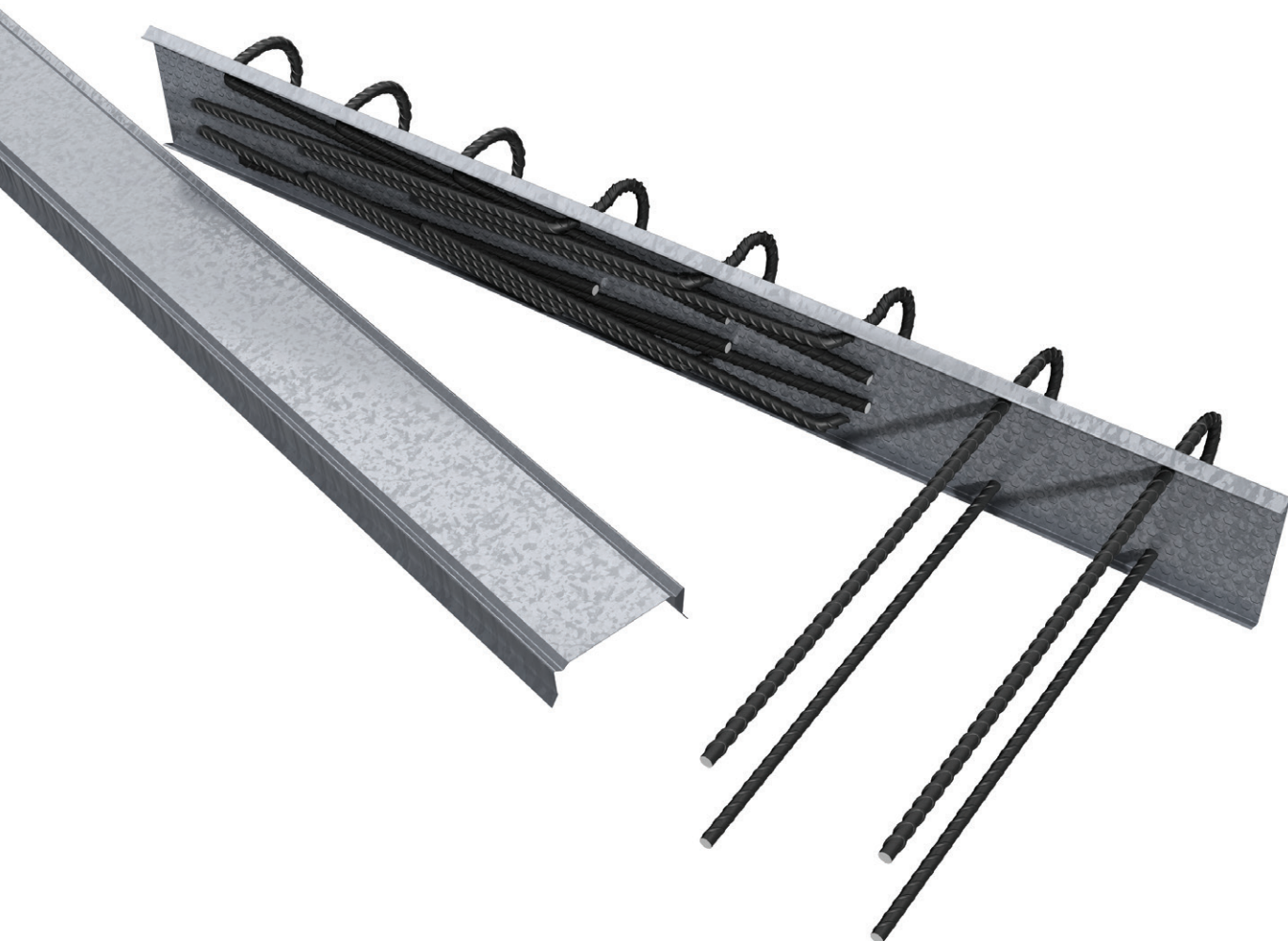





Reinforcement Continuity Systems

Bar Arrangement Types

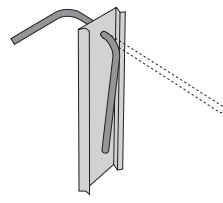
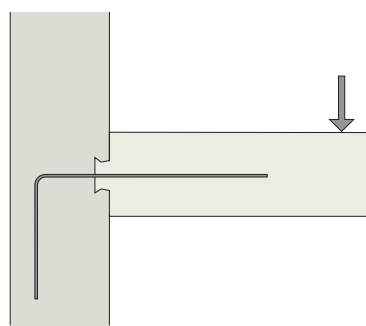
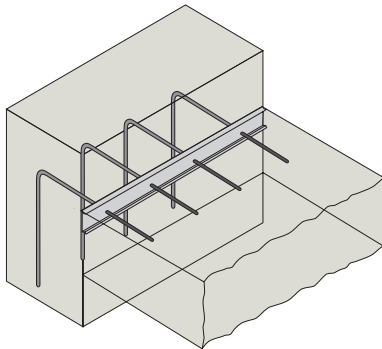
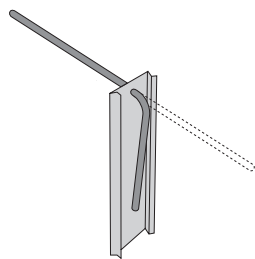
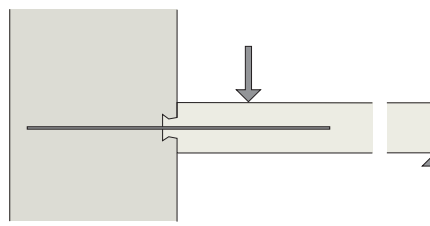
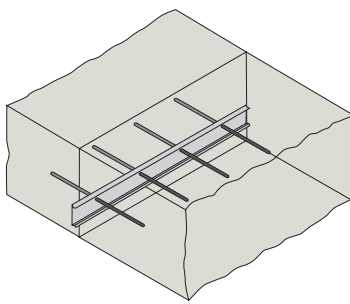
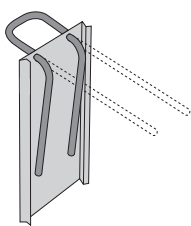
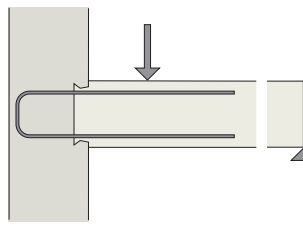
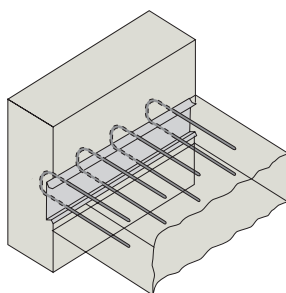
The below table represents the available standard bar arrangement types together with schematic samples of their applications.

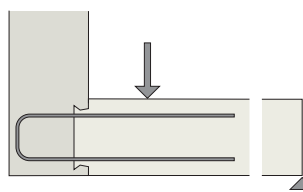
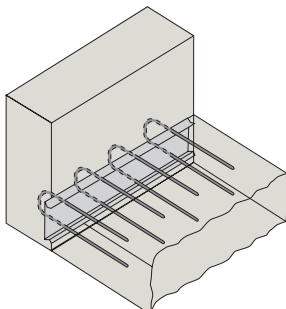
Bar Arrangement Type	Vertical Section	Application
<p>Type L (Bent bar, single row) Typically used for slab-to-slab or slab-to-wall connections</p> 		
<p>Type A (Straight bar, single row) Typically used for penetrations and wall-to-wall connections</p> 		
<p>Type U (U bar, double row) Typically used for slab-to-wall connections</p> 		
<p>Type U (U bar, double row) Typically used for slab-to-wall connections</p> 		

Bar Arrangement Type

Vertical Section

Application

Type LL

(Bent bars, double row)
Designed to fit within the specified casing providing two rows to lap onto

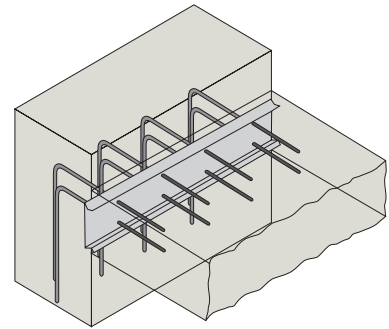
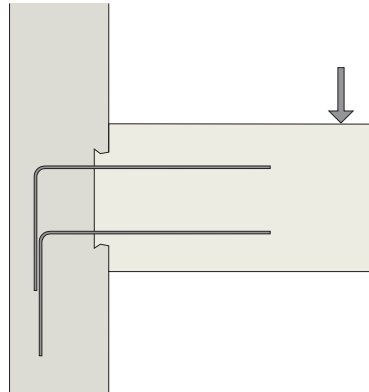
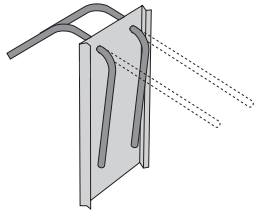

Type AA

(Straight bars, double row)
Designed to fit within the specified casing providing two rows to lap onto, typically used for penetrations

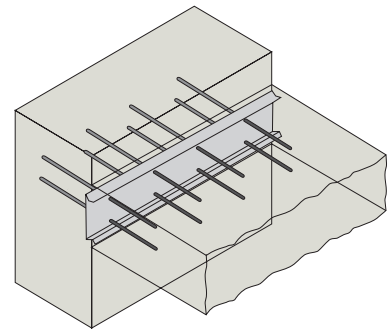
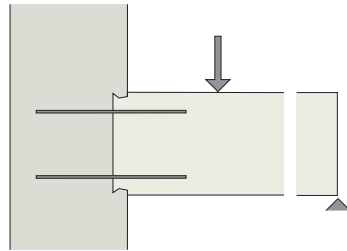
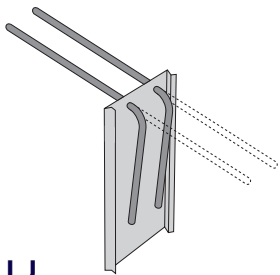

Type LJ

(Bent bars, double row)
Designed to fit within the specified casing providing two rows to lap onto

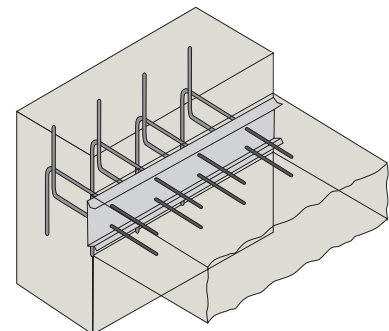
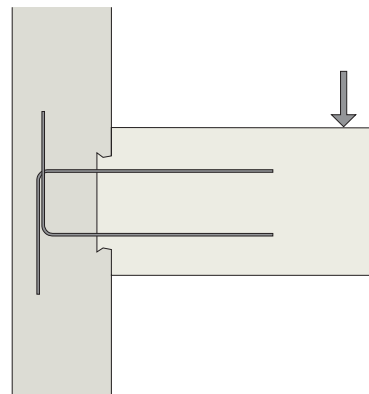
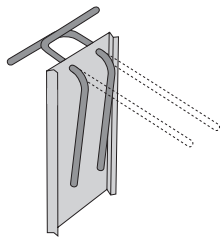

Type JL

(Bent bars, double row)
Designed to fit within the specified casing providing two rows to lap onto

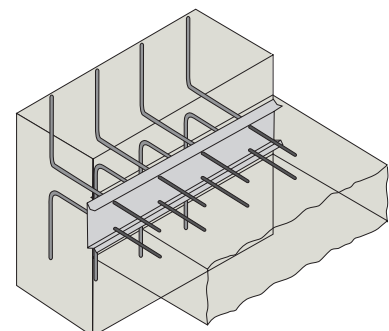
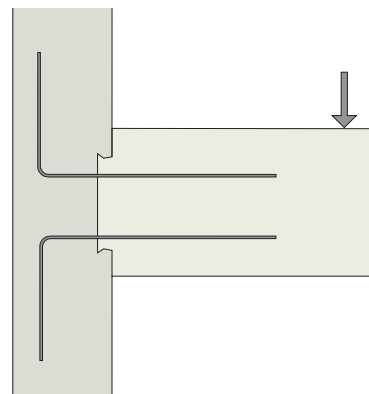
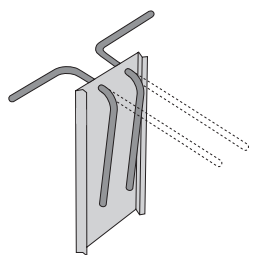

Reinforcement Continuity Systems

Keybox Identification

The description of a Keybox is generally of the form:

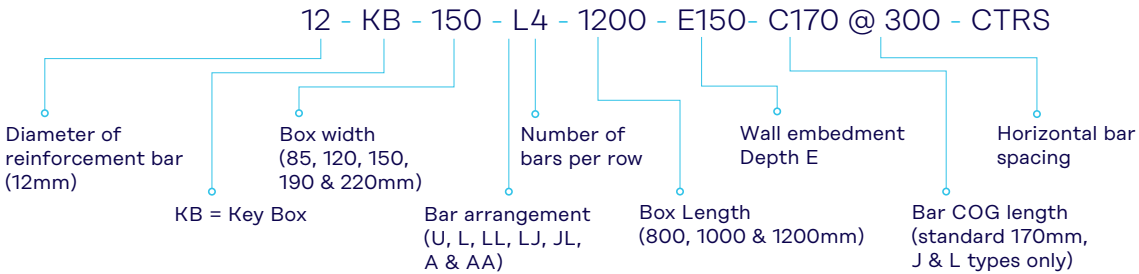

Bar Type

- Box widths can vary by joining smaller casings to form larger sizes (e.g., 150 + 190 = 340mm).
- The thinner the box width, the more difficult it is to fit more bars, e.g., 10 bars will not fit in a 120mm box.
- Standard casing lengths are 800mm, 1000mm and 1200mm. Please contact Levia for non-standard items.
- Minimum wall embedment (E) for types U, L & J is 130mm as standard from front of casing. Larger depths can be made where appropriate.
- Standard embedment (E) for type A is 535mm.
- Cog length (C) should be optimised to ensure maximum embedment, standard Cog Length for types L and J is 170mm.
- Minimum wall thickness for all types L & J Keyboxes is 160mm, assuming concrete cover of 30mm.
- Standard slab embedment (pullout) is P=480mm, but could be smaller due to manufacturing limitations.
- Ancon double row Keyboxes are designed to be installed at the top of the concrete pour. For conditions that require installation lower in the pour, the bars must be secured to the reinforcement cage or alternatively two single row boxes can be used. This will avoid buckling of the box profile and potential displacement of the bars caused by the pressure of the wet concrete.

Standard Range Configurations

KB 85 L

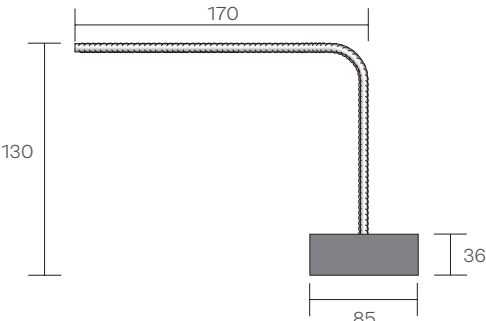

KB 120 U

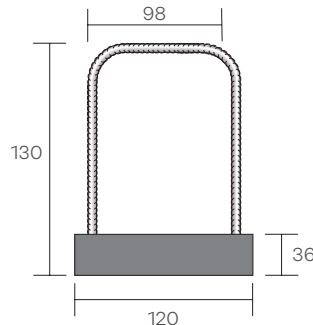

KB 150 U

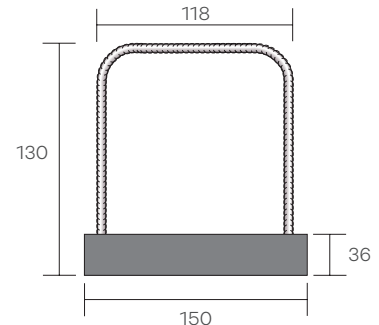

KB 190 U

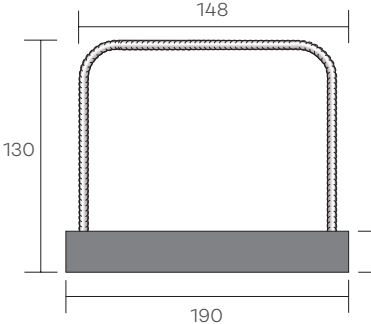

KB 220 U

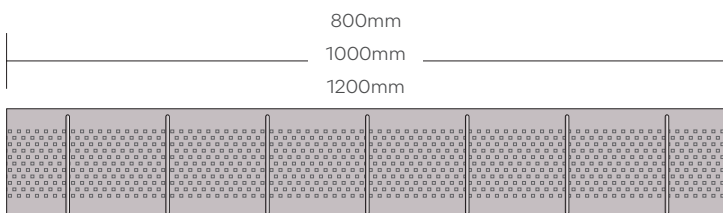
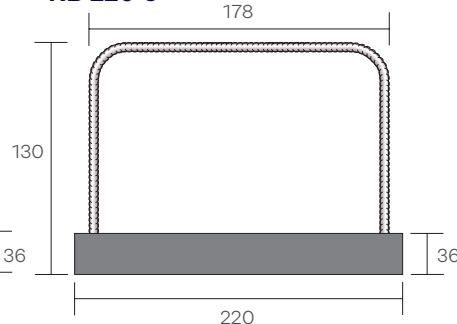

Different centres are available

An Enquiry/Order form is available on page 14, which can be used to simplify the order process. It is also available to download separately from the Ancon website. Link to this URL: <https://www.ancon.com.au/downloads/enquiry-forms>

Ancon Single Row Keybox (Type A)

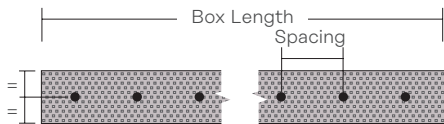

Ancon Double Row Keybox (Type AA)

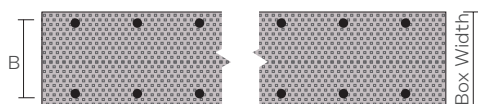

The above represents the slab thickness range for each Keybox width, which is based on 30mm concrete cover and 5mm tolerance. The parameter Outer Bar Spacing B in double row boxes (i.e., types AA, LL, LJ and JL) is equivalent to the stirrup width in the U type Keybox.

Double Row Box Spacing and Slab Range			
Bar Size	Box Width	Outer Bar Spacing B	Slab Thickness*
N12	120	98	165-185
	150	118	185-215
	190	148	215-245
	220	178	245-265

*Slab Thickness is based on 30mm concrete cover and 5mm tolerance.

* For thicker slabs, it is advised to use two or more rows of 85mm wide Keyboxes. Contact Leviat for further information.

Keybox system equivalent to N16 rebars

The standard Keyboxes are manufactured from N12 reinforcement bar. Leviat does not offer N16 Keyboxes as the rebending properties of the bar cannot be guaranteed. N16 rebend bars also present H&S considerations when rebending on site and the pullout length of the bar will be too short to meet the requirements of AS 3600 to develop the full strength of the bar.

Table on the right shows samples of Keybox systems equivalent to N16 reinforcements. The correspondence is done based on the compared tensile capacities of the two systems. Therefore, in each case the total section area of the N12 bars in Keybox system exceeds that of the N16 reinforcement bars at the mentioned centres.

Key Boxes equivalent to N16 reinforcement bar system	
N16 system	Equivalent Keybox
N16 @ 200 Centres	12 KB 150 U9 1000 @ 110 Centres
N16 @ 200 Centres	12 KB 150 U11 1200 @ 110 Centres
N16 @ 250 Centres	12 KB 150 U8 1000 @ 130 Centres
N16 @ 250 Centres	12 KB 150 U9 1200 @ 125 Centres
N16 @ 260 Centres	12 KB 150 U7 1000 @ 150 Centres
N16 @ 300 Centres	12 KB 150 U6 1000 @ 170 Centres
N16 @ 300 Centres	12 KB 150 U8 1200 @ 150 Centres
N16 @ 350 Centres	12 KB 150 U6 1000 @ 170 Centres
N16 @ 350 Centres	12 KB 150 U7 1200 @ 180 Centres
N16 @ 360 Centres	12 KB 150 U5 1000 @ 200 Centres
N16 @ 360 Centres	12 KB 150 U6 1200 @ 200 Centres
N16 @ 400 Centres	12 KB 150 U5 1000 @ 200 Centres
N16 @ 400 Centres	12 KB 150 U6 1200 @ 200 Centres
N16 @ 450 Centres	12 KB 150 U4 1000 @ 250 Centres
N16 @ 450 Centres	12 KB 150 U5 1200 @ 240 Centres

Installation Guidance on how to install Ancon Kebox system could be reviewed from Keybox Installation Guide.

Reinforcement Continuity Systems

Standard Range Specifications

The following table gives details of the Ancon Keybox range. Custom made boxes to suit project requirements are available on request. The most common bar arrangement types are shown on page 8 and 9. For further details please contact us.

U Type Box Dimensions

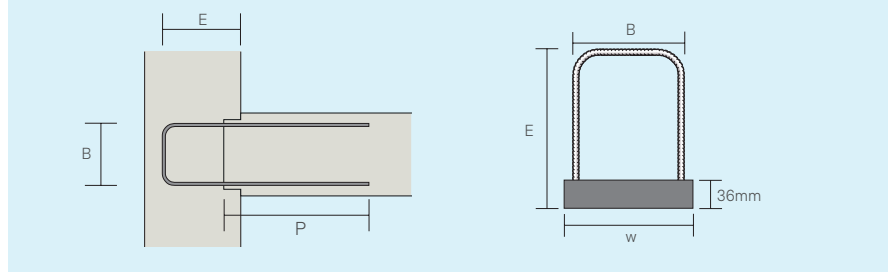

Part No.	Rebar Dia (mm)	Box Width (W) (mm)	Bar Arrangement	Bars per Row	Box Length (mm)	Minimum Embedment (E) (mm)	Stirrup Width (B) / Cog Length (C) (mm)	Centres (mm)	Slab Thickness (mm)	Wall Thickness (mm)	Pull-out (mm)
12-KB-85-L7-1000	12	85	L	7	1000	130	170	150	≥100	≥160	480
12-KB-85-L8-1200	12	85	L	8	1200	130	170	150	≥100	≥160	480
12-KB-85-L5-1000	12	85	L	5	1000	130	170	200	≥100	≥160	480
12-KB-85-L6-1200	12	85	L	6	1200	130	170	200	≥100	≥160	480
12-KB-120-U7-1000	12	120	U	7	1000	130	98	150	165-185	≥160	480
12-KB-120-U8-1200	12	120	U	8	1200	130	98	150	165-185	≥160	480
12-KB-120-U5-1000	12	120	U	5	1000	130	98	200	165-185	≥160	480
12-KB-120-U6-1200	12	120	U	6	1200	130	98	200	165-185	≥160	480
12-KB-150-U7-1000	12	150	U	7	1000	130	118	150	185-215	≥160	480
12-KB-150-U8-1200	12	150	U	8	1200	130	118	150	185-215	≥160	480
12-KB-150-U5-1000	12	150	U	5	1000	130	118	200	185-215	≥160	480
12-KB-150-U6-1200	12	150	U	6	1200	130	118	200	185-215	≥160	480
12-KB-190-U7-1000	12	190	U	7	1000	130	148	150	215-245	≥160	480
12-KB-190-U8-1200	12	190	U	8	1200	130	148	150	215-245	≥160	480
12-KB-190-U5-1000	12	190	U	5	1000	130	148	200	215-245	≥160	480
12-KB-190-U6-1200	12	190	U	6	1200	130	148	200	215-245	≥160	480
12-KB-220-U7-1000	12	220	U	7	1000	130	178	150	245-265	≥160	480
12-KB-220-U8-1200	12	220	U	8	1200	130	178	150	245-265	≥160	480
12-KB-220-U5-1000	12	220	U	5	1000	130	178	200	245-265	≥160	480
12-KB-220-U6-1200	12	220	U	6	1200	130	178	200	245-265	≥160	480

Notes: Dimensions shown in the above table are nominal. Heights and lengths may vary by one bar diameter. Maximum box length is determined by practicality and weight. Suggested slab thicknesses are based on a minimum top and bottom cover of 30mm, as well as a 5mm tolerance.



Reinforcement Continuity Systems

Enquiry/Order Form - Ancon Keybox

Please provide product requirements and contact details. For orders please complete delivery details here:

Date Order Enquiry

Company

Address

State Post Code

Contact

Tel

Email

Delivery Date

Project

Delivery Address

State Post Code

Site Contact

Tel

Email

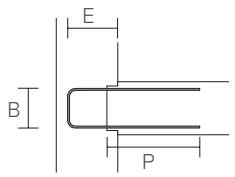

Type U U Bar
(not available in 85mm box)

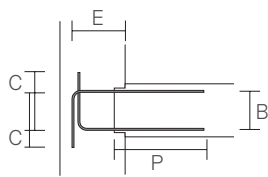

Type LJ Cog Bars

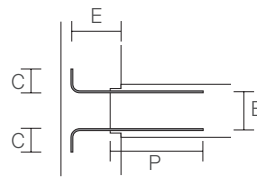

Type JL Cog Bars

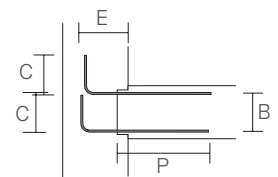

Type LL Cog Bars

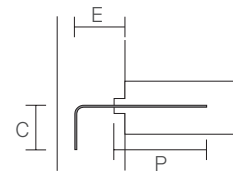

Type L Cog Bar

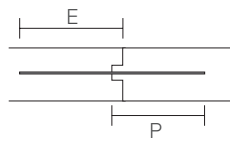

Type A Straight Bar

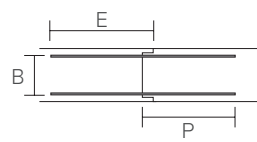

Type AA Double Straight Bars

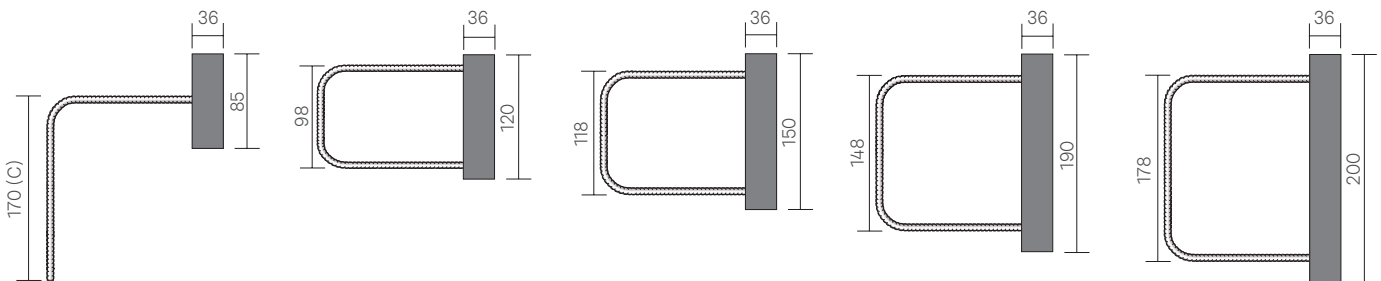

Reference	Quantity	Box Width (mm) (see above)	Bar Arrangement (see above)	Spacing (mm)	Box Length (mm) (see note 1)	Embedment E (mm) (see note 2)	Pullout P (mm) (see note 3)	Cog Length C (mm) (see note 4)

Re-bending Tool

Important: Bars must be straightened using a Keybox re-bending tool. Re-bend in one smooth motion. Do not straighten bars more than once.

Notes

- (1) Standard box lengths 800mm, 1000mm and 1200mm.
- (2) Minimum Embedment (E) of 130mm for U, L and J types and 535mm for A and AA types unless specified otherwise.
- (3) Standard pullout (P) 480mm, others available subject to limitations of box length.
- (4) Standard 170mm cog length for types L and J. Other cog lengths available.
- (5) The Ancon Keyboxes are all manufactured from N12 reinforcement bar.



2

Ancon Coupler Box Reinforcement Continuity System

Where the connecting bar is larger than 12mm, continuity of reinforcement can be provided by installation of an Ancon Coupler Box. These boxes combine standard Keybox casings with the Ancon BT mechanical splicing system. The BT mechanical splice is a full strength connection and is one of the smallest coupler systems in the market. More information can be found in the Ancon Reinforcing Bar Couplers brochure ([here](#)).

Ancon Coupler Boxes comprise couplers attached to a galvanised steel casing and fixed from inside by use of metal bolts which also act as thread protector. Like Keybox and KSN Anchor Box, it is enclosed by a protective steel lid and also sealed from sides by two polystyrene blocks to prevent ingress of concrete. All bars used in Ancon Coupler Boxes are manufactured from ACRS approved Grade 500N reinforcement steel with minimum yield strength of 500 MPa and minimum uniform elongation A_{gt} 5% which meets the requirements of AS/NZS 4671:2019.

When connecting beams or thick slabs to core walls, couplers are attached to the dimpled casing and cast into the wall with an appropriately designed embedment length of bar. This is typically an L-shaped bar, designed to be tied onto the wall reinforcement. Depending on the requirement from the customer, L-shaped bar can also be replaced by U-shaped or straight bars as long as the bending detail conforms to AS 3600: 2018 for the particular bar size.

The complete unit is nailed to the formwork. Alternatively, it can be wired back to the main reinforcement cage. The concrete is then cast. After striking the formwork, the boxes are exposed. When the box steel cover is stripped in the 2nd pour, the threaded continuation bars are screwed into the couplers leaving a lap length of bar for future connection. The steel casing remains embedded in the wall and is filled with concrete when the next section is poured, the dimpled surface providing an efficient key.



Reinforcement Continuity Systems

Typical Applications for Coupler Boxes

As a reinforcement continuity system, the typical applications for Ancon Coupler Boxes include slab-to-wall, wall-to-wall and slab-to-slab connections. The boxes could be cast in either horizontally or vertically within the concrete to fit horizontal slabs and vertical walls.

Ancon Coupler Boxes are manufactured to suit the requirements of specific projects. These boxes can be made in short lengths to simplify onsite handling. Use of the Ancon Coupler Box system offers many benefits over conventional joint construction, including the simplification of formwork design and removal of the need to drill shuttering. This contributes to the acceleration of the construction process. They replace the lapped joints and diminish the congestion within the concrete.

Available types

Ancon Coupler Boxes are available with N12-N32 reinforcement bar sizes. Various types are available based on the configuration of the fixed bars within the box, including types A and L for single row boxes and types AA, LL, LJ, JL and U for double row boxes. Type U Coupler Box could be made with $\pm 3\text{mm}$ tolerance in both in-plane and out-of-plane directions.

The range of six standard types in the Ancon Coupler Box suits the requirements of most applications. Coupler Boxes are available up to 32mm bar size as larger couplers are too heavy and would result in the box casing buckling issue.

Similar to Keybox system, the casing has a dimpled surface to provide an effective concrete bond. Like KSN Anchors, Ancon couplers also work with the proprietary BT threading system with the thread size larger than the bar itself to provide a ductile bar break splice with failure always happening on the bars far from the connection. The data on Ancon BT Starter Bars to be used as continuation bars for Coupler Box system could be found on page 31.

Single-row boxes

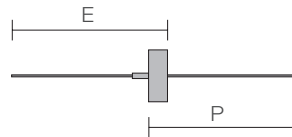

Type A

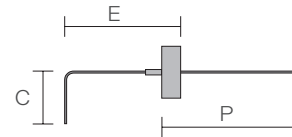

Type L

Double-row boxes

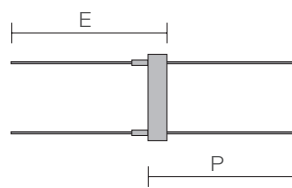

Type AA

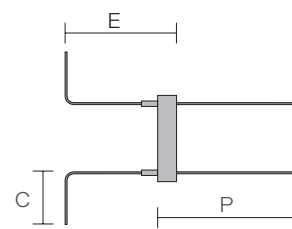

Type JL

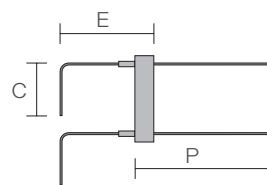

Type LL

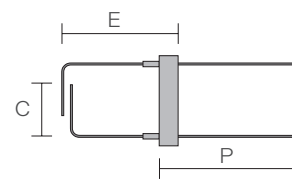

Type LJ

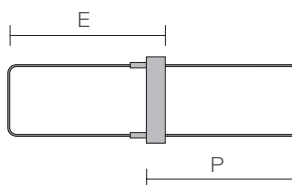

Type U

E = Total Embedment Depth computed from the front of the box casing
 C = Bar Cog Length
 P = Starter bar (continuation bar) Lap Length computed from inside of the box casing

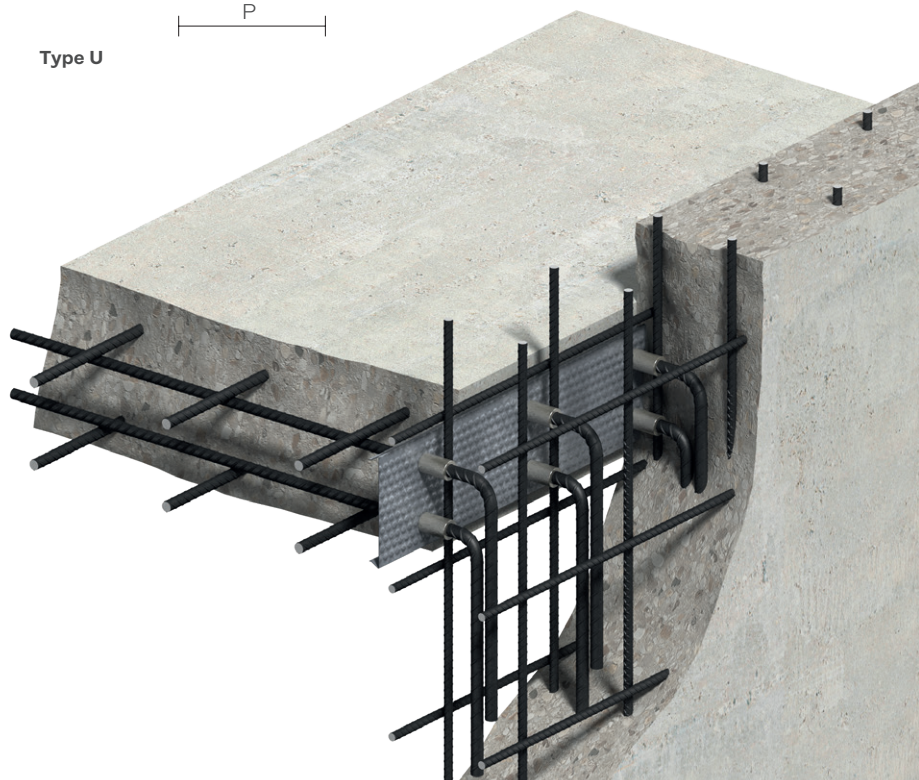

Ancon Coupler Box Identification

The Coupler Box could be fully defined using the below nomenclature:

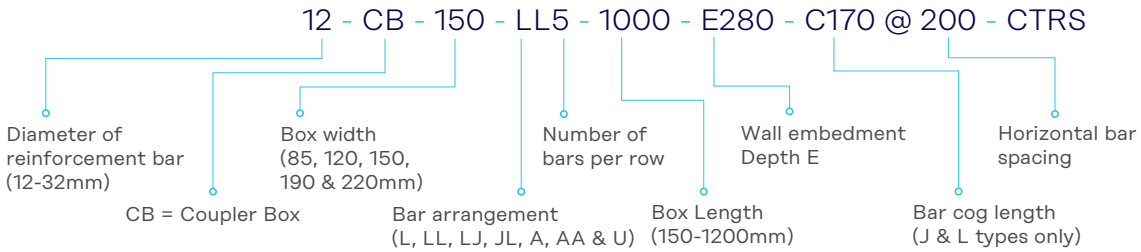

Bar Type

- Five standard Box Widths are available, including 85, 120, 150, 190 and 220mm.
- The thinner the box width, the more difficult it is to fit thicker bars, e.g., two rows of N20 bars will not fit into 120mm wide box.
- Standard casing lengths are 800mm, 1000mm and 1200mm. Specials can be made if necessary.
- Type U Coupler Box could be made with ± 3 mm tolerance in both transverse and longitudinal directions.

Ancon double row Coupler Boxes are designed to be installed at the top of the concrete pour. For conditions that require installation lower in the pour, the bars must be secured to the reinforcement cage or alternatively two single row boxes can be used.

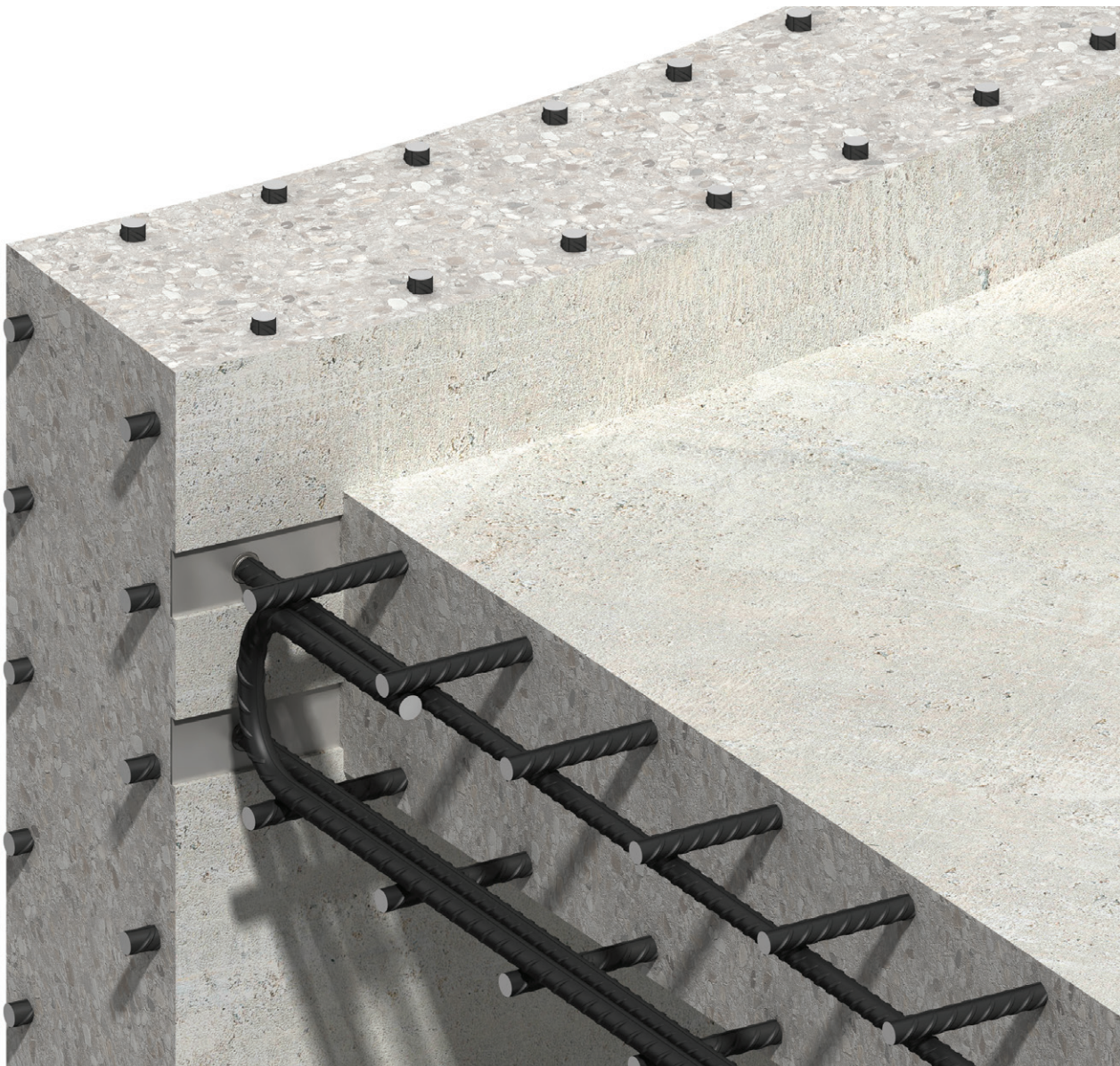



Ancon Coupler Box Dimensions

The following table gives the outer bar spacing values for double-row Coupler Boxes of various Box Widths. The recommended slab thickness for each Coupler Box is determined based on the outer bar spacing of the bars within the box, plus $c=30\text{mm}$ concrete clear cover per side. The values in the table also allow 5mm placement tolerance for the box. The 85mm boxes are only used as single-row type, with the bars sitting central within the box. The minimum slab thickness recommended for the 85mm box is 120mm.

Double Row Box Bar Spacing and Slab Range			
Bar Size	Box Width	Outer Bar Spacing B	Slab Thickness
N12	120	90	155-185
	150	120	185-225
	190	160	225-255
	220	190	255-300
N16	120	86	155-185
	150	120	185-225
	190	160	225-255
	220	190	255-300
N20 N24	120	80	145-175
	150	110	175-215
	190	150	215-245
	220	180	245-300

Schematic figure of a double-row LL-type Coupler Box within a slab-to-wall connection

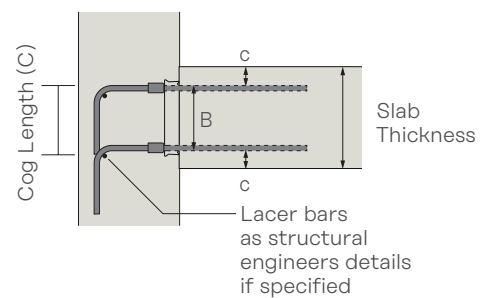

The below table shows the Minimum Embedment Depth and Minimum Cog Length for all boxes containing Type L and Type J bars due to manufacturing restrictions. The cog lengths comply with AS 3600:2018 Clause 13.1.2.7 and unless noted otherwise the minimum dimensions shown will be used. Minimum E values are due to manufacturing restrictions regarding grip of the bars within the machineries. By choosing to use cogged bars, the bar embedment leg could be reduced to half the development length required based on

AS 3600. The pin diameter values are in agreement with AS 3600:2018 Clause 17.2.3.3. Minimum Wall Thickness is based on 30mm concrete cover. Similar to Ancon Keyboxes and Ancon KSN Anchor Boxes, it is recommended to use the maximum embedment depth possible to increase the bar capacity. The couplers are installed flush with the back face of the box casing. Therefore, the Total Embedment Depth E is the fixed bar embedment leg + BT type A thread length + the 36mm Box Depth.

Minimum Dimensions for Types L, LL, LJ & JL				
Bar Size	Minimum Embedment (E)	Minimum Cog Length (C)	Pin Diameter	Minimum Wall Thickness
N12	128	170	60	160
N16	156	205	80	190
N20	186	245	100	220
N24	223	295	120	255
N28	290	345	140	320
N32	383	395	160	415

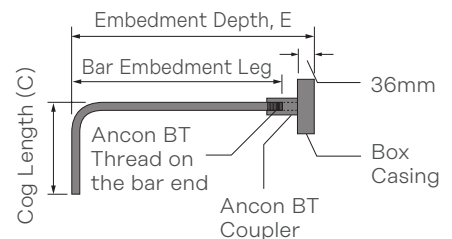

Reinforcement Continuity Systems

The following table provides the wall embedment depth E and slab embedment depth P for Ancon Coupler Boxes when straight bars are used on either side of the couplers (Box type A and AA). The starter bar length is chosen in a way that the bars can fully develop in accordance with the requirements of AS 3600. Starter bars in custom lengths are also available upon request. The slab embedment P would be the starter bar length minus the BT type A thread length, as the bar would be screwed into the BT coupler.

Wall Embedment Depth E for Types A & AA* Slab Embedment Depth P for all Types			
Bar Size	Starter Bar Part No.	Wall Embedment (E)	Slab Embedment (P)
N12	BTTHB12535	585	521
N16	BTTHB16700	756	680
N20	BTTHB201000	1060	976
N24	BTTHB241200	1266	1170
N28	BTTHB281400	1469	1367
N32	BTTHB321600	1672	1564

* Types A & AA boxes with bars longer than 1000mm will need to be assembled on site.

The centres S2 of the bars within the box are to be determined based on the design requirements of the project. Commonly the consecutive boxes are cast with about 30mm distance of each other. Therefore, the box edge distance S1 values are considered so that the spacing between the two adjacent bars from two consecutive boxes roughly matches the bar spacings S2. The following table shows possible configurations of Ancon Coupler Boxes. Custom lengths and configurations are also available on request.

Numbers of Bars per Row	Available Box Dimensions					
	Box Length					
	800		1000		1200	
	S1	S2	S1	S2	S1	S2
2	200	400	250	500	300	600
3	125	275	150	350	200	400
4	100	200	125	250	150	300
5	80	160	100	200	100	250
6	50	140	75	170	100	200
7	55	115	50	150	75	175
8	50	100	80	120	75	150
9			60	110	60	135
10			50	100	60	120
11					50	110
12					50	100

Single Row Box (Types A & L)

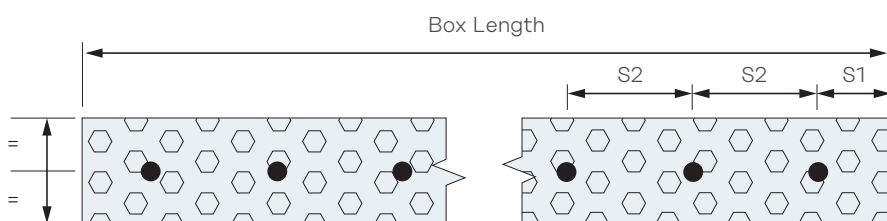

Double Row Box (Types LL, LJ, JL & AA)

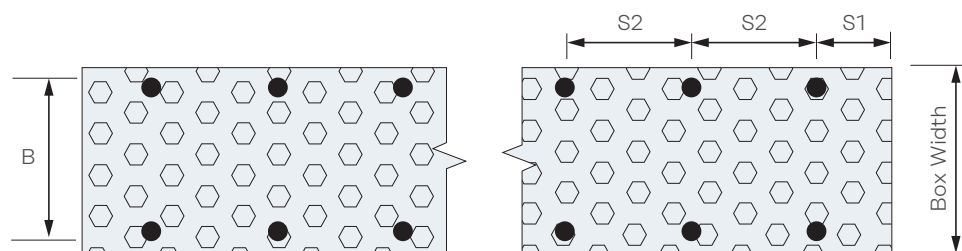

Installation Guidance on how to install Coupler Box system could be reviewed from the Ancon Coupler Box Installation Guide.

Lighthouse, VIC



Reinforcement Continuity Systems

Enquiry/Order Form - Ancon Coupler Box

Please provide product requirements and contact details. For orders please complete delivery details here:

Date	Order <input type="checkbox"/>	Enquiry <input type="checkbox"/>	Delivery Date
Company			Project
Address			Delivery Address
State	Post Code	State	Post Code
Contact			Site Contact
Tel			Tel
Email			Email

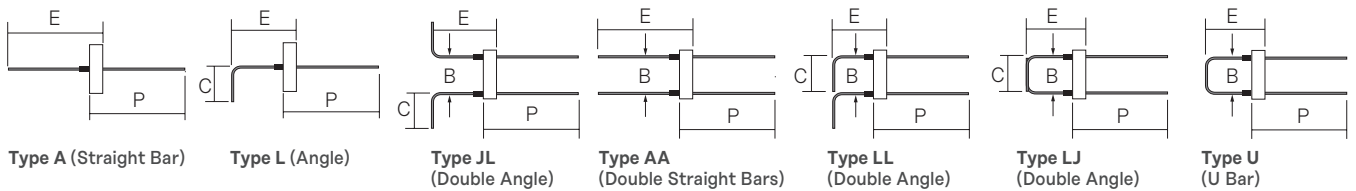

Coupler boxes placed deep in the pour can be subject to considerable forces that can deform the box and displace the bars. In these applications 2 single row type A or L boxes can be used to replace one type AA, JL, LL, LJ or U box.

Reference	Quantity	Bar Size	Box Width (mm)	Stirrup Type (see above)	Bar Spacing (mm)	Box Length (mm) (see note 1)	Embedment E (mm) (see table A)	Cog Length C (mm) (see table A)	Delivery Options of Starter Bar

Notes

- (1) Standard box lengths 800mm, 1000mm and 1200mm. Other lengths available on request.
- (2) Type U Coupler Box could be made with ±3mm tolerance in both transverse and longitudinal directions.

Table A - Minimum Dimensions for Coupler Boxes Containing Cogged Reinforcement

Bar Size	Minimum Embedment E (mm)	Minimum Cog Length C (mm)
N12	128	170
N16	156	205
N20	186	245
N24	223	295
N28	290	345
N32	383	395

Table B - Ancon Coupler Box Sizes and Dimensions

Box Width (mm)	Slab Thickness (mm)	Bar Size (mm)	Outer Bar Size B (mm)
85	≥100	N/A	N/A
120	155-185	12	90
	155-185	16	86
	145-175	20	80
	145-175	24	78
150	185-225	12	120
	185-225	16	116
	175-215	20	110
	175-215	24	108
	165-205	28	100
	165-205	32	96
190	225-255	12	160
	225-255	16	156
	215-245	20	150
	215-245	24	148
	205-235	28	140
	205-235	32	136
220	255-300	12	190
	255-300	16	186
	245-300	20	180
	245-300	24	178
	235-300	28	170
	235-300	32	166

Table C - Ancon BT Starter Bars

Rebar	Ancon BT Starter Bar	Part No.	P (mm)
N12	Ancon BT Starter Bar N12	BTTHB12535	521
N16	Ancon BT Starter Bar N16	BTTHB16700	680
N20	Ancon BT Starter Bar N20	BTTHB201000	976
N24	Ancon BT Starter Bar N24	BTTHB241200	1170
N28	Ancon BT Starter Bar N28	BTTHB281400	1367
N32	Ancon BT Starter Bar N32	BTTHB321600	1564

Email to orders.au@leviat.com

3 Ancon KSN Anchor Box Reinforcement Continuity System

If reinforcing bar congestion in the wall is a problem when installing the Coupler Box, an alternative anchor system is available. The KSN Anchor Box system works in exactly the same way as a Coupler Box; however instead of L-bars cast into the wall, this box uses headed anchors conforming to the requirements of AS 3600:2018. A BT-threaded continuation bar is used in the same way as the starter bars for Coupler Box system.

Ancon KSN Anchor Box comprises of KSN anchors attached to the same galvanised steel casing used for Keybox and Coupler Box system. The anchors are held in place by use of metal bolts which also act as protection of the internal thread of the anchor. The casing

is enclosed by a protective cover steel lid and also sealed from the sides by two polystyrene blocks to prevent ingress of concrete. All Ancon BT starter bars to be used with KSN Anchor Boxes are manufactured from ACRS approved Grade 500N rebars with minimum yield strength of 500MPa and minimum uniform elongation A_{gt} 5% which meet the requirements of AS/NZS 4671:2019. The back of the box is profiled providing a key with adjacent concrete and resistance to shear loads, and the casing has short sides to keep steel well back allowing for concrete clear cover.

Ancon KSN Anchors are machined from tough, high reliability, hot forged Cr-Mo alloy steel, with minimum 15% elongation, to form a blank that is subsequently hot

forged to form the head. There are eight standard anchors in the KSN range with different lengths and sizes to suit the requirements of most applications. KSN Anchor Boxes are available up to 20mm bar size (N12-N20 bars), as larger KSN anchors are too heavy and might result in the box casing buckling issue.

This product has undergone extensive testing and tabulated performance data for commonly used anchor configurations can be found in the Ancon KSN Anchors brochure. Creating full strength of a mechanical splice, Ancon KSN anchors can provide capacities exceeding the capacity of the reinforcement bar and thus form a ductile system that fulfils the requirements of AS 3600:2018.

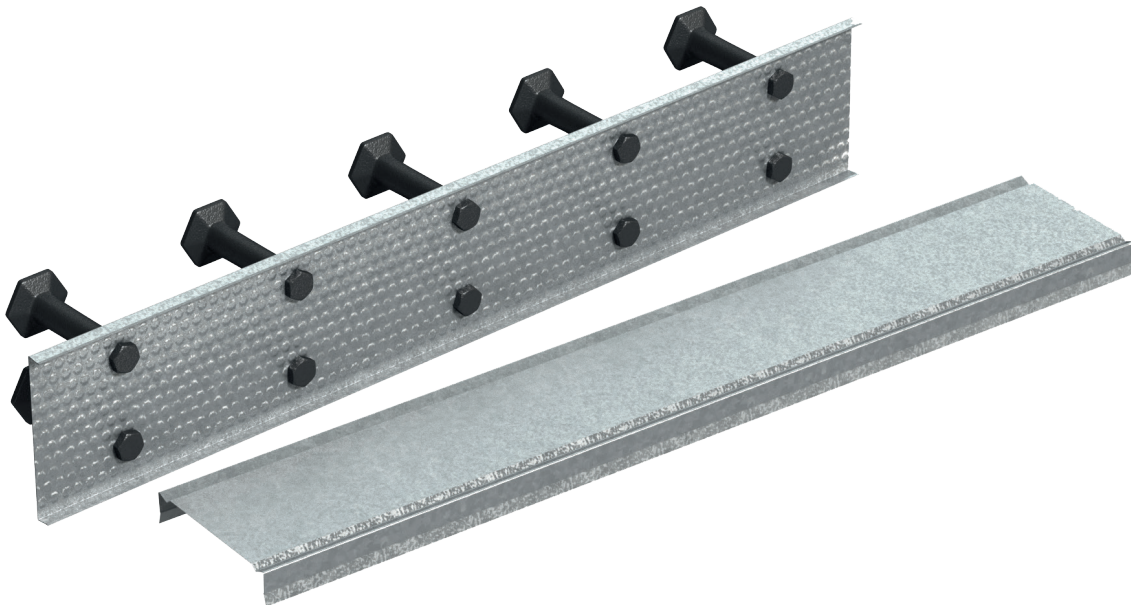

Reinforcement Continuity Systems

Typical Applications for KSN Anchor Box

Similar to other reinforcement continuity systems, the typical applications for Ancon KSN Anchor Boxes also include slab-to-wall, wall-to-wall and slab-to-slab joints. The boxes could be cast in either horizontally or vertically within the concrete.

Utilizing the Ancon KSN Anchor Box system offers many benefits over conventional joint construction, including:

- Replaces cogged or hooked bars and minimizes the congestion within the concrete
- Enhanced performance in either direct tensile applications or moment connections
- Simplification of formwork design and removal of the need to drill shuttering
- Ideal to simplify concrete slab-to-wall construction joints and accelerate the speed of construction
- Quicker, easier and above all, safer solution compared to traditional methods
- Available in short lengths to ease onsite handling
- Multiple types and profile heights available to suit all applications.

Available types

Ancon KSN Anchor Boxes are available with all N12-N20 reinforcement bar sizes. Two types are available based on the arrangement of the anchors within the box, type A indicates a box with a single row of anchors, and type AA a box with a double row.

Similar to Ancon BT couplers, Ancon KSN anchors also work with the proprietary BT threading system with the thread size larger than the bar itself to provide a ductile bar break splice with failure always happening on the bars far from the connection. The information on Ancon BT Starter Bars to be used as continuation bars for KSN Box system could be reviewed from page 31.

Single row boxes

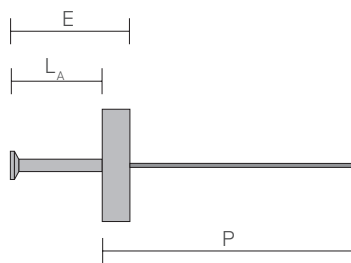

Type A

Double row boxes

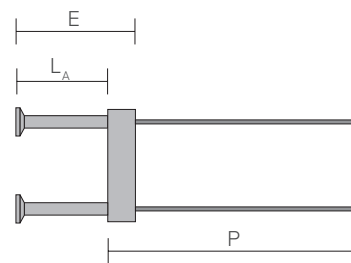

Type AA

E = Total Embedment Depth computed from the front of the box casing
 L_A = KSN Anchor Length
 P = Starter bar Lap Length computed from inside of the box casing



Ancon KSN Anchor Box Identification

Each KSN anchor can come in up to three lengths (Short, Medium and Long) which also determines the resultant wall embedment depth (E). Based on the requirements of AS 3600, the minimum spacing required to achieve the maximum anchor tensile capacity is three times the effective anchor depth h_{eff} , so that the concrete cone of influence could be fully developed for each anchor.

The following nomenclature could be used to specify the KSN Anchor Box system:

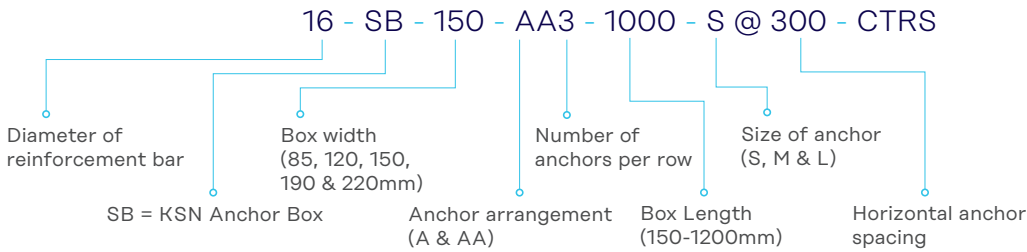

- Five standard Box Widths are available, including 85, 120, 150, 190 and 220mm.
- For slabs thicker than 200mm, it is highly recommended to use two or more rows of 85mm wide boxes to avoid box buckling under concrete pressure.
- The thinner the box width, the more difficult it is to fit thicker bars, e.g., two rows of N20 bars will not fit into 120mm wide box.
- Standard casing lengths are 800mm, 1000mm and 1200mm. Special boxes with lengths from 150mm can be made upon request.

Ancon double row KSN Anchor Boxes are designed to be installed at the top of the concrete pour. For conditions that require installation lower in the pour, the bars must be secured to the reinforcement cage or alternatively two single row boxes can be used.

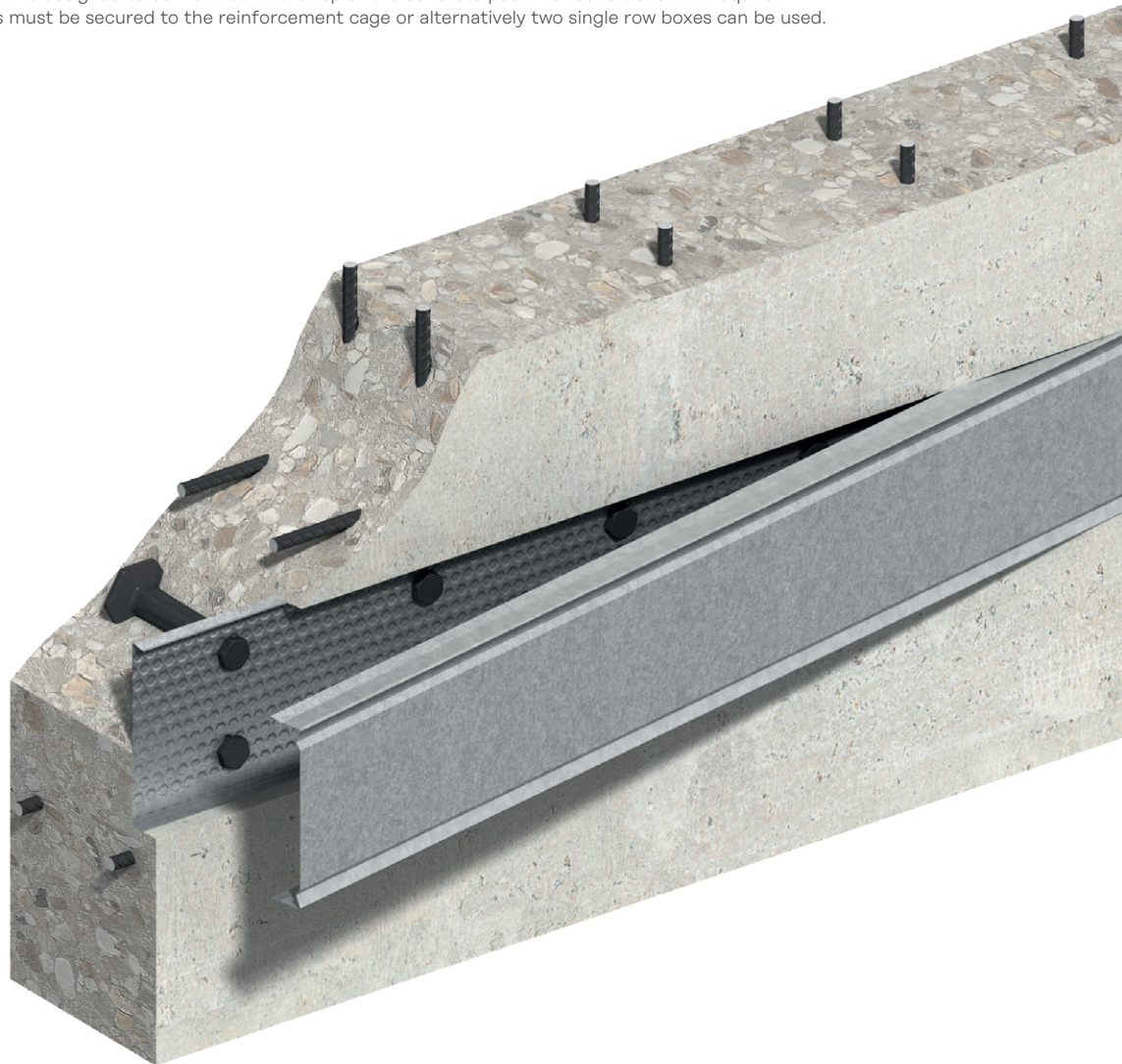



Ancon KSN Anchor Box Dimensions

The following table gives the outer bar spacing values for double-row KSN Anchor Boxes of various Box Widths. The recommended slab thickness for each box is determined based on the outer bar spacing of the bars within the box, plus $c=30\text{mm}$ concrete clear cover per side and also 5mm tolerance. The 85mm boxes are only used as single-row type, with the anchors/bars sitting central within the box. The minimum slab thickness recommended for the 85mm box is 120mm.

Double Row Box Bar Spacing and Slab Range			
Bar Size	Box Width	Outer Bar Spacing B	Slab Thickness
N12	120	90	155-185
	150	120	185-225
	190	160	225-255
	220	190	255-300
N16	120	86	155-185
	150	116	185-225
	190	156	225-255
N20	220	186	255-300
	150	110	175-215
	190	150	215-245
	220	180	245-300

The below table shows the typical dimensions for KSN Anchor Box applications. Minimum Wall Thickness is based on 30mm concrete cover. Similar to the case for Keyboxes and Coupler Boxes, the higher the embedment depth

the better for avoiding the pullout failure and also concrete cone failure. The KSN anchors are installed flush with the back face of the box casing. Therefore, the Total Embedment Depth E would be the anchor length plus 36mm box recess.

Schematic figure of a double-row AA-type KSN Anchor Box within a slab-to-wall connection

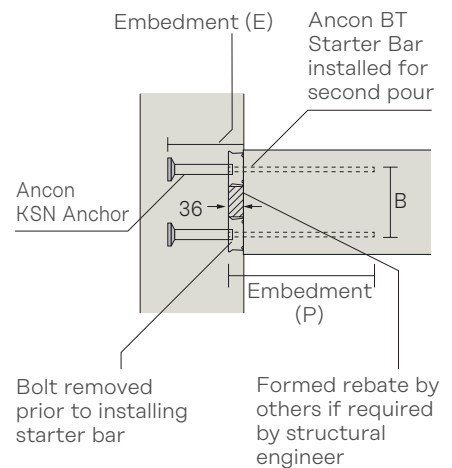

Dimensions for KSN Anchor Boxes			
Anchor Part No.	Anchor Length L_A	Total Embedment E	Minimum Wall Thickness
KSN12S	115	151	185
KSN12M	150	186	220
KSN16S	130	166	200
KSN16M	160	196	230
KSN16L	190	226	260
KSN20S	150	186	220
KSN20M	190	226	260
KSN20L	230	266	300

The edge distance S1 and the centres S2 values would be similar to those given for Coupler Boxes. Custom lengths and configurations are also available on request.

Numbers of Bars per Row	Available Box Dimensions					
	Box Length					
	800		1000		1200	
	S1	S2	S1	S2	S1	S2
2	200	400	250	500	300	600
3	125	275	150	350	200	400
4	100	200	125	250	150	300
5	80	160	100	200	100	250
6	50	140	75	170	100	200
7	55	115	50	150	75	175
8	50	100	80	120	75	150
9			60	110	60	135
10			50	100	60	120
11					50	110
12					50	100

Reinforcement Continuity Systems

Single Row Box (Type A)

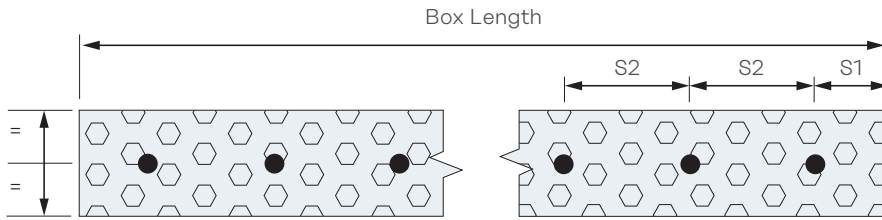

Double Row Box (Type AA)

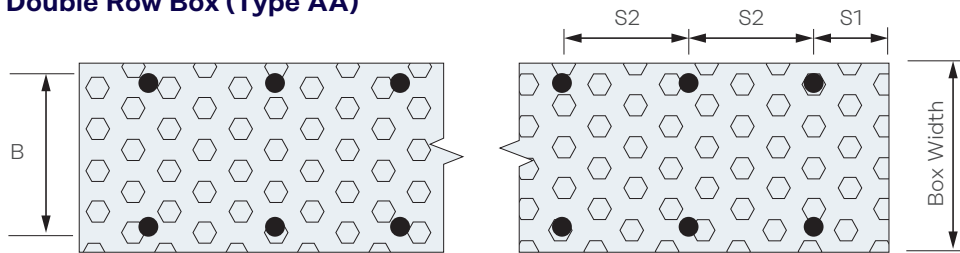

Installation Guidance on how to install KSN Anchor Box system could be reviewed from the Ancon KSN Anchor Box Installation Guide.

AS Apartments, QLD



Reinforcement Continuity Systems

Enquiry/Order Form - Ancon KSN Anchor Box

Please provide product requirements and contact details. For orders please complete delivery details here:

Date	Order <input type="checkbox"/>	Enquiry <input type="checkbox"/>	Delivery Date
Company			Project
Address			Delivery Address
State	Post Code		State
Contact			Site Contact
Tel			Tel
Email			Email

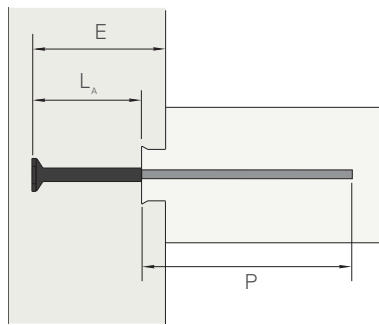

Type A

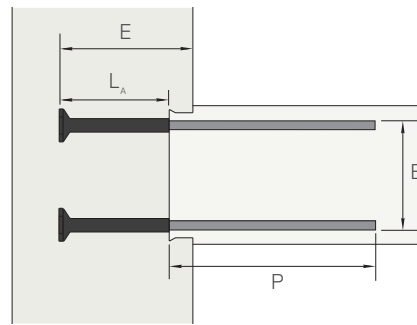

Type AA

KSN Anchor Boxes placed deep in the pour can be subject to considerable forces that can deform the box and displace the anchors. In these applications 2 single row type A boxes can be used to replace one type AA box.

Reference (see Table A)	Quantity	Box Width (mm)	Type (see above)	Box Length (mm) (see note 1)	Anchor Centres (mm)	Starter Bar Length (mm) (see table C)	Delivery Options of Starter Bar

Notes

(1) Standard box lengths 800mm, 1000mm and 1200mm. Other lengths available on request.

Table A - Total Embedment for Ancon KSN Box

KSN Anchor	Anchor Length L _A (mm)	Total Embedment* E (mm)	Minimum Wall Thickness (mm)
KSN12-S	115	151	185
KSN12-M	150	186	220
KSN16-S	130	166	200
KSN16-M	160	196	230
KSN20-L	190	226	160
KSN20-S	150	186	220
KSN20-M	190	226	260
KSN20-L	230	266	300

*Total embedment is the sum of the anchor length and the 36mm box depth.

Table B - Ancon Standard KSN Box Sizes and Dimensions

Box Width (mm)	Slab Thickness* (mm)	Bar Size (mm)	Outer Bar Size B (mm)
85	N/A	N/A	N/A
120	155-185	12	90
	155-185	16	86
150	185-225	12	120
	185-225	16	116
	175-215	20	110
190	225-255	12	160
	225-255	16	156
	215-245	20	150
	255-300	12	190
220	255-300	16	186
	245-300	20	180

* Slab thickness is based on 30mm concrete cover and 5mm tolerance.

** KSN20 anchors only available for Box Widths of 150mm and above.

Table C - Ancon BT Starter Bars

Rebar	Ancon BT Starter Bar	Part No.	P (mm)
N12	Ancon BT Starter Bar N12	BTTHB 12535	521
N16	Ancon BT Starter Bar N16	BTTHB 16700	680
N20	Ancon BT Starter Bar N20	BTTHB 201000	976

Other lengths available on request.

Email to orders.au@leviat.com

Reinforcement Continuity Systems

4

Ancon BT Starter Bars

Leviat provides standard starter bars to be used as continuation bars for Ancon Coupler Boxes and Ancon KSN Anchor Boxes. The Ancon BT Starter Bars receive appropriate BT thread matching the internal thread on the corresponding coupler or KSN anchor.

The Ancon BT Threading System is a bar-break system, which provides a connection capacity that exceeds the

capacity of the connected reinforcement bar. Connections that use the Ancon BT proprietary thread are superior to metric threaded bars, where the capacity of the connection will be lower compared to the bar capacity.

The Table below shows details of the Ancon BT Starter Bars. The bar lengths of the standard bars are chosen so that they can develop the full bar capacity

as per requirements of AS 3600:2018. Custom bars are also available upon request. The slab embedment P is the starter bar length minus the BT type A thread length, as the bar would be screwed into the Ancon BT Coupler or the Ancon KSN Anchor.

Ancon BT Starter Bar Dimensions			
Bar Size	Starter Bar Part No.	Starter Bar Length	Slab Embedment (P)
N12	BTTHB12535	535	521
N16	BTTHB16700	700	680
N20	BTTHB201000	1000	976
N24	BTTHB241200	1200	1170
N28	BTTHB281400	1400	1367
N32	BTTHB321600	1600	1564

Type A Ancon Coupler Box

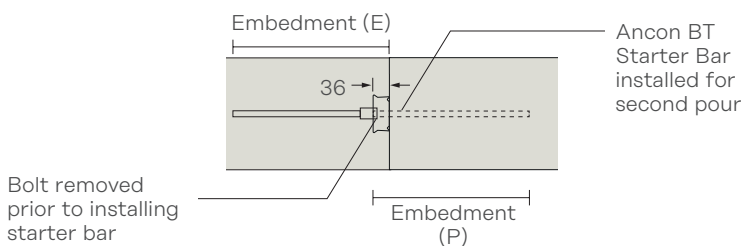

Type A Ancon KSN Anchor Box

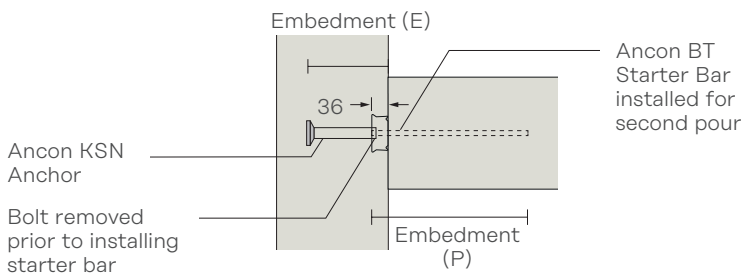



Reinforcement Continuity Systems

Other Ancon Products

Masonry Support Systems

Masonry cladding on concrete or steel frames is normally supported from stainless steel support systems. Ancon MDC Systems create a continuous angle to support the outer leaf of masonry. Ancon Individual Brackets support masonry features such as curves and arches. A full design service is available to specifiers and users of Ancon systems.



MBT Mechanically Bolted Couplers

MBT couplers offer a convenient means of joining bars without the need for bar end preparation to suit BT couplers. The bars are supported within the coupler on two serrated saddles and are locked in place by a series of special lockshear bolts. Bar rotation is not required.



Shear Load Connectors

Ancon DSD and ESD Shear Load Connectors are used to transfer shear across expansion and contraction joints in concrete. They are more effective at transferring load and allowing movement to take place than standard dowels, and can be used to eliminate double columns at structural movement joints in buildings. A 'Lockable' dowel is also available for temporary movement joints in post-tensioned concrete frames.



Punching Shear Reinforcement

Ancon Shearfix is used within a slab to provide additional reinforcement from punching shear around columns. The system consists of double-headed steel studs welded to flat rails and is designed to suit the load conditions and slab depth at each column using our free calculation software.



Channel and Bolt Fixings

Leviat offers a wide range of channels and bolts in order to fix stainless steel masonry support, restraints and windposts to structural frames. Cast-in channels and expansion bolts are used for fixing to the edges of concrete floors and beams. A range of stainless steel set screws and self-drill self-tap screws are designed to fix to steel frames.



Special Fabrications

Leviat is an ASSDA accredited specialist fabricator and has a wealth of experience in working with a variety of material grades. High integrity steel components are supplied to a wide range of industries including Civil Engineering, Building, Infrastructure, Water Treatment, Nuclear and Mining.



© Thiess Energy Australia



Leviat[®]

Innovative engineered products and construction solutions that allow the industry to build safer, stronger and faster.



Contact Leviat locally

For more information on the products featured here, please contact Leviat:

For more information on the following products, please contact:

Masonry, Structural and Precast Concrete products:

1300 304 320
info.ancon.au@leviat.com
Ancon.com.au

Concrete Floor Jointing products:

1800 335 215
info.connolly.au@leviat.com
Connollykeyjoint.com
info.isedio.au@leviat.com
Isedio.com.au

Remedial Masonry products:

1300 667 071
info.helifix.au@leviat.com
Helifix.com.au

General Enquiries

T: 1300 304 320
Leviat.com

Sales Offices and Production

New South Wales, Sydney

Unit A, 1 Heinrich Close,
Eastern Creek | Sydney
NSW 2766

Queensland

17 Goodman Place
Murarrie | Brisbane
QLD 4172

New South Wales, Casino

10 Irving Drive
Casino
NSW 2470

South Australia

Unit 2/35-37 Maxwell Road
Laverton North | Adelaide
SA 5095

Victoria

9/63-69 Pipe Road
Laverton North | Melbourne
VIC 3026

Western Australia

18 Tennant Street
Welshpool | Perth
WA 6106

Contact Leviat worldwide

Australia

Unit A, 1 Heinrich Close,
Eastern Creek, Sydney, NSW 2766
Tel: +61 - 2 8808 3100
Email: info.au@leviat.com

Austria

Leonard-Bernstein-Str. 10 Saturn
Tower, 1220 Wien
Tel: +43 - 1 - 259 6770
Email: info.at@leviat.com

Belgium

Industrielaan 2
1740 Ternat
Tel: +32 - 2 - 582 29 45
Email: info.be@leviat.com

China

Room 601 Tower D,
Vantone Centre
No. A6 Chao Yang Men Wai Street
Chaoyang District
Beijing P.R. China 100020
Tel: +86 - 10 5907 3200
Email: info.cn@leviat.com

Czech Republic

Business Center Šafránková
Šafránková 1238/1
155 00 Praha 5
Tel: +420 - 311 - 690 060
Email: info.cz@leviat.com

Finland

Vädursgatan 5
412 50 Göteborg / Sweden
Tel: +358 (0)10 6338781
Email: info.fi@leviat.com

France

6, Rue de Cabanis
FR 31240 L'Union
Toulouse
Tel: +33 - 5 - 34 25 54 82
Email: info.fr@leviat.com

Germany

Liebigstrasse 14
40764 Langenfeld
Tel: +49 - 2173 - 970 - 0
Email: info.de@leviat.com

India

309, 3rd Floor
Orion Business Park
Ghodbunder Road
Kapurbawdi, Thane West,
Thane, Maharashtra 400607
Tel: +91 - 22 2589 2032
Email: info.in@leviat.com

Italy

Via F.lli Bronzetti 28
24124 Bergamo
Tel: +39 - 035 - 0760711
Email: info.it@leviat.com

Malaysia

28 Jalan Anggerik Mokara 31/59
Kota Kemuning,
40460 Shah Alam Selangor
Tel: +603 - 5122 4182
Email: info.my@leviat.com

Netherlands

Oostermaat 3
7623 CS Borne
Tel: +31 - 74 - 267 14 49
Email: info.nl@leviat.com

New Zealand

PO Box 33232
Barrington
Christchurch 8244
Tel: +64 - 3 376 5205
Email: info.nz@leviat.com

Norway

Vestre Svanholmen 5
4313 Sandnes
Tel: +47 - 51 82 34 00
Email: info.no@leviat.com

Philippines

2933 Regus, Joy Nostalg,
ADB Avenue, Ortigas Center
Pasig City
Tel: +63 - 2 7957 6381
Email: info.ph@leviat.com

Poland

Ul. Obornicka 287
60-691 Poznań
Tel: +48 - 61 - 622 14 14
Email: info.pl@leviat.com

Singapore

14 Benoi Crescent
Singapore 629977
Tel: +65 - 6266 6802
Email: info.sg@leviat.com

Spain

Polígono Industrial Santa Ana
c/ Ignacio Zuloaga, 20
28522 Rivas-Vaciamadrid
Tel: +34 - 91 632 18 40
Email: info.es@leviat.com

Sweden

Vädursgatan 5
412 50 Göteborg
Tel: +46 - 31 - 98 58 00
Email: info.se@leviat.com

Switzerland

Grenzstrasse 24
3250 Lyss
Tel: +41 (0)800 22 66 00
Email: info.ch@leviat.com

United Arab Emirates

RA08 TB02, PO Box 17225
JAFZA, Jebel Ali, Dubai
Tel: +971 (0)4 883 4346
Email: info.ae@leviat.com

United Kingdom

President Way,
President Park,
Sheffield S4 7UR
Tel: +44 - 114 275 5224
Email: info.uk@leviat.com

USA / Canada

6467 S Falkenburg Road
Riverview, FL 33578
Tel: (800) 423-9140
Email: info.us@leviat.us

For countries not listed
Email: info@leviat.com

Notes regarding this document

© Protected by copyright. The information in this publication is based on state-of-the-art technology at the time of publication. In every case, project working details should be entrusted to appropriately qualified and experienced persons. Leviat shall not accept liability for the accuracy of the information in this document or for any printing errors. We reserve the right to make technical and design changes at any time. With a policy of continuous product development, Leviat reserves the right to modify product design and specification at any time.

Leviat®

Imagine. Model. Make.

Leviat.com