

Structural Connections  
Reinforcing Bar Couplers

**Leviat®**

## **Ancon Lockable Dowels and Locking Pins**

for Temporary Movement Joints in Post-Tensioned Concrete

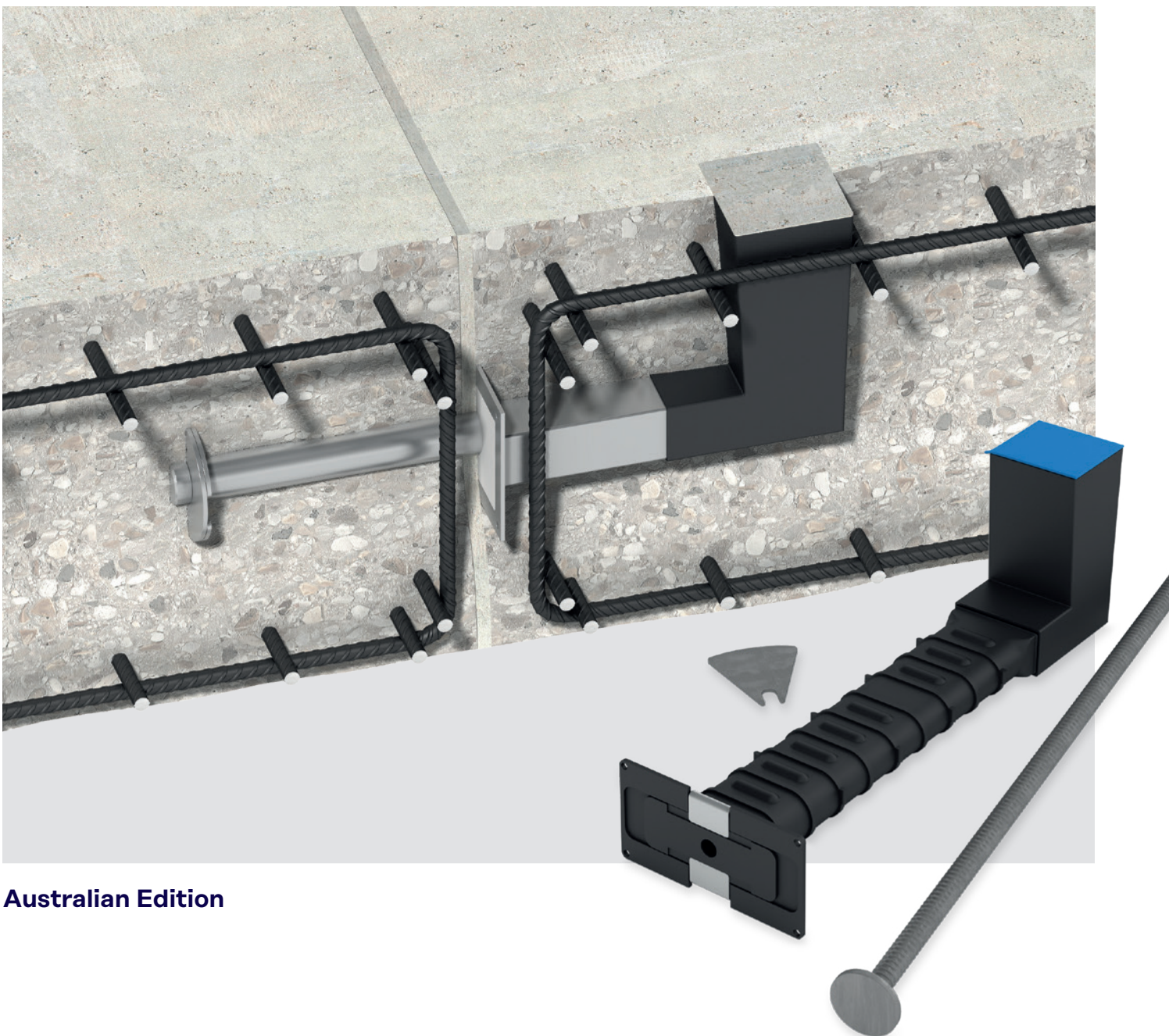

**Australian Edition**

Imagine. Model. Make.

# Leviat

We imagine, model and make engineered products and innovative construction solutions that help turn architectural visions into reality and enable our construction partners to build better, safer, stronger and faster.

**Leviat is a world leader in connecting, fixing, lifting and anchoring technology.**

From the build of new schools, hospitals, homes and infrastructure, to the repair and maintenance of heritage structures, our engineering skills are making a difference around the world.

We provide technical design assistance at every stage of a project, from initial planning to installation and beyond.

Our technical support services range from simple product selection through to the development of a fully customised project-specific design solution.

Every promise we make locally, has the commitment and dedication of our global team behind it. We employ almost 3,000 people at 60 locations across North America, Europe and Asia-Pacific, providing an agile and responsive service worldwide.



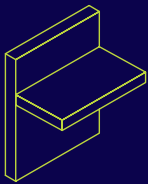
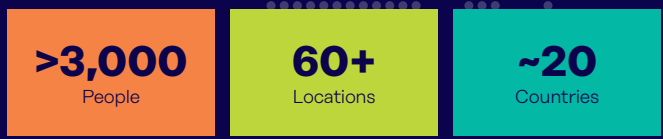

### Structural Connections

Systems to form robust, efficient connections, and continuity of concrete reinforcement as necessary, between walls, slabs, columns, beams and balconies, providing structural integrity as well as enhanced thermal and acoustic performance.

- Insulated balcony connectors
- Reinforcing bar couplers
- Concrete Connections
- Reinforcement continuity systems
- Punching shear reinforcement
- Shear load connectors
- Floor Joint Systems
- Precast / Reinforced Columns
- Infrastructure Products
- Precast Connections
- Acoustic dowels and bearings
- Prestress

### Other areas of expertise:

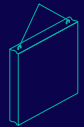

#### Lifting & Bracing

Systems for the safe and efficient transportation, lifting and temporary bracing of cast concrete elements and tilt-up panels before permanent structural connections are made.

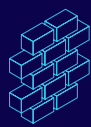

#### Façade Support & Restraint

Systems for the safe and thermally-efficient fixing of the external building envelope, including brick and natural stone, insulated sandwich panels, curtain walling and suspended concrete façades, and also the repair and strengthening of existing masonry installations.

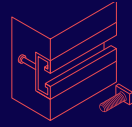

#### Anchoring & Fixing

Systems for fixing secondary fixtures to concrete, including anchor channels, bolts and inserts; also tension rod systems for roofs and canopies.



#### Formwork & Site Accessories

Non-structural accessories that complement our engineered solutions and help keep your construction environment operating safely and efficiently, including moulds for casting standard and special concrete elements and construction essentials such as reinforcing bar spacers.

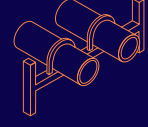

#### Industrial Technology

Mounting channels, pipe clamps and other versatile framing systems that provide safe fixing in a wide range of industrial applications.

### Leviat product ranges:

Ancon | Aschwanden | Connolly | Halfen | Helifix | Isedio | Meadow Burke | Modersohn | Moment | Plaka | Scaldex | Thermomass

# Ancon Lockable Dowels and Locking Pins

## Contents

The 'Lockable' Range	4
Advantages & Applications	4-5
Range of Lockable Dowels & Locking Pins	6-8
Typical Combined Applications	9
Performance Data, Spacings, Reinforcement Details & Dimensions	10-15
Installation Procedures	16-17
Projects	18
Other Ancon Products	18

## The 'Lockable' Range

Ancon Lockable Dowels and Ancon Locking Pins are unique, patented products. They were developed by Leviat for use at temporary movement joints, most commonly found in post-tensioned concrete frames. They allow initial shrinkage of the concrete to take place and are then locked in position, by mechanical and chemical means, to prevent further movement taking place.

They also provide many advantages over the site-assembled arrangement of carbon steel reinforcing bar, galvanised or plastic ducting, vent tubes and a non-specific grout, which is sometimes used by contractors.

Ancon Lockable Dowels transfer shear load in both their locked and unlocked state which reduces slab propping times and accelerates the rate of construction.

Ancon Locking Pins are ideal for applications where there is little or no shear load.

When used together, or in combination with other Ancon shear load connectors these unique 'lockable' products provide a cost-effective and practical fixing solution. Contact us with your project details.



The performance of site assembled systems can be unreliable

Australia Patent No. 2008294503  
 New Zealand Patent No. 583887  
 US Patent No. 8209933  
 Singapore Patent No. 159760  
 South Africa Patent No. 2010/01651  
 Other patents pending

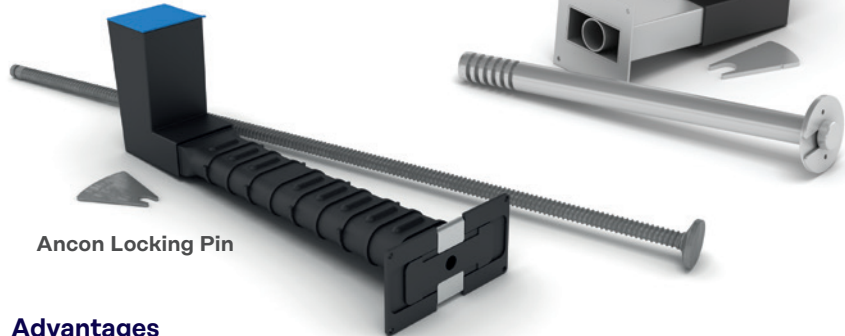

Ancon Locking Pin

## Advantages

The use of Lockable Dowels can save a significant amount of time and materials over other construction methods. Concrete shrinkage has traditionally been accommodated by leaving gaps in the slab called 'pour strips' or 'closure strips'. These strips are filled once movement has stabilised, however until they are filled the slabs must be propped, restricting site access and delaying site progress. Gaps in the slab also create a trip hazard for site workers, use additional formwork and can leave the soffit face marked.

Lockable Dowels improve site access, minimise formwork requirements and accelerate the rate of construction. With a Lockable Dowel, there is less requirement for the slabs to be propped or a support corbel to be constructed, as shear load is transferred by the dowel. The time saved by early removal of slab props can be significant.

In addition, engineers have found the Ancon Lockable Dowel to be the preferred design solution for pin-ended joints. Although it is customary for practical reasons to use U-bars or other rebar continuity systems at these connections, these options do not truly act as hinges and so rotation of the slab under load can induce cracking at the wall-to-slab interface with potential integrity issues.

## Ancon Lockable Dowel

The Lockable Dowel is closer to a true pin-ended joint and, being manufactured from stainless steel, provides additional corrosion protection over systems using carbon steel reinforcement.

The design capacities shown on page 10 are backed by independent test data and the unique void former allows inspection of the dowel before the joint is locked.

Standard Ancon systems are available for use at slab joints and retaining / core walls.

The design capacities shown on page 10 are backed by independent test data and the unique void former allows inspection of the dowel before the joint is locked.

Standard Ancon systems are available for use at slab joints and retaining / core walls.

- ✓ **Eliminate pour strips**
- ✓ **Reduce propping times**
- ✓ **Reduce formwork**
- ✓ **Improve site access**
- ✓ **Faster, safer construction**
- ✓ **Proven performance**
- ✓ **Simple installation**
- ✓ **Guaranteed alignment allows movement**
- ✓ **Allow inspection before locking**



Pour Strips restrict site access, cause a trip hazard and delay progress on site



The Lockable Dowel eliminates the need for Pour Strips, accelerating the speed of construction and improving site safety

## Applications

In most cases, Ancon Lockable Dowels can be used to replace pour strips at temporary movement joints in post-tensioned concrete frames. Standard Ancon systems are available for use at slab joints and retaining / core walls.

"The consulting design engineer wanted a one metre wide pour strip to be left open for 90 days which wasn't acceptable to Hansen Yuncken. Using the Ancon Lockable Dowel system allowed earlier formwork stripping and work to continue with our services, thereby reducing overall construction time."

**Brent Courtney, Senior Site Manager, Hansen Yuncken QLD**

"The Lockable Dowel is a very clean system. If you have encountered pour strips before, the Lockable Dowel is a no-brainer."

**Mahmoud Farawi, Skanska USA**



### Slab-to-Slab

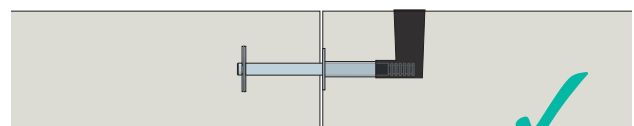
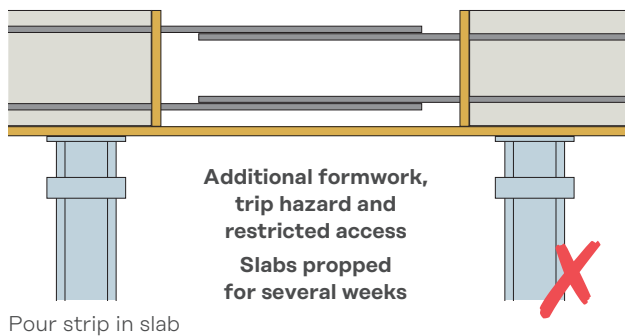

Ancon Lockable Dowel

Minimal formwork  
Improved site access  
Reduced propping time

### Slab-to-Wall

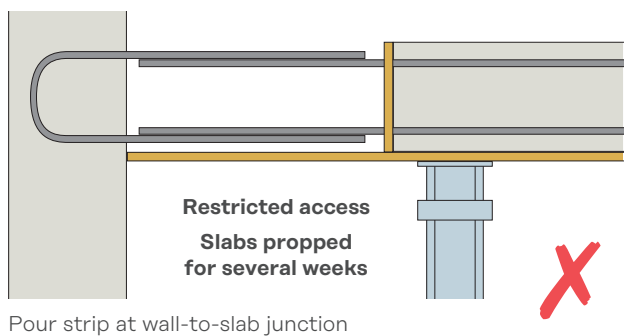

Ancon Lockable Dowel

Improved site access  
Reduced propping time

### Slab-to-Slab

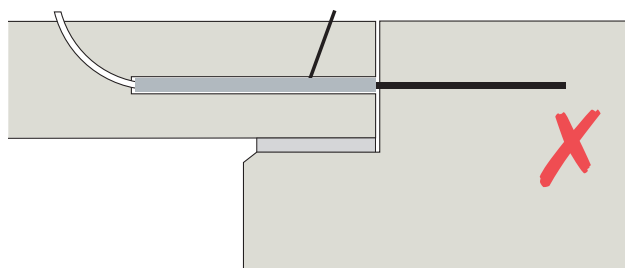

Various site-assembled components

Unreliable performance  
Blind installation

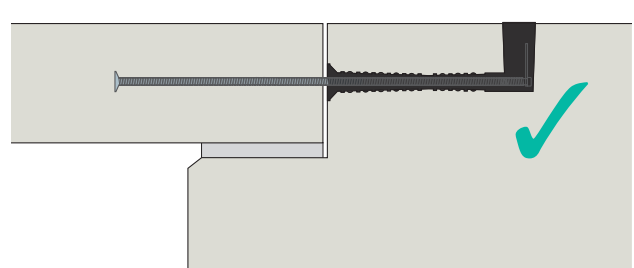

Ancon Locking Pin

Proven performance  
Controlled installation

# Ancon Lockable Dowels and Locking Pins

## Range of Ancon Lockable Dowels

Ancon Lockable Dowel allows initial shrinkage of the concrete to take place and then, after a pre-determined time period (generally 3-4 weeks), is locked in position with a mechanical plate and a controlled amount of epoxy resin. The range comprises three products; ESDQ-L20, HLDQ-L30 and ESDQ-L20W.

### Slab-to-Slab Lockable Dowels

#### Ancon ESDQ-L20

The dowel component is manufactured from 30mm diameter stainless steel; one end features two fixed overlapping anchor discs and the other has a series of grooves to accept the Locking Plate. The cylindrical sleeve which accepts the dowel component is contained within a box-section to allow lateral, longitudinal and some rotational movement. The epoxy resin is poured into the L-shaped void former. This product has a design capacity of up to 71kN. See pages 10-14 for full technical details.



Reinforcement being located around ESDQ-L20 Sleeves

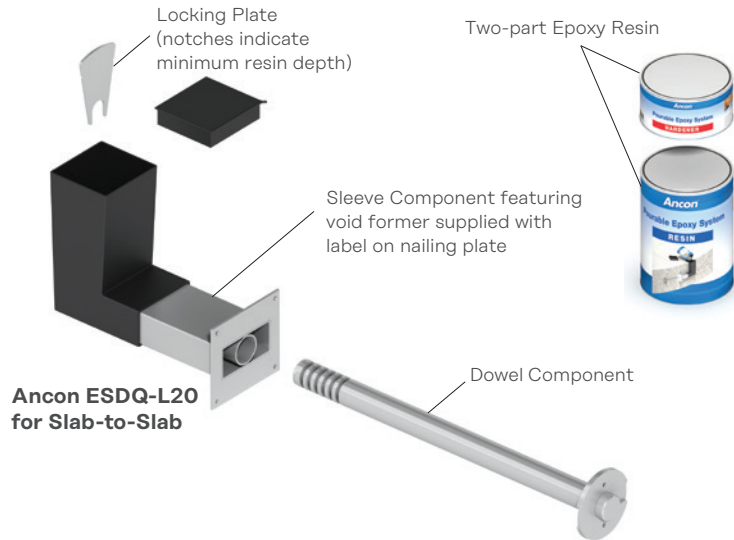

Ancon ESDQ-L20 for Slab-to-Slab

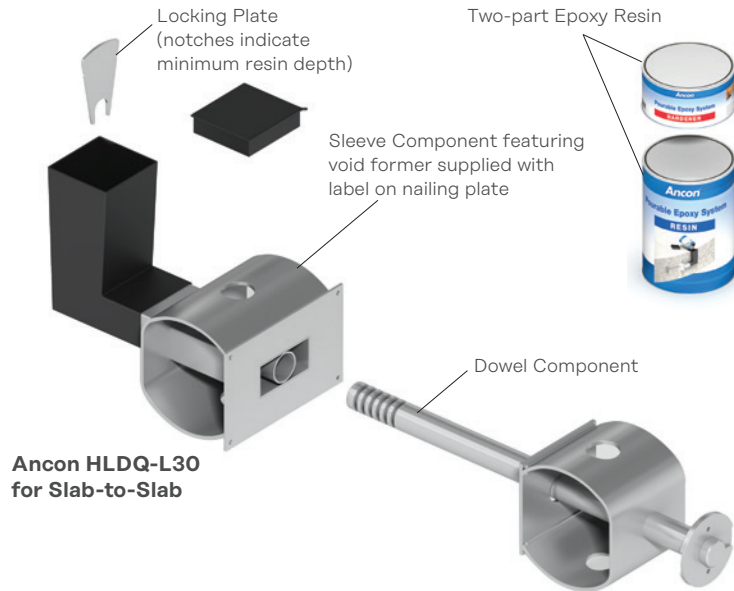

Ancon HLDQ-L30 for Slab-to-Slab

#### Ancon HLDQ-L30

The HLDQ-L30 is a high load Lockable Dowel with a design capacity of up to 136kN. See pages 10-14 for full technical details.



HLDQ-L30 Sleeve nailed to formwork

#### Example Specification Clause

Delete/Amend blue text as appropriate

<Ancon ESDQ-L20 or Ancon HLDQ-L30> lockable shear load connector comprising dowel, sleeve and locking components to be installed at the temporary movement joint between two slabs. Product to be positioned at <insert centres>mm horizontal centres at <the centre line of the slab or XXXmm from the top of the slab>. The dowel is to be locked in position after <insert time period> using the locking plate and resin supplied. System should be installed in accordance with Ancon lockable dowel instructions and engineer's drawings.

## Slab-to-Wall Lockable Dowel

### Ancon ESDQ-L20W

The dowel component is manufactured from 30mm diameter stainless steel, but is shorter than the ESDQ-L20 dowel. One end of the dowel is designed to fix into the stainless steel Ancon SKS24 Threaded Anchor cast into the face of the concrete and the other end features a series of grooves to accept the Locking Plate. The sleeve component is the same as used in the ESDQ-L20. See pages 10-14 for full technical details.



Sleeve pushed over dowel component at core wall

#### Example Specification Clause

Delete/Amend blue text as appropriate

Ancon ESDQ-L20W lockable shear load connector comprising dowel, sleeve, threaded anchor and locking components to be installed at the temporary movement joint between slab and wall. Product to be positioned at <insert centres>mm horizontal centres at <the centre line of the slab or XXXmm from the top of the slab>. The dowel is to be locked in position after <insert time period> using the locking plate and resin supplied. System should be installed in accordance with Ancon lockable dowel instructions and engineer's drawings.

#### Epoxy Resin

Each dowel is locked after a pre-determined time period (generally 3-4 weeks) with a high quality, two-part epoxy resin. The resin is mixed and poured into the L-shaped void former. Each dowel requires 1,500g of resin. Users are required to take note of storage conditions and mixing instructions given on the packaging.

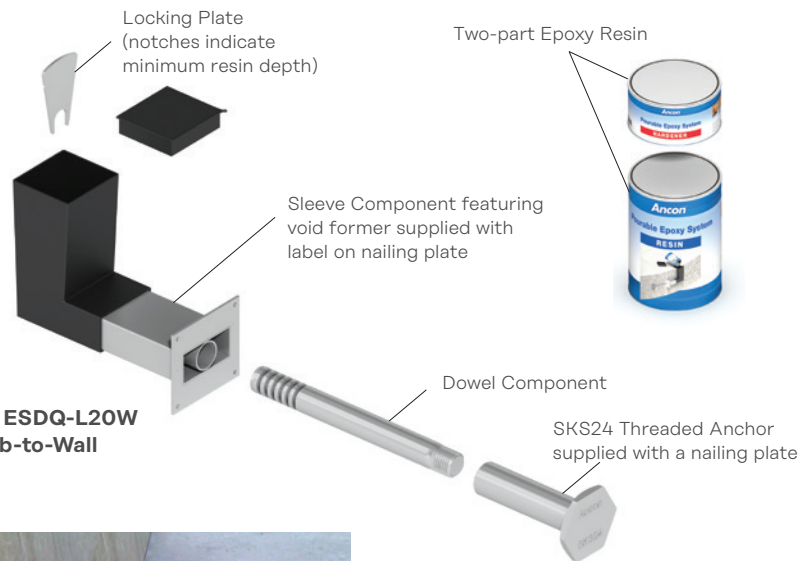

Ancon ESDQ-L20W for Slab-to-Wall



Void formers shown at Slab-to-Wall joint



Slab-to-Wall Application

# Ancon Lockable Dowels and Locking Pins

## Range of Locking Pins

Ancon Locking Pin allows initial shrinkage of the concrete to take place and then, after a pre-determined time period (generally 3-4 weeks), is locked in position with a mechanical plate and a controlled amount of Ancon high strength, cementitious, non-shrink grout. The range comprises the ALP19 for slab-to-slab applications and the ALP19W for slab-to-wall applications.

## Slab-to-Slab Locking Pin

### ALP19

The pin component is manufactured from 500MPa coil bar which comprises a constant rolled thread. One end of the pin features a hot forged head which increases its resistance to tensile forces; the size of this head complies with the AUS/NZ standard for headed reinforcement. The other end of the pin features a notch to accept the Ancon locking plate.

When installed in the heavy duty injection moulded sleeve, the pin component is suspended in a tube; a locating bush and pinch points cradle the bar to ensure even distribution of the grout. The sleeve allows lateral and some rotational movement of the pin, in addition to longitudinal movement, prior to locking. The sleeve is ribbed on the outside for increased bond with the concrete and features indentations on the inside to maximise grout bond. The sleeve features the standard Ancon void former. A blue lid allows easy identification on site, differentiating it from a Lockable Dowel in a cast slab.

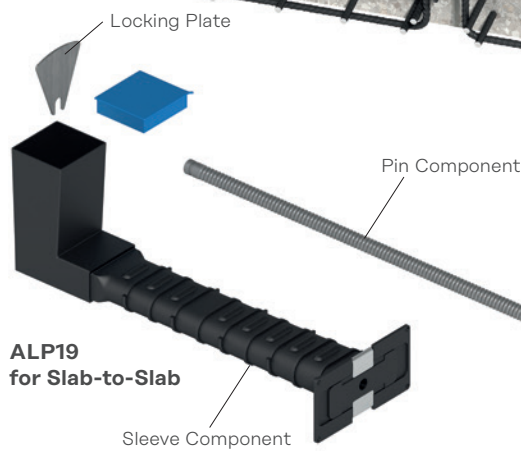
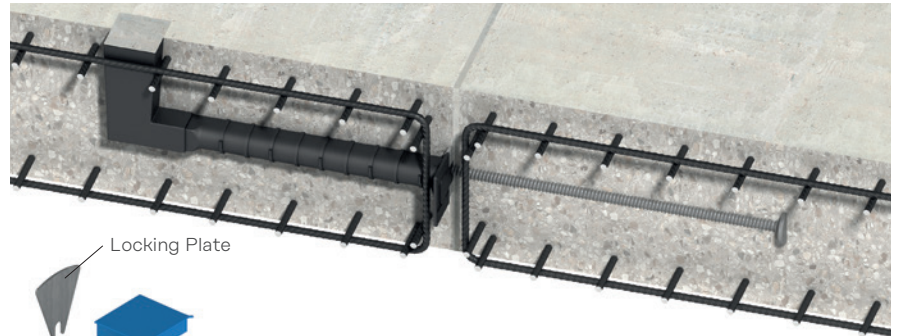

ALP19 for Slab-to-Slab

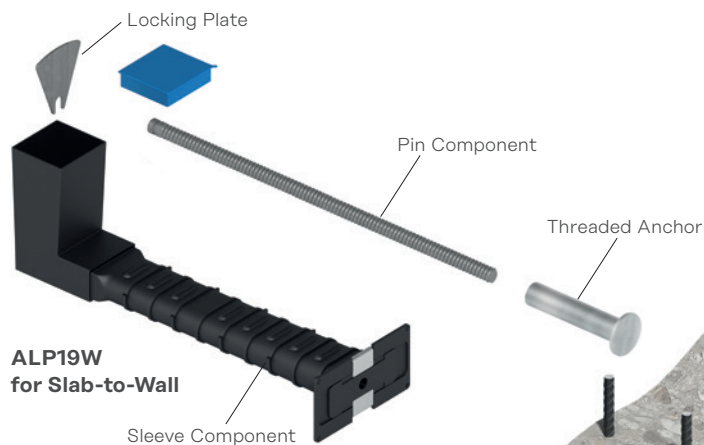

ALP19W for Slab-to-Wall

## Slab-to-Wall Locking Pin

### ALP19W

For walls, the pin component is manufactured from 500MPa coil bar like in the slab-to-slab system but is shorter in length. One end of the pin screws directly into a threaded anchor (product ref. ALP19TA) that is cast into the face of the concrete wall and the other end features a notch to accept the proprietary Locking Plate. The sleeve component is the same as used in the standard slab-to-slab ALP system.

### High Strength Grout

In combination with the mechanical locking plate, the Pin is locked with Ancon high strength, cementitious, non-shrink grout. We recommend the grout is mixed to a flowable consistency which, at a normal curing temperature (20°C), achieves a compressive strength of 20MPa in 24 hours and 75MPa in 28 days. Users should refer to storage and mixing instructions supplied with the product.

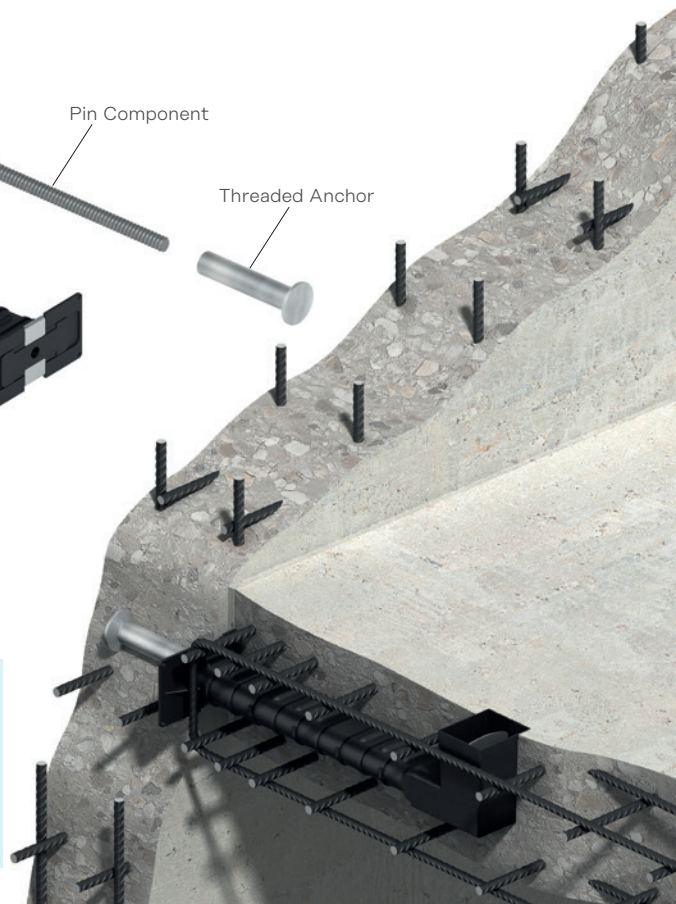

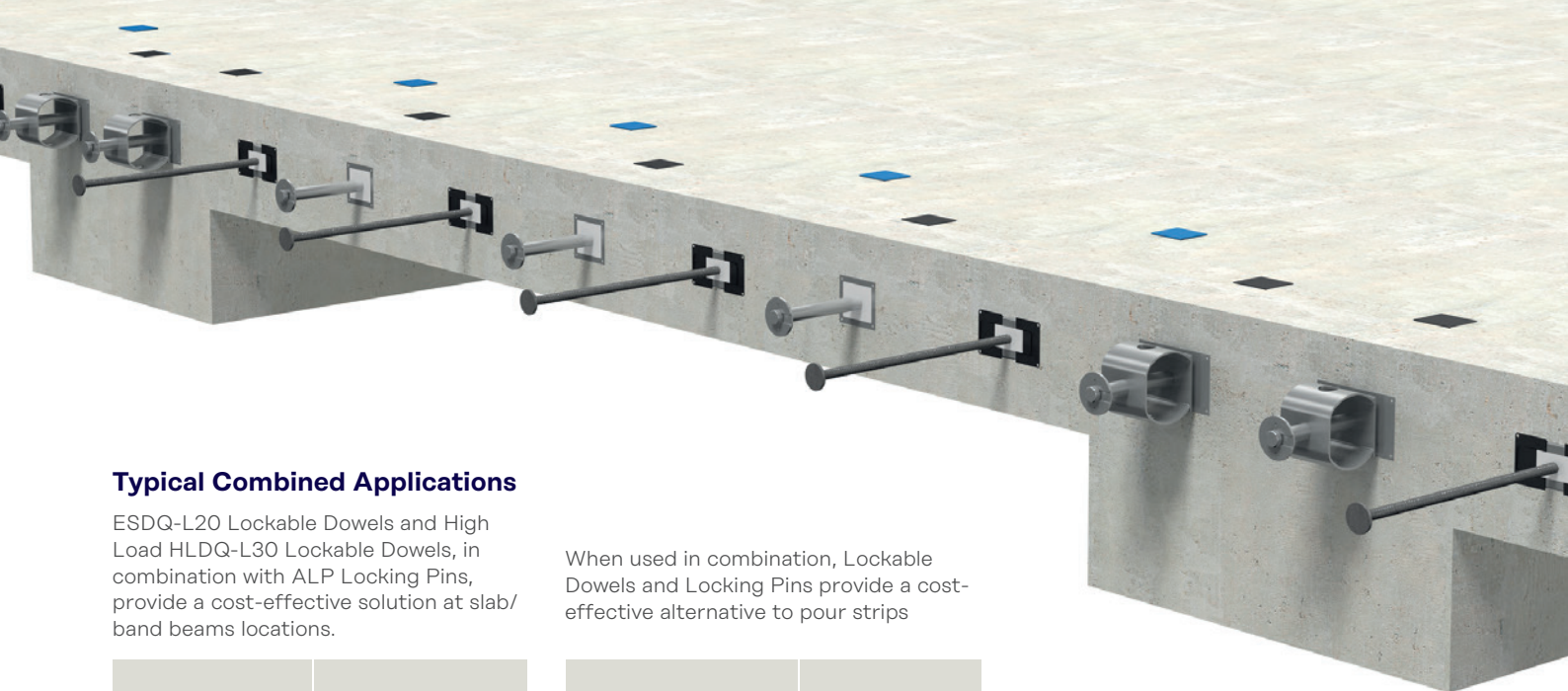

### Typical Combined Applications

ESDQ-L20 Lockable Dowels and High Load HLDQ-L30 Lockable Dowels, in combination with ALP Locking Pins, provide a cost-effective solution at slab/band beams locations.

When used in combination, Lockable Dowels and Locking Pins provide a cost-effective alternative to pour strips

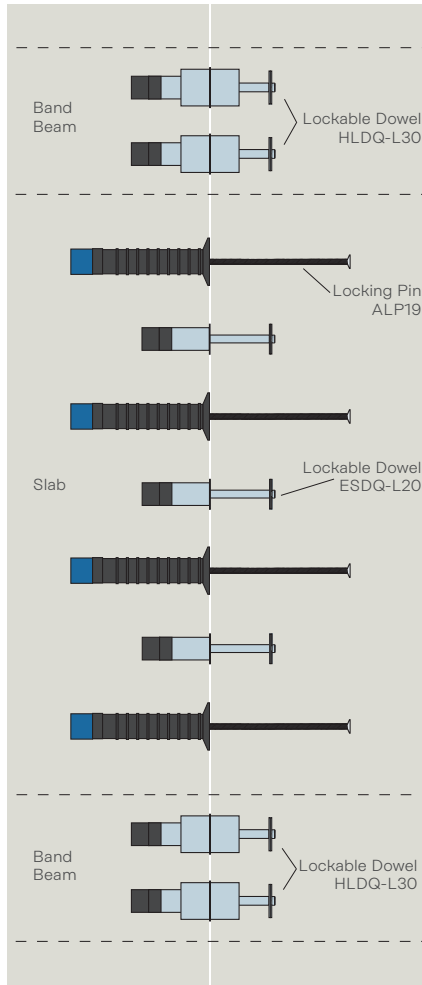

Slab and band beam typical configuration

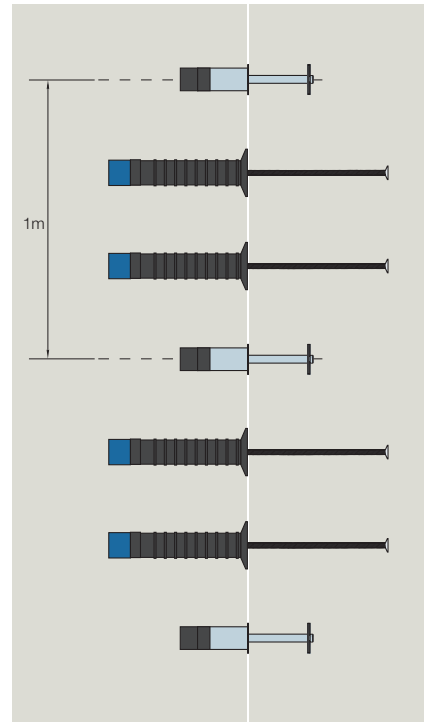

Typical temporary movement joint configuration

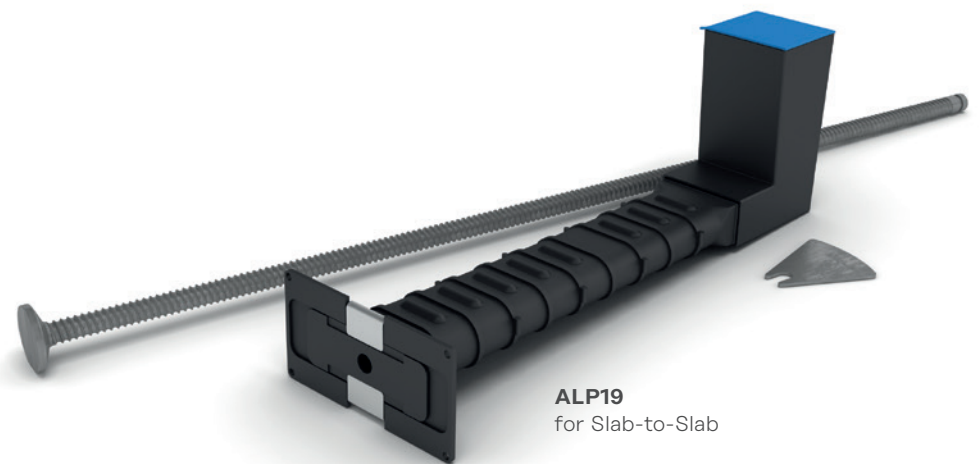
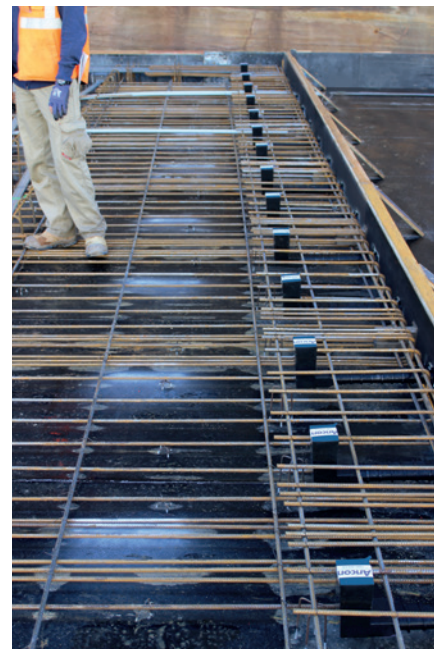

**ALP19**  
for Slab-to-Slab

# Ancon Lockable Dowels and Locking Pins

## Ancon Lockable Dowel Design Strengths

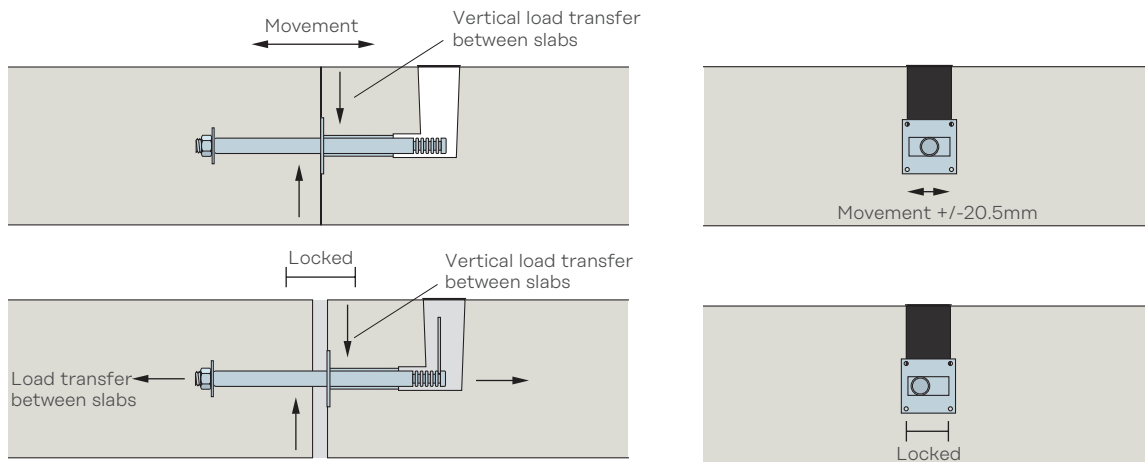

### Ancon ESDQ-L20 Lockable Dowels (slab-to-slab)

Slab Thickness (mm)	Tension along line of dowel (kN)	Vertical Design Resistance (kN) for Various Design Joint Widths (mm) in 32MPa Concrete							
		5	10	15	20	25	30	35	40
160	45	12.0	12.0	12.0	12.0	12.0	12.0	12.0	12.0
180	65	25.0	25.0	25.0	25.0	25.0	25.0	25.0	25.0
200	80	40.0	40.0	40.0	40.0	40.0	40.0	40.0	40.0
220	100	53.6	53.6	53.6	53.6	53.6	53.6	53.6	52.7
240	100	62.2	62.2	62.2	62.2	60.6	57.8	55.2	52.7
260 and above	100	71.4	69.9	66.6	63.5	60.6	57.8	55.2	52.7

### Ancon ESDQ-L20W Lockable Dowels (slab-to-wall)

Slab Thickness (mm)	Tension along line of dowel (kN)	Vertical Design Resistance (kN) for Various Design Joint Widths (mm) in 32MPa Concrete							
		5	10	15	20	25	30	35	40
160	45	12.0	12.0	12.0	12.0	12.0	12.0	12.0	12.0
180	65	25.0	25.0	25.0	25.0	25.0	25.0	25.0	25.0
200	80	40.0	40.0	40.0	40.0	40.0	40.0	40.0	40.0
220	80	53.6	53.6	53.6	53.6	53.6	53.6	53.6	52.7
240	80	62.2	62.2	62.2	62.2	60.6	57.8	55.2	52.7
260 and above	80	71.4	69.9	66.6	63.5	60.6	57.8	55.2	52.7

### Ancon HLDQ-L30 Lockable Dowels (slab-to-slab)

Slab Thickness (mm)	Tension along line of dowel (kN)	Vertical Design Resistance (kN) for Various Design Joint Widths (mm) in 32MPa Concrete							
		5	10	15	20	25	30	35	40
240 and above	100	136.0	136.0	136.0	136.0	136.0	136.0	136.0	121.9

#### ESDQ-L20 Example

Slab thickness = 240mm  
 Joint width = 20mm  
 Concrete strength = 32MPa  
 Characteristic permanent action (dead load) = 45kN/m  $\gamma_G = 1.2$   
 Characteristic variable action (imposed load) = 50kN/m  $\gamma_Q = 1.5$   
 Design load =  $1.2 \times 45 + 1.5 \times 50 = 129\text{kN/m}$   
 Vertical design resistance = 62.2kN (240mm slab 20mm joint)  
 Therefore centres for vertical load =  $62.2 / 129 = 0.482\text{m}$  use 450mm centres

Each dowel will in addition provide a design resistance across the joint of 100kN (for slab to wall this is 80kN), therefore the total design resistance in the direction of the dowel =  $100 / 0.45 = 222\text{kN}$  (for slab to wall  $80 / 0.45 = 177\text{kN}$ ).

If this is insufficient, the dowel centres can be reduced to a minimum of  $1.5 \times$  slab thickness to increase the design capacity across the joint, in this example it would increase to  $100 / 0.36 = 277\text{kN}$  (for slab to wall  $80 / 0.36 = 222\text{kN}$ ).

#### Joint Filler / Fire Protection

We can provide information on a suitable joint filler and also recommend fire resistant material which could be used as part of an overall fire protection system.

#### Reinforcement Details

Local reinforcement is required around each Ancon Lockable Dowel to guarantee that the forces are transferred between the connectors and the concrete. See page 12 for full details.



## Edge Distance and Spacings

For connectors working at or near their maximum capacity, the minimum spacing should be 1.5 times the slab thickness. Where the design load of the connector could be used in a thinner slab, a spacing of 1.5 times the thinner slab thickness can be used. The minimum end distance is always 0.5 times the spacing.

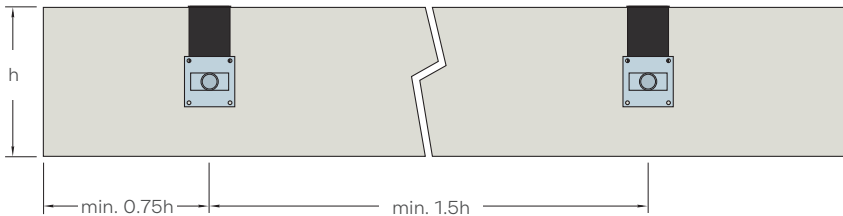

ESDQ-L20 Minimum Edge Distance and Spacings

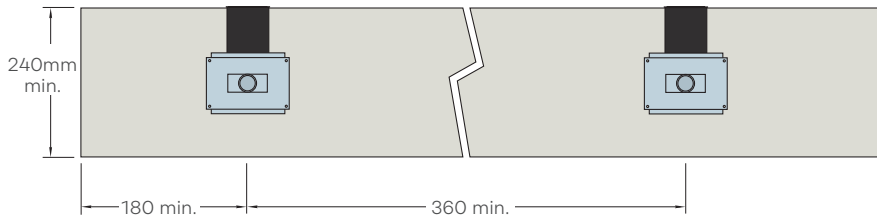

HLDQ-L30 Minimum Edge Distance and Spacings

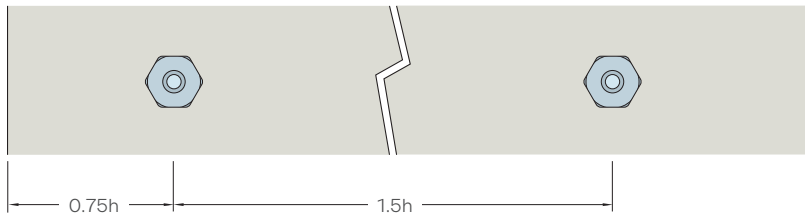

ESDQ-L20W Minimum Edge Distance and Spacings.  $h$  = depth of adjoining slab

### ESDQ-L20 Example

Slab thickness	= 300mm
Maximum width of joint	= 20mm
Concrete strength	= 32MPa
Design resistance/connector (based on slabs 260mm and above)	= 63.5kN
Spacing for max. load	$300 \times 1.5 = 450\text{mm}$
End distance for max. load	$450 \times 0.5 = 225\text{mm}$
Design resistance/metre	$= 63.5 / 0.45 = 141.1\text{kN/m}$

As an ESDQ-L20 can be used in a 220mm slab for a design resistance per connector of up to 53.6kN, the spacing can be based on a 220mm slab. Therefore:

Reduced spacing	$220 \times 1.5 = 330\text{mm}$
Reduced end distance	$330 \times 0.5 = 165\text{mm}$
Design resistance/metre	$53.6 / 0.33 = 162.4\text{kN/m}$

# Ancon Lockable Dowels and Locking Pins

## Reinforcement Details

Local reinforcement is required around each Ancon Lockable Dowel to guarantee that the forces are transferred between the connectors and the concrete. Correct detailing in accordance with appropriate design codes and the recommendations provided here will ensure the dowels attain their full capacity. The tables show the main reinforcement required, together with details of reinforcement above and below the connectors. **Although only the sleeve components are illustrated, the same reinforcement is required around the dowel component.**

### Ancon ESDQ-L20

Slab Depth (mm)	U-bars		Longitudinal bars	
	Number and size	Spacing	Number and size	Spacing
160	1 N10	The first U-bars should be placed immediately adjacent to the connector. The subsequent U-bars should be placed as close as possible allowing the appropriate minimum clear distance – nominally 20mm.	1 N10	The longitudinal bars should be placed as close to the slab edge as possible in the bend of the U-bar.
180	1 N12		1 N12	
200	2 N12		1 N12	
220	2 N12		1 N12	
240	3 N12		1 N12	
260	3 N12		1 N12	

### Ancon HLDQ-L30

U-bars	Dowel side		Sleeve side		Longitudinal bars	Spacing f <sub>1</sub> (mm)
	e <sub>1</sub> (mm)	e <sub>2</sub> (mm)	e <sub>1</sub> (mm)	e <sub>2</sub> (mm)		
3 N12	70	40	95	40	2 N12	(100) 70*

\* For minimum slab thickness, the longitudinal bars will be further from the slab edge due to limited space (f<sub>1</sub> = 100mm). For thicker slabs, the longitudinal bars should be within the bend of the U-bar (f<sub>1</sub> = 70mm).

### Ancon ESDQ-L20W Wall/Anchor Side

Wall thickness (mm)	Slab thickness (mm)	Vertical links	Spacing		Horizontal straight bars	Spacing f <sub>1</sub> (mm)
			e <sub>1</sub> (mm)	e <sub>2</sub> (mm)		
>230	160	1 N10	30	35	1 N10	30
	180	1 N12			1 N12	40
	200	2 N12			1 N12	50
≥280	220	2 N12			1 N12	60
	240	3 N12			1 N12	70
	260	3 N12			1 N12	80

**Note:** Rebar for sleeve side is as ESDQ-L20 sleeve side. Provide a minimum of two vertical bars to rear face of wall to engage with link.

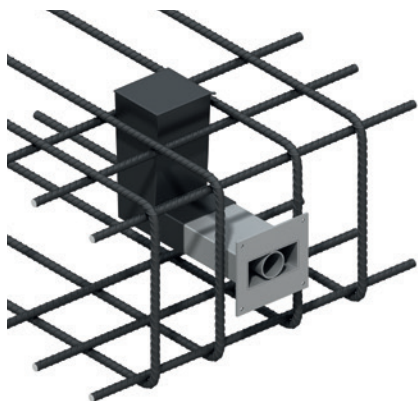

Ancon ESDQ-L20

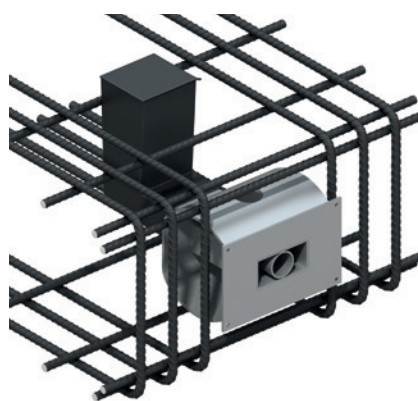

Ancon HLDQ-L30



SKS24 Threaded Anchor, part of Ancon ESDQ-L20W

**Ancon ESDQ-L20**

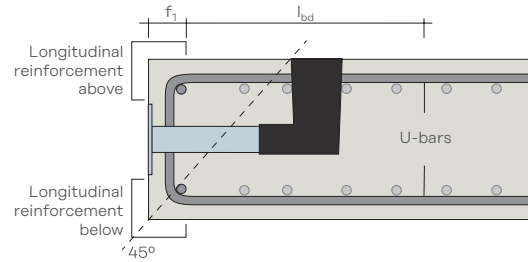

\* appropriate clear spacing between U-bars nom. dim. 20mm  
 \*\* first U-bars placed immediately adjacent to connector (nom. dim. 0mm)

**Ancon HLDQ-L30**

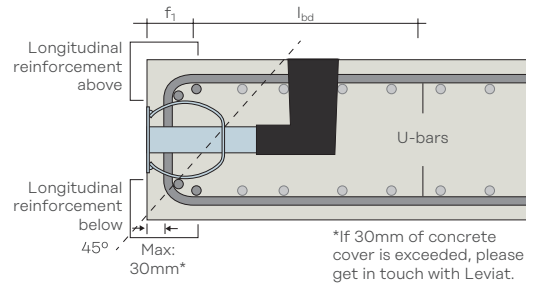
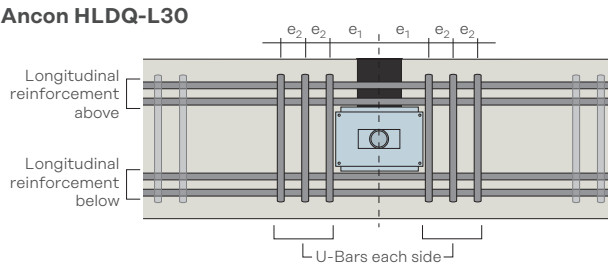

**SKS24 Threaded Anchor, part of Ancon ESDQ-L20W**

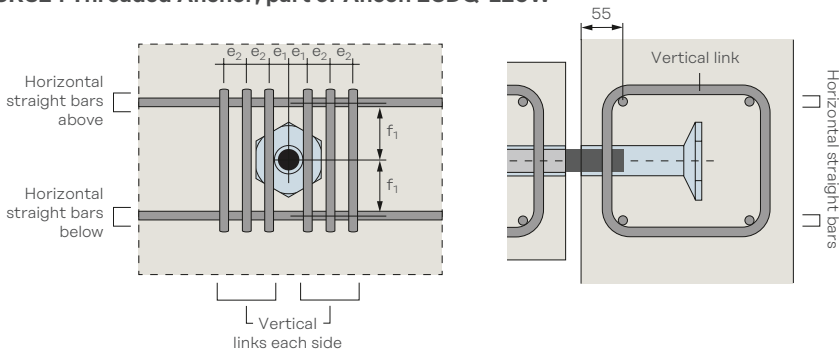

**ALP19**

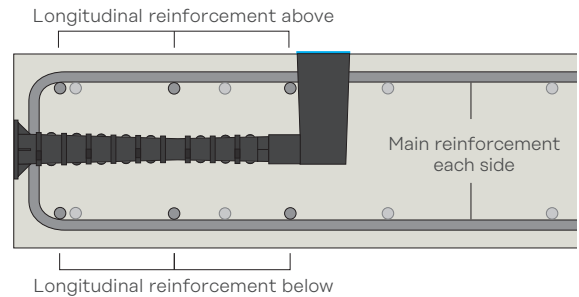
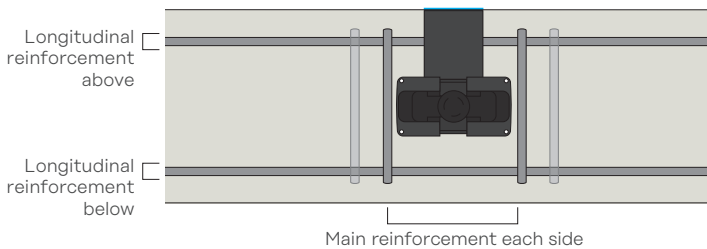

**Threaded Anchor**

Reinforcement around the Ancon Threaded Anchor should be a minimum diameter of 12mm, installed at maximum 200mm vertical and horizontal centres.

# Ancon Lockable Dowels and Locking Pins

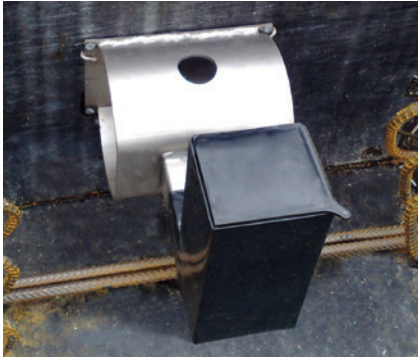

HLDQ-L30 Sleeve Component



## Dimensions

### Ancon ESDQ-L20 Components Dowel Component

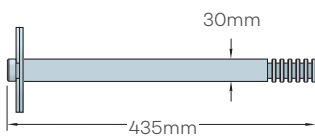

### Sleeve Component

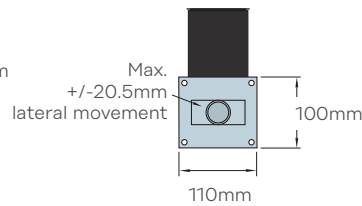
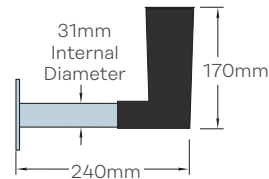

### Ancon HLDQ-L30 Components Dowel Component

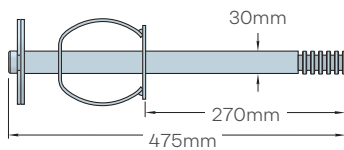
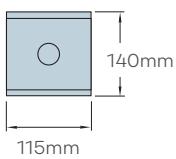

### Sleeve Component

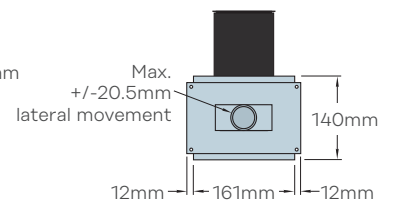
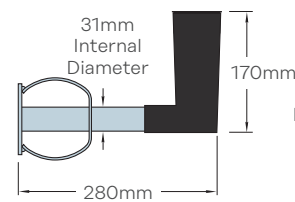

### Ancon ESDQ-L20W Components SKS24 Threaded Anchor

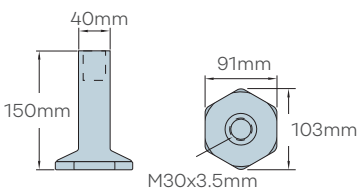

### Dowel Component

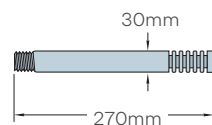

### Sleeve Component

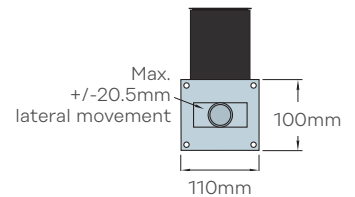
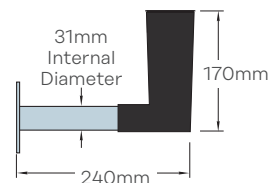

## Locking Pin Performance & Dimensions

Locking Pins are ideal for use in applications where tension loads are high but there is little or no shear load or where the shear load is accommodated elsewhere for example either by a support corbel, double column or an alternate Ancon shear load connector.

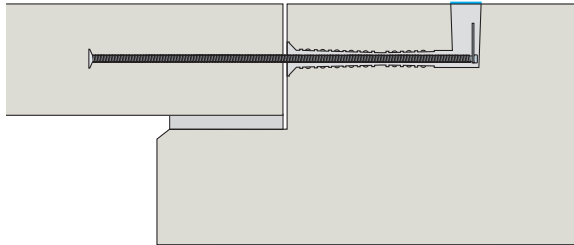

The Ancon Locking Pin offers many advantages over the site-assembled arrangement of carbon steel reinforcing bar, PT ducting, vent tubes and a non-specific grout, which is sometimes used by concrete contractors. Locking Pins are a reliable engineered solution that offers ease of installation and proven performance.

### Independent Testing

Tested at the Centre for Advanced Structural Engineering at the University of Sydney.

The 19mm diameter pin component exceeds the tensile resistance of a standard 16mm reinforcing bar. It offers the added benefit of forming an independently verified, easy-to-install Ancon system.

Product Ref.	Design* Resistance
ALP19	80kN
ALP19W	80kN

\*min.180mm slab, min. 32MPa concrete

### Dimensions

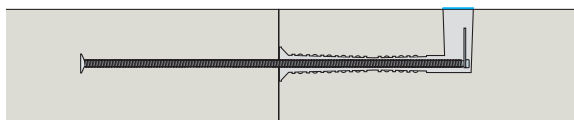

#### Pin Component

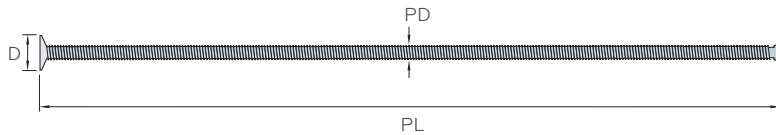

#### Sleeve Component

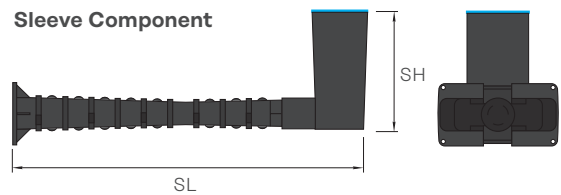

Product Ref.	Stud Head Diameter D	External Pin Diameter PD	Net Cross Sectional Area of pin	Pin Length PL	Sleeve Length SL	Sleeve Height SH	Nailplate	Pin Lateral Movement
ALP19	50mm	19mm	201mm <sup>2</sup>	1000mm	510mm	170mm	180 x 80mm	+/-20mm

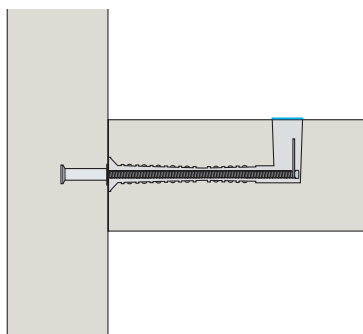

#### Threaded Anchor ALP19TA

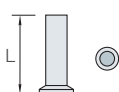

#### Pin Component

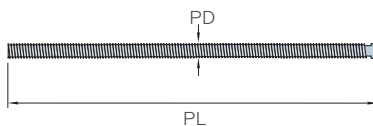

#### Sleeve Component

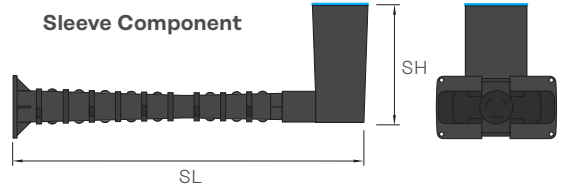

Product Ref.	Anchor Length L	External Pin Diameter PD	Net Cross Sectional Area of pin	Pin Length PL	Sleeve Length SL	Sleeve Height SH	Nailplate	Pin Lateral Movement
ALP19W	150mm	19mm	215mm <sup>2</sup>	543mm	506mm	170mm	180 x 80mm	+/-20mm

# Ancon Lockable Dowels and Locking Pins

## Installation: Slab-to-Slab

Although installation is shown for the ESDQ-L20, the procedure is the same for the HLDQ-L30.

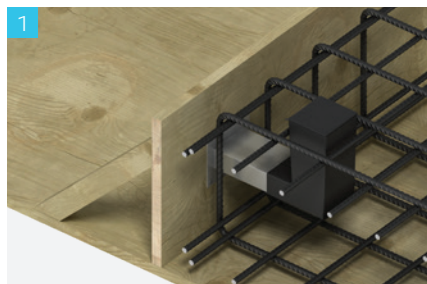

Nail the sleeve to the formwork either central in the slab or for slab depths over 300mm so the top of the void former is level with the top of the slab. Do not remove the label over the nailing plate as this prevents ingress of concrete into the sleeve. Fix the local reinforcement, as specified on engineer's drawings.



Pour the concrete, and when of sufficient strength, strike the formwork. Puncture the label to reveal the cylindrical sleeve only and insert the dowel until it is approximately 20mm from the back of the void former.



Fix the local reinforcement around the dowel component and pour the concrete.

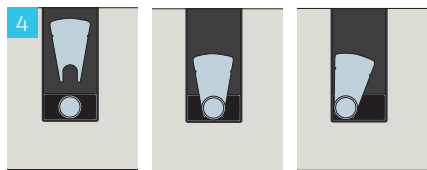

After a predetermined time period (generally 3-4 weeks), when movement between the slabs has stabilised and the joint between the slabs has been filled, the dowel is ready to be locked.

Fit the Locking Plate on a groove in the centre of the void former. The fan-shaped Locking Plate allows the dowel to be locked in any position.



Mix the two-part epoxy resin and pour into the void former. It is essential the resin flows along the stainless steel box section towards the joint and reaches the notches on the locking plate, which indicate minimum resin depth. Joint must be filled before resin is installed.



After 24 hours the void former can be filled with cementitious material, level with the top of the slab, to complete the installation.

The locked dowel continues to transfer vertical load between the slabs, but movement can no longer take place.

## Slab-to-Wall

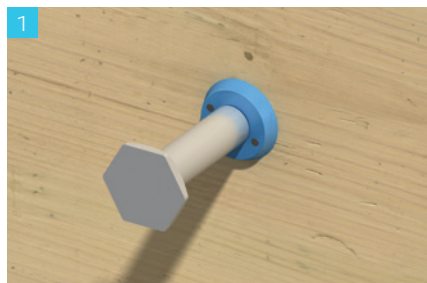

Nail the threaded anchor to the formwork so the dowel will be central in the adjoining slab or within 150mm of the top of slabs over 300mm. Fix the local reinforcement as specified on engineer's drawings and cast the concrete.



When concrete reaches sufficient strength, strike the formwork and remove nailing plate. Screw the dowel into the anchor.

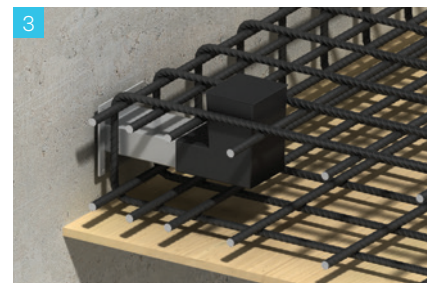

Puncture the label of the sleeve to reveal the cylindrical sleeve only. Push the sleeve over the dowel until it is flush with the concrete. Tie sleeve to reinforcement and pour concrete.

See Steps 4 to 6 above to complete installation.

**Notes:** Where deep concrete pours are proposed, the installation will require further consideration. More robust fixing of the sleeve and dowel components will be necessary, to avoid displacement during casting of the concrete.



## Installation: Locking Pin

Locking Pins provide many advantages over a site-assembled arrangement of carbon steel reinforcing bar, PT ducting, vent tubes and a non-specific grout, including ease of installation and proven performance.

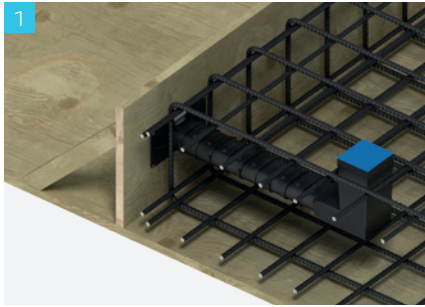

Nail the sleeve to the formwork either central in the slab or for slab depths over 300mm so the top of the void former is level with the top of the slab. Do not remove the label over the nailing plate as this prevents ingress of concrete into the sleeve. Fix the local reinforcement.



Pour the concrete, and when of sufficient strength, strike the formwork. Puncture the label to reveal the cylindrical sleeve only and insert the pin until it is approximately 10mm from the back of the void former.



Fix the local reinforcement. Tie the pin to the local reinforcement for additional support and pour the concrete.

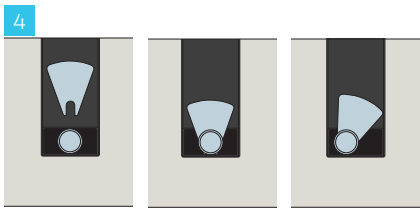

After a predetermined time period (generally 90-120 days) when movement between the slabs has stabilised and the joint between the slabs has been filled, the pin is ready to be locked. Fit the Locking Plate on the groove at the end of the pin in the void former. The fan-shaped Locking Plate allows the pin to be locked in any position.



Mix the grout using a mechanical mixer (refer to separate installation instructions on grout packaging) and pour into the void former, ensuring it flows along the box section towards the joint, until level with the top of the slab. Joint must be filled before grout is installed.



After 24 hours, check the void former is fully filled level with the top of the slab, top up with more of the cementitious grout material if required, to complete the installation.

## Slab-to-Wall



Nail the Anchor to the formwork so the pin will be central in the adjoining slab or within 150mm of the top of slabs over 300mm. Fix the local reinforcement as specified on engineer's drawings and cast the concrete.



When concrete reaches sufficient strength, strike the formwork and remove nailing plate. Screw the pin into the anchor.

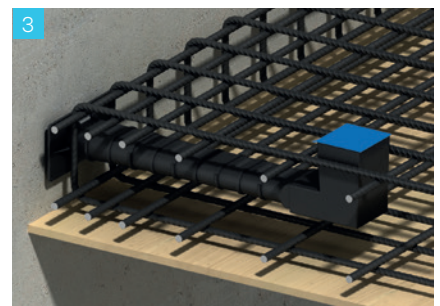

Puncture the label of the sleeve to reveal the cylindrical sleeve only. Push the sleeve over the pin until it is flush with the concrete. Tie sleeve to reinforcement and pour concrete.

See Steps 4 to 6 above to complete installation.

# Ancon Lockable Dowels and Locking Pins

## Project References



5,000 Lockable dowels were installed on the Royal Children's Hospital, Melbourne, VIC



2,500 Lockable dowels were installed on the Supreme & District Court, Brisbane, QLD



500 Lockable dowels were installed on the Emergency Care Centre in Aberdeen, UK

## Other Ancon Products

### DSD/Q Shear Load Connectors

Ancon DSD and DSDQ double-dowel connectors are used to transfer shear across movement joints in suspended concrete slabs. They are more effective at transferring load and allowing movement than standard single dowels and can be used to eliminate double columns at structural movement joints in buildings. The Q version features a rectangular box section to allow lateral and some rotational movement.

### Plate Dowel Systems

Ancon MultiJoint is a plate dowel system for use in ground bearing concrete floor slabs. It is an all-in-one solution to load transfer, concrete contraction, armoured edge protection and formwork. Individual plate dowels are also available.

### Punching Shear Reinforcement

Ancon Shearfix is used within a slab to provide additional reinforcement from punching shear around columns. The system consists of double-headed steel studs welded to flat rails and is designed to suit the load conditions and slab depth at each column using our free calculation software.

### Reinforcing Bar Couplers

The use of reinforcing bar couplers can provide significant advantages over lapped joints. Design and construction of the concrete can be simplified and the amount of reinforcement can be reduced. The Ancon range includes BT parallel-threaded and MBT mechanically-bolted couplers.

### Reinforcement Continuity Systems

Reinforcement Continuity Systems are an increasingly popular means of maintaining continuity of reinforcement at construction joints in concrete. The Ancon Keybox system eliminates the need to drill shuttering and can simplify formwork design, thereby accelerating the construction process. It is available in both standard units and special configurations. Ancon KSN Anchors eliminate the need for on-site bar straightening and are available as standard to accept 12mm, 16mm and 20mm diameter rebar. The system is also available with a re-useable rebate former.

### Stainless Steel Reinforcement

Leviat supplies stainless steel plain and ribbed bar in a variety of grades, including high proof strength material, direct from stock. Bar diameters range from 6mm to 50mm and can be cut to length, bent and threaded to suit any application. Stainless steel BT couplers are also available to suit bars from 12mm diameter.





# Leviat®

Innovative engineered products and construction solutions that allow the industry to build safer, stronger and faster.



# Contact Leviat worldwide

## Australia

Unit A, 1 Heinrich Close,  
Eastern Creek, Sydney, NSW 2766  
Tel: +61 - 2 8808 3100  
Email: [info.au@leviat.com](mailto:info.au@leviat.com)

## Austria

Leonard-Bernstein-Str. 10 Saturn  
Tower, 1220 Wien  
Tel: +43 - 1 - 259 6770  
Email: [info.at@leviat.com](mailto:info.at@leviat.com)

## Belgium

Industrielaan 2  
1740 Ternat  
Tel: +32 - 2 - 582 29 45  
Email: [info.be@leviat.com](mailto:info.be@leviat.com)

## China

Room 601 Tower D,  
Vantone Centre  
No. A6 Chao Yang Men Wai Street  
Chaoyang District  
Beijing P.R. China 100020  
Tel: +86 - 10 5907 3200  
Email: [info.cn@leviat.com](mailto:info.cn@leviat.com)

## Czech Republic

Business Center Šafránková  
Šafránková 1238/1  
155 00 Praha 5  
Tel: +420 - 311 - 690 060  
Email: [info.cz@leviat.com](mailto:info.cz@leviat.com)

## Finland

Vädursgatan 5  
412 50 Göteborg / Sweden  
Tel: +358 (0)10 6338781  
Email: [info.fi@leviat.com](mailto:info.fi@leviat.com)

## France

6, Rue de Cabanis  
FR 31240 L'Union  
Toulouse  
Tel: +33 - 5 - 34 25 54 82  
Email: [info.fr@leviat.com](mailto:info.fr@leviat.com)

## Germany

Liebigstrasse 14  
40764 Langenfeld  
Tel: +49 - 2173 - 970 - 0  
Email: [info.de@leviat.com](mailto:info.de@leviat.com)

## India

309, 3rd Floor  
Orion Business Park  
Ghodbunder Road  
Kapurbawdi, Thane West,  
Thane, Maharashtra 400607  
Tel: +91 - 22 2589 2032  
Email: [info.in@leviat.com](mailto:info.in@leviat.com)

## Italy

Via F.lli Bronzetti 28  
24124 Bergamo  
Tel: +39 - 035 - 0760711  
Email: [info.it@leviat.com](mailto:info.it@leviat.com)

## Malaysia

28 Jalan Anggerik Mokara 31/59  
Kota Kemuning,  
40460 Shah Alam Selangor  
Tel: +603 - 5122 4182  
Email: [info.my@leviat.com](mailto:info.my@leviat.com)

## Netherlands

Oostermaat 3  
7623 CS Borne  
Tel: +31 - 74 - 267 14 49  
Email: [info.nl@leviat.com](mailto:info.nl@leviat.com)

## New Zealand

PO Box 33232  
Barrington  
Christchurch 8244  
Tel: +64 - 3 376 5205  
Email: [info.nz@leviat.com](mailto:info.nz@leviat.com)

## Norway

Vestre Svanholmen 5  
4313 Sandnes  
Tel: +47 - 51 82 34 00  
Email: [info.no@leviat.com](mailto:info.no@leviat.com)

## Philippines

2933 Regus, Joy Nostalg,  
ADB Avenue, Ortigas Center  
Pasig City  
Tel: +63 - 2 7957 6381  
Email: [info.ph@leviat.com](mailto:info.ph@leviat.com)

## Poland

Ul. Obornicka 287  
60-691 Poznań  
Tel: +48 - 61 - 622 14 14  
Email: [info.pl@leviat.com](mailto:info.pl@leviat.com)

## Singapore

14 Benoi Crescent  
Singapore 629977  
Tel: +65 - 6266 6802  
Email: [info.sg@leviat.com](mailto:info.sg@leviat.com)

## Spain

Polígono Industrial Santa Ana  
c/ Ignacio Zuloaga, 20  
28522 Rivas-Vaciamadrid  
Tel: +34 - 91 632 18 40  
Email: [info.es@leviat.com](mailto:info.es@leviat.com)

## Sweden

Vädursgatan 5  
412 50 Göteborg  
Tel: +46 - 31 - 98 58 00  
Email: [info.se@leviat.com](mailto:info.se@leviat.com)

## Switzerland

Grenzstrasse 24  
3250 Lyss  
Tel: +41 (0)800 22 66 00  
Email: [info.ch@leviat.com](mailto:info.ch@leviat.com)

## United Arab Emirates

RA08 TB02, PO Box 17225  
JAFZA, Jebel Ali, Dubai  
Tel: +971 (0)4 883 4346  
Email: [info.ae@leviat.com](mailto:info.ae@leviat.com)

## United Kingdom

President Way,  
President Park,  
Sheffield S4 7UR  
Tel: +44 - 114 275 5224  
Email: [info.uk@leviat.com](mailto:info.uk@leviat.com)

## USA / Canada

6467 S Falkenburg Road  
Riverview, FL 33578  
Tel: (800) 423-9140  
Email: [info.us@leviat.us](mailto:info.us@leviat.us)

For countries not listed  
Email: [info@leviat.com](mailto:info@leviat.com)

## Notes regarding this document

© Protected by copyright. The information in this publication is based on state-of-the-art technology at the time of publication. In every case, project working details should be entrusted to appropriately qualified and experienced persons. Leviat shall not accept liability for the accuracy of the information in this document or for any printing errors. We reserve the right to make technical and design changes at any time. With a policy of continuous product development, Leviat reserves the right to modify product design and specification at any time.

# Contact Leviat locally

For more information on the products featured here, please contact Leviat:

**For more information on the following products, please contact:**

**Masonry, Structural and Precast Concrete products:**

1300 304 320  
info.ancon.au@leviat.com  
Ancon.com.au

**Concrete Floor Jointing products:**

1800 335 215  
info.connolly.au@leviat.com  
Connollykeyjoint.com  
info.isedio.au@leviat.com  
Isedio.com.au

**Remedial Masonry products:**

1300 667 071  
info.helifix.au@leviat.com  
Helifix.com.au

**General Enquiries**

T: 1300 304 320  
Leviat.com

**Sales Offices and Production**

**New South Wales, Sydney**

Unit A, 1 Heinrich Close,  
Eastern Creek | Sydney  
NSW 2766

**Queensland**

17 Goodman Place  
Murarrie | Brisbane  
QLD 4172

**New South Wales, Casino**

10 Irving Drive  
Casino  
NSW 2470

**South Australia**

Unit 2/35-37 Maxwell Road  
Laverton North | Adelaide  
SA 5095

**Victoria**

9/63-69 Pipe Road  
Laverton North | Melbourne  
VIC 3026

**Western Australia**

18 Tennant Street  
Welshpool | Perth  
WA 6106

# Leviat®