

**REPORT OF TESTS ON ANCON HRT4 2.5mm DIAMETER,  
200mm LONG STAINLESS STEEL WIRE WALL TIES**

**Summary Report No. 0160.**

**Test Reference: SW114.01**

**Issue Date: 22/08/2002**

**Product**

HRT4 2.5mm diameter, 200mm long stainless steel wire wall ties were supplied by Ancon Building products to be tested in tension and compression over a nominal cavity width of 50mm in accordance with AS/NZS 2699.1:2000 Built in components for masonry construction. Part 1 Wall Ties.

**Client**



**Ancon Building Products**  
114 Kurrajong Avenue  
Mount Druitt  
Sydney  
NSW 2770

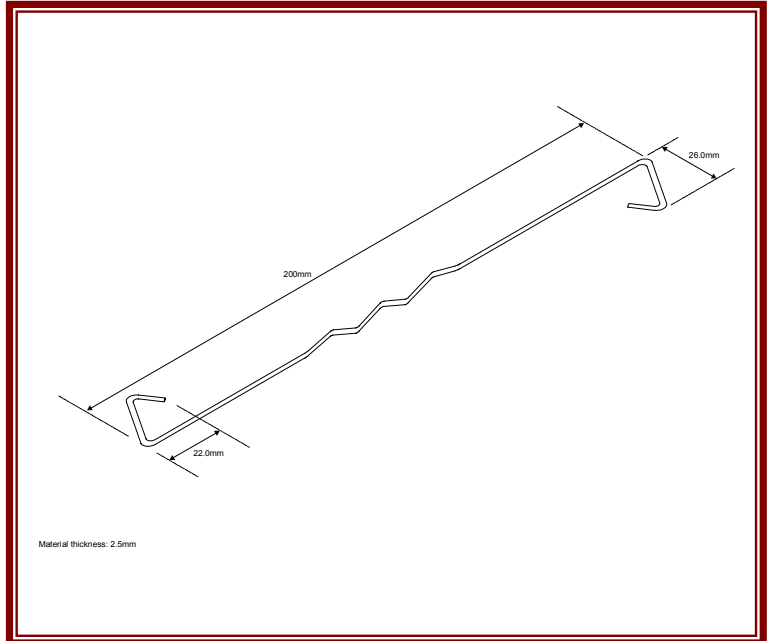

**Test Results**

*In both tension and compression, sets of 20 ties were tested. In both cases 2 results were dismissed as being abnormal test results when upper and lower exclusion limits were calculated in accordance with Appendix B Clause B10. Hence all characteristic values have been calculated using the remaining results of sets of 18.*

**Summary of Characteristic Values of Ancon HRT4 Ties Tested at 50mm cavity in Designation (iv) mortar with a 10mm Horizontal and 5mm Vertical Applied Displacement**

Test	Characteristic Load at 1.5mm Deflection (N)	*AS/NZ 2699.1:200 Recommended Load at 1.5mm Deflection (N)
Tension	856	400
Compression	587	480

**Note:**

The ties have been compared against the AS/NZ requirements for a medium duty tie

**Assessment**

The Ancon HRT4 2.5mm diameter, 200mm long wire wall tie met the AS/NZ 2699.1:2000 requirements for a Type A medium duty wall tie when tested at a cavity width of 50mm.

Full test results are reported in CERAM Building Technology Test Report No. SW114.01

**Authorised by:**

**Joanne Booth**  
(Manager, Structures Group)

This report is issued in accordance with the conditions of Business of CERAM Research and relates only to the sample(s) tested. No responsibility is taken for the accuracy of the sampling unless this is done under our own supervision. This report shall not be reproduced in part without the written approval of CERAM Research, nor used in any way as to lead to misrepresentation of the results or their implications.