

CALCULATION METHOD

The design of Shearfix follows the specifications set out in the Clause 9.2 of AS 3600: 2009, but the major part of the design is based on the research presented by F K Lim and B V Rangan from the School of Engineering at Curtin University of Technology in Perth.

The design calculations check the shear stresses imposed on the critical shear perimeter surrounding the column, with Shearfix stud reinforcement provided as required.

Design Actions

When checking the shear capacity of the slab, the design shear force V^* and design transfer moment from the slab into the support M_v^* must be taken into account.

In the Shearfix Design Program, these values must be calculated and inputted into the program.

Critical Shear Perimeter

The critical shear perimeter “u” is the boundary of the effective area of a support or concentrated loads located at a distance of $d/2$, (d = effective depth of the slab).

For rectangular columns –

$$u = 2(x + d/2 + d/2) + 2(y + d/2 + d/2)$$

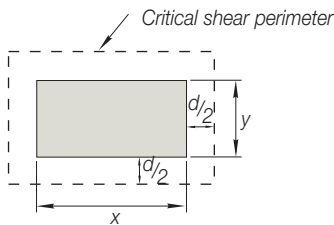

Where there are critical openings within $2.5 b_0$ from the critical perimeter, the projected width of the opening will be ineffective and will reduce the length of the critical perimeter.

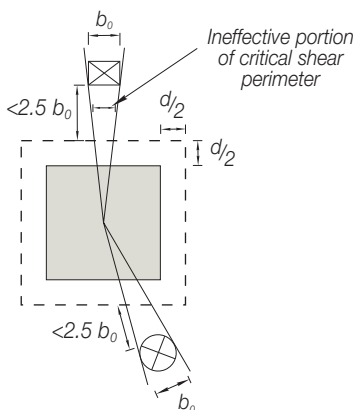

Calculation of Shear Stress

The shear capacity of the slab is determined in accordance to Clause 9.2.3 for the case where there are no transfer moments (M^* is zero), or Clause 9.2.4 for the case where there are transfer moments (M^* is not zero).

For the case where M^* is zero –

$$V_{uo} = ud(f_{cv} + 0.3\sigma_{cp})$$

Where –

V_{uo} = shear capacity of the slab

σ_{cp} = average pre-stress in concrete

F_{cv} = concrete shear strength, where –

$$f_{cv} = 0.17(1 + 2/\beta_h)\sqrt{f_c} \leq 0.34\sqrt{f_c}$$

β_h is the ratio of the effective loaded area = X/Y ($X \geq Y$)

For the case where M^* is not zero –

$$V_u = \frac{V_{uo}}{1 + (uM_v^*/8V^*ad)}$$

Where “a” is the dimension of the critical shear perimeter parallel in the direction of M_v^*

If $V^* > \phi Vu$ or ϕVu_0 , then Shearfix studs are required.

To determine the shear capacity of the slab with Shearfix studs for the slab strip, the following equation from Lim and Rangan is used –

$$V_u = V_{uo}(1 + k_s)$$

OR

$$V_u = \frac{V_{uo}}{\frac{1}{k_s} + \frac{uM_v^*}{8V^*ad}}$$

(the lesser result of the two equations)

where –

$$k_s = \frac{1}{V_{uo}} A_{vs} f_{vy} \frac{d}{s} \frac{u}{b}$$

A_{vs} = cross sectional area of a row of studs in the slab strip

F_{vy} = Yield strength of the stud (500 MPa)

s = spacing of the studs

b = width of the critical shear perimeter perpendicular to the direction M_v^*

For the torsion strip, the following equations are used –

$$V_u = V_{uo}(1 + k_s)$$

OR

$$V_{ut} = \frac{V_{uo}}{1 + k_t + \frac{uM_v^*}{8V^*ad}}$$

(the lesser result of the two equations)

where –

$$k_t = \frac{1}{V_{uo}} A_{vt} f_{vy} \frac{d}{s} \frac{u}{a}$$

A_{vt} = cross sectional area of a row of studs in the torsion strip

a = width of the critical shear perimeter parallel to the direction M_v^* (the width of the torsion strip)

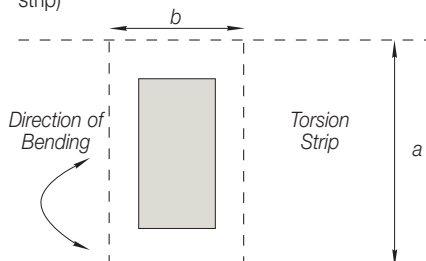

Minimum cross sectional area of stud reinforcement –

$$A_{vs} \geq \frac{0.35bs}{f_{vy}}$$

$$A_{vt} \geq \frac{0.35as}{f_{vy}}$$

When using the Shearfix Design Program, the program automatically determines the diameter, spacing and number of studs required.

Alternatively the user can specify the diameter, spacing and number of studs and check against the shear capacity of the slab.

Detailing

When using the Shearfix Design Program, the program automatically arranges the stud rails around the column.

When arranging Shearfix studs around columns, the following limits should be implemented –

- The position of the first stud from the column face is 0.5d (d = effective depth of slab)
- The maximum stud spacing is 500mm or 0.75D or 0.7(D – Top Cover – Bottom Cover – 5mm), whichever is less (D – overall depth of slab)
- The minimum spacing for 12mm studs is 45mm, and 55mm for 16mm studs
- The height of stud (h_s) is calculated as –
 $h_s = D - \text{Top cover} - \text{Bottom cover} - 5\text{mm}$
For 24mm Studs, the minimum stud height is 360mm
- The cross sectional area for the headed ends on each stud needs to be at least 10 times the cross sectional area of the stud diameter. (Clause 13.1.2.6, AS 3600: 2009). This ensures the stud is fully anchored to provide full transfer of forces through the stud.
- The maximum spacing between rails is 600mm or D, whichever is less
- The minimum spacing is 100mm
- The position of the last stud is located 2.5d from the column face
- The minimum slab thicknesses for each stud size is as follows –

Stud Size	Min Slab Thickness
12mm	150mm
16mm	175mm
20 – 24mm	200mm

For rectangular columns the areas of maximum stress will be at the corners of the column, because of this it is best to try and place rails at the end of the column sides.